

ÉCOLE DE TECHNOLOGIE SUPÉRIEURE  
UNIVERSITÉ DU QUÉBEC

MANUSCRIPT-BASED THESIS PRESENTED TO  
ÉCOLE DE TECHNOLOGIE SUPÉRIEURE

IN PARTIAL FULFILLMENT OF THE REQUIREMENTS FOR  
THE DEGREE OF DOCTOR OF PHILOSOPHY  
Ph. D.

BY  
Norma Angélica OROPEZA GARCIA

DEVELOPMENT OF AN ARTIFICIAL PHYTOREMEDIATION TECHNOLOGY  
FOR SOILS CONTAMINATED BY TOXIC METALS

MONTREAL, 22ND JULY 2013



Norma Angélica Oropeza García, 2013



This Creative Commons licence allows readers to download this work and share it with others as long as the author is credited. The content of this work can't be modified in any way or used commercially.

**BOARD OF EXAMINERS**  
**THIS THESIS HAS BEEN EVALUATED**  
**BY THE FOLLOWING BOARD OF EXAMINERS**

Mr. Robert Hausler, Thesis Supervisor  
Département de génie de la construction at École de technologie supérieure

Mr. Mathias Glaus, Thesis Co-supervisor  
Département de génie de la construction at École de technologie supérieure

Mr. Patrice Seers, Patrice Seers, President of the Board of Examiners  
Département de génie mécanique at École de technologie supérieure

Mr. Frédéric Monette, Member of the jury  
Département de génie de la construction at École de technologie supérieure

Mr. Serge Alex, Independent Evaluator  
Institut des Procédés Industriels at Collège de Maisonneuve

**THIS THESIS WAS PRESENTED AND DEFENDED**  
**IN THE PRESENCE OF A BOARD OF EXAMINERS AND PUBLIC**  
**MONTREAL, 24TH MAY 2013**  
**AT ÉCOLE DE TECHNOLOGIE SUPÉRIEURE**



## ACKNOWLEDGMENTS

I would like to express my sincere gratitude to my research director, Ph.D. Robert Hausler, for giving me the opportunity to work at STEPPE and for sharing some of his experience and expertise during the development of my doctorate. His support in all the situations that I have gone through during almost five years was always invaluable for me.

I would also like to express my appreciation to Ph.D. Mathias Glaus for his help and patience. Thanks for always being willing to listen to my questions and concerns raised during the development of this work.

I would like to thank Maria Cendan for her friendship and support during this time. Thanks for always being there!

I also would like to thank all the STEPPE companions with whom I shared these years, especially to Mirela, thank you for your friendship, enthusiasm and help in every way.

Thanks to my parents Angela and Rodolfo and my sisters Adriana, Amanda and Aurora for always being by my side despite the distance.

Special thanks to Ricardo, Valeria and Jimena for being the light of my way and for giving me the strength to keep going.

I express my gratitude for the financial support from PROMEP, the Mexico's Ministry of Education Program for the Professors Improvement.

I wish to thank for all the considerations and support received over this time from Quintana Roo's University.



# DÉVELOPPEMENT D'UNE TECHNOLOGIE ARTIFICIELLE DE PHYTOREMÉDIATION DE SOLS CONTAMINÉS PAR DES MÉTAUX TOXIQUES

Norma Angélica OROPEZA GARCIA

## RÉSUMÉ

À l'échelle mondiale, la contamination des sols et la pollution des eaux souterraines par les métaux toxiques (Pb, As, Cr, Ni, Zn, etc.) sont de plus en plus problématiques tant pour les écosystèmes que pour la santé humaine. Actuellement, la phytoextraction et la phytoaccumulation sont étudiées pour la décontamination des métaux, car elles offrent une option de traitement à faible coût. À partir d'une approche biomimétique, l'objectif général de ce travail est de proposer, au niveau conceptuel, une nouvelle technologie physico-chimique basée sur les mécanismes de transport de contaminants par les plantes.

Afin d'atteindre ces objectifs, un montage expérimental a été construit en laboratoire permettant de tester certains matériaux et les facteurs de fonctionnement. Les sept métaux étudiés et analysés par ICP-MS ont été l'aluminium, l'arsenic, le cadmium, le chrome, le nickel, le plomb et le zinc. Une fibre cellulosique (M1) et une autre de polyester-polyamide (M2) ont été utilisées comme moyens capillaires, car ils possèdent un diamètre similaire aux vaisseaux du xylème, système de transport des plantes vasculaires. Sur la base d'un gradient de pression négative de  $0.02 \text{ MPa}\cdot\text{m}^{-1}$ , rapporté pour le système vasculaire des plantes, les pressions négatives étudiées ont été  $0.011$ ,  $0.022$ ,  $0.045$ ,  $0.090$  et  $0.18 \text{ MPa}\cdot\text{m}^{-1}$ , tandis que les pH des solutions ont été de 4 et 8.

Les résultats montrent que le plus haut transport d'ions métalliques a été obtenu à pH 4, en l'ordre croissant :  $\text{Cr} < \text{Pb} = \text{Al} < \text{As} < \text{Ni} < \text{Zn} < \text{Cd}$  pour M1 et  $\text{Cr} < \text{Pb} = \text{Al} = \text{As} < \text{Ni} = \text{Zn} = \text{Cd}$  pour M2. Les différences dans le transport des ions entre M1 et M2, et exprimées en pourcentage de l'ion transporté, sont attribuées à la composition chimique des matériaux, en raison des quantités inégales de sites actifs sur la surface de chaque matériau, ainsi qu'à l'effet du pH sur les ions en solution. Sous des pressions négatives, les matériaux se comportent comme des membranes. Ainsi, le débit de solution ( $\text{mL}\cdot\text{h}^{-1}$ ) augmente avec la pression et la concentration des ions métalliques ( $\text{mg}\cdot\text{L}^{-1}$ ) ne montre pas de changements significatifs. De plus, un coefficient de transport ( $\text{TC}_{\text{HM}}$ ), dépendant du métal et du matériau, a été obtenu. Une valeur de  $\text{TC}_{\text{HM}}=1$  signifie qu'il n'y a pas d'interactions entre l'ion métallique et le matériau et place le matériau au niveau d'une espèce végétale hyperaccumulatrice; l'indicateur est utile pour évaluer indirectement la concentration de métal dans le sol.

En intégrant les résultats obtenus en laboratoire à un modèle conceptuel simplifié, les principes d'une technologie artificielle de phytoremédiation ont été mis en évidence. Cette technologie doit être la base pour le développement d'une nouvelle famille de technologies qui peuvent aider à réduire certains impacts négatifs sur les sols causés par les méthodes traditionnelles de décontamination.

**Mot clés :** transport capillaire, métaux lourds, sol solution, plantes hyperaccumulatrices.





# DEVELOPMENT OF AN ARTIFICIAL PHYTOREMEDIATION TECHNOLOGY FOR SOILS CONTAMINATED BY TOXIC METALS

Norma Angélica OROPEZA GARCIA

## ABSTRACT

Globally, contamination of soil and groundwater by toxic metals (Pb, As, Cr, Ni, Zn, etc.) are becoming increasingly problematic for both ecosystems and human health. Currently, phytoextraction and phytoaccumulation are studied for the decontamination of metals because they offer a treatment option at low cost. From a biomimetic approach, the general objective of this work is to propose, at a conceptual level, a new technology based on physical-chemical mechanisms of transport of contaminants by plants

In order to fulfill these objectives, an experimental arrangement was constructed in the laboratory to test some materials and operating factors. The seven metals studied and analyzed by ICP-MS were aluminum, arsenic, cadmium, chromium, nickel, lead and zinc. A cellulosic fibre (M1) and a polyester-polyamide (M2) were used as capillary means of transport due to the fact that they have a diameter similar to that of xylem vessels on the transport system of vascular plants. On the basis of a negative pressure gradient of  $0.02 \text{ MPa}\cdot\text{m}^{-1}$ , reported for vascular plants, the studied pressures were 0.011, 0.022, 0.045, 0.090 and  $0.18 \text{ MPa}\cdot\text{m}^{-1}$ , while the pH solutions were studied at 4 and 8.

The results show that the highest metal ion transport was obtained at pH 4, in ascending order:  $\text{Cr} < \text{Pb} = \text{Al} < \text{As} < \text{Ni} < \text{Zn} < \text{Cd}$  to M1 and  $\text{Cr} < \text{Pb} = \text{Al} = \text{As} < \text{Ni} = \text{Zn} = \text{Cd}$  to M2. Differences on ion transport between M1 and M2, expressed as the percentage of transported ion, are attributed to the chemical composition of the materials, due to unequal amount of active sites on the surface of each material, as well as to the effect of pH on the ions in solution. Under negative pressure, the materials showed similar behaviour to that of membranes, thus, the solution rate of flow ( $\text{mL}\cdot\text{h}^{-1}$ ) increases with the pressure while the concentration of metal ions ( $\text{mg}\cdot\text{L}^{-1}$ ) exhibited no significant variation. In addition, a transport coefficient ( $\text{TC}_{\text{HM}}$ ), in function of the metal and the material, was obtained. A value of  $\text{TC}_{\text{HM}}=1$  means that there are no interactions between the metal ion and the material and, at the same time, this value will place the material at the level of a plant species identified as hyperaccumulator; the indicator is useful to assess indirectly the concentration of metal in the soil.

By integrating the laboratory results in a simplified conceptual model, the principles of the artificial phytoremediation technology were highlighted. This technology should be the basis for the development of a new family of technologies that can help reduce some negative impacts caused by the traditional methods of soils decontamination.

**Keywords:** capillary transport, heavy metals, soil solution, hyperaccumulator plants.



## TABLE OF CONTENTS

	Page
INTRODUCTION .....	1
CHAPTER 1 LITERATURE REVIEW .....	7
1.1 Heavy metal pollution and environmental problems .....	7
1.2 Methods to remove and stabilize heavy metals in soils .....	10
1.3 Phytoremediation.....	13
1.3.1 Categories and application of phytoremediation .....	14
1.3.2 Accumulator and hyperaccumulator plants .....	16
1.3.3 Enrichment coefficient to identify hyperaccumulator species.....	18
1.3.4 Transfer of heavy metals to plants and pH conditions .....	18
1.3.5 Soil solution transport in vascular plants.....	22
CHAPTER 2 TRANSPORT OF HEAVY METALS IN MATERIALS WITH DIAMETER ANALOGOUS TO XYLEM VESSELS.....	31
2.1 Introduction .....	32
2.2 Materials and methods.....	34
2.2.1 Building of the capillary syphon .....	35
2.2.2 Transport of heavy metals .....	36
2.2.3 Determination of heavy metals.....	37
2.2.4 Statistical analysis.....	37
2.3 Results and discussion.....	37
2.3.1 Volumes of solution transported by the materials .....	37
2.3.2 Heavy metals mobility in acidic conditions .....	39
2.3.3 Heavy metals mobility in basic conditions.....	41
2.3.4 Comparison to hyperaccumulator plants .....	42
2.3.5 Heavy metals mobility and pH in soils.....	44
2.4 Conclusions .....	45
2.5 References .....	46
CHAPTER 3 HEAVY METAL TRANSPORT AS AN ANALOGY TO THE TRANSPIRATION PHENOMENON IN VASCULAR PLANTS .....	53
3.1 Introduction .....	54
3.1.1 Pressure gradient in the xylem.....	55
3.1.2 Metal hyperaccumulator plants.....	56
3.2 Materials and methods.....	56
3.2.1 Capillary means of transport.....	56
3.2.2 Heavy metal solutions .....	57
3.2.3 Assessed pressures.....	57
3.2.4 Determination of heavy metals.....	59
3.2.5 Statistical analysis.....	59
3.3 Results and discussion.....	59

3.3.1	Effect of pH on the transport of heavy metals.....	59
3.3.2	Pressure effect .....	62
3.3.3	Metals in the soil-plant system.....	64
3.3.3.1	Hyperaccumulation criteria.....	64
3.3.3.2	Mobility of heavy metals in the soil-plant system .....	65
3.4	Conclusions.....	66
3.5	References.....	67

#### CHAPTER 4 TRANSPORT COEFFICIENT FOR HEAVY METALS IN POROUS MATERIALS.....

4.1	Introduction .....	76
4.2	Materials and methods .....	77
4.2.1	Capillary means of transport .....	77
4.2.2	Heavy metal solutions .....	79
4.2.3	Pressure assumption .....	79
4.2.4	Heavy metal determination.....	79
4.2.5	Calculation of transport coefficient of heavy metals ( $TC_{HM}$ ).....	80
4.2.6	Statistical analysis .....	80
4.3	Results and discussion.....	81
4.3.1	Transport, accumulation and $TC_{HM}$ in acidic conditions .....	81
4.3.2	Transport, accumulation and $TC_{HM}$ in basic conditions.....	83
4.3.3	Transport Coefficient of heavy metals ( $TC_{HM}$ ) and Enrichment Coefficient (EC) .....	84
4.4	Conclusions .....	85
4.5	References .....	86

#### CHAPTER 5 DISCUSSION.....

5.1	A conceptual model of heavy metal transport in the soil-material continuum .....	91
5.1.1	Model approach .....	91
5.1.2	Concepts integrated in the model .....	92
5.1.3	Modeling conditions.....	93
5.1.4	Model results .....	96
5.1.5	Limitations of the model .....	99
5.2	Perspectives and recommendations.....	100
5.2.1	Artificial xylem technology by biomimicry to the soil-plant continuum.....	101
5.2.2	Bioarrangements used to prevent soil pollution .....	102
5.2.3	Heavy metal transport indicator: phytoextraction or phytostabilization .....	103

#### CONCLUSION.....

ANNEX I	Distribution of species present in the solution according to the pH.....	107
---------	--	-----

ANNEX II	Compilation of ec reported in the literature .....	109
----------	--	-----

ANNEX III	System dynamics model .....	115
-----------	-----------------------------	-----

BIBLIOGRAPHY ..... 121



## LIST OF TABLES

	Page
Table 1.1	Percentage of sites contaminated with heavy metals .....8
Table 1.2	Health effects of heavy metals .....10
Table 1.3	Soil remediation technologies .....12
Table 1.4	Cost comparison of phytoremediation to conventional methods of soil remediation for inorganic contaminants.....13
Table 1.5	Concentration ranges of heavy metals in the solution of uncontaminated soils .....20
Table 1.6	Prevalent chemical species in soils, mobility and phytoavailability .....21
Table 1.7	Content of As, Cd and Zn in different parts of the plant.....24
Table 1.8	Phytoextraction studies using hydroponic solutions .....28
Table 2.1	Properties of the tested materials for heavy metal capillary transport .....35
Table 2.2	Accumulation and hyperaccumulation levels in plants compared to the estimated levels of transport (T) and to the total sum of transport and accumulation (T+A), in acidic conditions.....43
Table 3.1	Transfer of heavy metals from soil to plants .....55
Table 3.2	Characteristics of the tested materials at negative pressure values .....58
Table 3.3	Wavelengths used for metal determination .....59
Table 3.4	Percentage of heavy metal accumulated in M1 under alkaline conditions at different pressures (P) $\pm$ standard error (from three replicates) .....63
Table 3.5	Percentage of heavy metal accumulated in M2 under alkaline conditions at different pressures (P) $\pm$ standard error (from three replicates) .....63
Table 4.1	Characteristics of the materials tested for the transport of heavy metals in solution .....78
Table 4.2	Transport coefficient obtained for the tested materials (means $\pm$ standard error from three replicates) .....81

Table 4.3	Ratio [Metal]Outlet/[Metal]soluble in the inlet solution (means $\pm$ standard error from three replicates).....	83
Table 5.1	Values of the variables considered in the model.....	96
Table 5.2	Laboratory results vs. model results.....	97
Table 5.3	Heavy metals in soil: range and regulatory limits.....	97



## LIST OF FIGURES

	Page
Figure 1.1 Heavy metal transport in the environment.....	8
Figure 1.2 Human exposition to contaminants.....	9
Figure 1.3 Mechanisms involved in the phytoremediation technologies.....	14
Figure 1.4 Classification on plants according to their metal uptake.....	16
Figure 1.5 Mobility trends of heavy metals in light mineral soil as a function of soil pH.....	19
Figure 1.6 Scheme of the vascular system of plants.....	23
Figure 1.7 Flow in the xylem.....	25
Figure 1.8 (a) Capillary tube and (b) arrangement of capillary tubes in the xylem considered as a porous media.....	26
Figure 1.9 Permeability of heterogeneous layers.....	27
Figure 1.10 Methodological approach.....	29
Figure 2.1 Capillary siphon.....	36
Figure 2.2 Cumulative volume of transported solution by the tested materials $\pm$ standard deviation (SD): (a) M1 and (b) M2.....	38
Figure 2.3 Percentage of heavy metals transported (T) and accumulated (A) by the materials: (a) in acidic conditions, (b) M1 in basic conditions, (c) M2 in acidic conditions and (d) M2 in basic conditions, bar errors represent standard deviation.....	40
Figure 2.4 Chemical structure of (a) cellulose in M1, (b) polyester 80% and (c) polyamide 20% in M2.....	41
Figure 3.1 (a) Transport of soil solution in vascular plants (a) and (b) experimental arrangement.....	58
Figure 3.2 Percentage of heavy metals transported by the tested materials: (a) M1 and (b) M2 at acidic conditions and (c) M1 and (d) M2 under alkaline conditions.....	61
Figure 3.3 Time required to displace 250 ml of solution as a function of the vacuum pressure under acidic and basic conditions through (a) M1 and (b) M2.....	62

Figure 4.1	(a) Soil solution transport in vascular systems and (b) experimental arrangement. ....	78
Figure 4.2	Total percentages of heavy metals transported and accumulated in acidic and basic conditions for M1 and M2.....	82
Figure 5.1	Diagram of the soil-material continuum. ....	93
Figure 5.2	Schema of the soil-material continuum.....	95
Figure 5.3	Behaviour of the heavy metal concentration estimated through the model. ...	98
Figure 5.4	Technology based on the phytoextraction process.....	101
Figure 5.5	Qualitative indicator of heavy metal transport.....	103

## LIST OF ABBREVIATIONS

Al	Aluminum
As	Arsenic
Cr	Chromium
Ni	Nickel
Zn	Zinc
Cd	Cadmium
Pb	Lead
Cu	Copper
Cs	Caesium
Co	Cobalt
Mn	Manganese
Mo	Molybdenum
Sr	Strontium
U	Uranium
Se	Selenium
EC	Enrichment coefficient
pH	Potential of hydrogen
M1	Material tested composed by cellulose (99%)
M2	Material tested composed by polyester (80%)-polyamide (20%)
ACFAS	Association francophone pour le savoir
STEPPE	Station expérimentale des procédés pilotes en environnement
TC <sub>HM</sub>	Transport coefficient of heavy metal
STELLA	Modeling and simulation software
ICP-OES	Inductively coupled plasma optical emission spectrometry
ANOVA	Analysis of variance
LSD-test	Least significant difference
JMP8	Statistical software
NaOH	Sodium hydroxide
HNO <sub>3</sub>	Nitric acid

HCl	Hydrochloric acid
(-NH <sub>2</sub> )	Amino group
(-OH)	Hydroxyl group
M	Molar concentration
M <sup>+</sup>	Heavy metal ion
%	Percentage
[M <sup>+</sup> ]	Metal concentration
[Metal] <sub>shoots</sub>	Heavy metal concentration in shoots
[Metal] <sub>soil</sub>	Heavy metal concentration in soil
[Metal] <sub>inlet</sub>	Heavy metal concentration inlet in the experimental arrange
[Metal] <sub>outlet</sub>	Heavy metal concentration outlet in the experimental arrange
H <sup>+</sup>	Hydrogen ion as a free proton
Trans	Metal transported by the material
Acc	Metal accumulated by the material
T+A	Addition of transported and accumulated metal by the material
BCF	Bioconcentration factor
π	pi number (3.1416)
η	viscosity
r	radius
v	flow velocity
$\left(\frac{\Delta\Psi_p}{x}\right)$ or $\left(\frac{\delta P}{\delta x}\right)$	pressure gradient
λ	wavelength
ΔHM	heavy metal variation in soil
K <sub>M1</sub>	material permeability
K <sub>SOIL</sub>	soil permeability

## LIST OF SYMBOLS AND UNITS OF MESURE

### MASS

$\mu\text{g}$	microgram
mg	milligram

### VOLUME

L	liter
mL	millilitre

### LENGTH

nm	nanometer
$\mu\text{m}$	micrometers
cm	centimeter
m	meter
km	kilometer

### TIME

s	second
h	hour

### SPEED

$\text{m}\cdot\text{s}^{-1}$	meter par second
$\text{m}\cdot\text{d}^{-1}$	meter par day

### FORCE

MPa	mega Pascal
-----	-------------

### PRESSURE

$\text{Pa}\cdot\text{m}^{-1}$	Pascal par meter
$\text{MPa}\cdot\text{m}^{-1}$	mega Pascal par meter

### CONCENTRATION

$\mu\text{g}\cdot\text{L}^{-1}$	micrograms par liter
$\text{mg}\cdot\text{L}^{-1}$	milligrams par liter
$\text{mg}\cdot\text{kg}^{-1}$	milligrams par kilogram

### RATE

t/ha-year	ton par hectare par year
-----------	--------------------------



## INTRODUCTION

Soil pollution with heavy metals has several consequences such as damage of ecosystems and of agricultural products, deterioration of the food chain, negative impacts on water resources, economic losses and adverse effects on human and animal health as a consequence of their non-biodegradability and bioaccumulation (Fellet *et al.*, 2007). Due to their toxicity, lead (Pb), arsenic (As), chromium (Cr), nickel (Ni), zinc (Zn), and cadmium (Cd) are of particular concern (Blais *et al.*, 2010). These elements may enter in the human body through skin absorption, air, water and food (UNEP and ADEME, 2006). This pollution is the result of human activities including the burning of fossil fuels, mining and military activities, pesticide dispersion, the use of pigments and batteries and many others (Leyval *et al.*, 1997).

Because heavy metals cannot be degraded, sites contaminated with this kind of elements are particularly difficult to remediate (Lassat, 2000). Commonly, metal removal from polluted sites involves excavation of contaminated soils and immobilization of metal contaminants by solidification/stabilization technologies prior to disposal of the treated materials on site or in a specialized landfill site (Blais *et al.*, 2010). Although inert forms of heavy metals can be obtained by raising the pH, or by addition of organic matter, inorganic anions or metallic oxides and hydroxides, the amounts of heavy metals in soil remains (Sinha *et al.*, 2007). On the other hand, the long-term stability of solidified or stabilized soils has been a seriously questioned aspect (Dermont, 2008).

At present, bioremediation methods like phytoextraction and phytoaccumulation are explored with a particular interest on heavy metal contaminated soils and groundwater. Although original soil properties may never be achieved once the site is contaminated, the use of phytotechnologies offers a new option for soil preservation and at a low cost, unlike conventional methods that destroy it and are expensive (Kabata-Pendias and Pendias, 2001). In this regard, most of the literature in the field exhibits case studies identifying species that are capable of extracting and accumulating metals in their tops. However, the application of phytotechnologies is complicated because generalization of the results is too difficult, many

variations in the extraction and accumulation of heavy metals can be attributed to several factors such as soil type, plant species, season, temperature, humidity, fertilizers used, etc.; even the same plant species may have many variations in the rate of metal extraction (Ibidem).

In this context, the general objective of this work was to conceptually propose a new technology based on the transport mechanisms of the soil solution described for vascular plants in phytoremediation processes.

### **Work approach: Biomimetics and innovation**

The term biomimetics involves the study of the methods, mechanisms and processes used by the nature to apply them in fields such as engineering, design, chemistry, electronics, etc. (Bar-Cohen, 2006; Helms *et al.*, 2009; Schmitt, 1969). Based on natural evolution, living organisms has tested different solutions to challenges of survival and reproduction, leaving to their younger generations those ones that have been successful (Vincent *et al.*, 2006). Biomimetics as a source of technological innovation has shown a significant rise in recent years; this may be seen in the increasing number of patents registered in the past two decades; the records contain solutions to specific problems arising from the study of biological systems (Bonser, 2006).

Three key issues have been identified for inspiration in nature: (i) Replicating natural methods of synthesis of compounds in plants and animals; (ii) Imitating or copying mechanisms found in nature; (iii) Reproducing organizational systems of social behaviour (birds, ants, bees, microorganisms, etc.) (Butler, 2005). From this approach, the hypothesis of the work were established considering:

The transport of soil solution containing nutrients and contaminants, from roots to leaves, is the result of different phenomena, among which is capillary action. The capillary pressure in the xylem vessels allows water to ascend, in a similar way as it does in a wick; this



phenomenon is explained by cohesion-tension mechanisms (Sperry, 2011). Thus, the pollutant is translocated from the soil to the tops of the plants and the contaminants removal is carried out through the harvest of biomass. Taking this as a basis, the first hypothesis was stated as follows:

### **Hypothesis 1**

By analogy to the capillary phenomenon observed in vascular plants, the translocation of heavy metals, particularly under acidic conditions, can be carried out by using materials with a diameter similar to that found in the xylem vessels.

The transpiration stream in the xylem vessels allows the transport of soil solution from the roots to the aerial parts; this suction force pulls the water column up (Kvesitadze *et al.*, 2006). Some authors have described these mechanisms as a wick, formed by the terrestrial plants, which connects the soil to the atmosphere water (Harper, 1977) and by others as a biopump capable of extracting not only water but also the pollutants contained in it (Robinson *et al.* 2003). In this respect, the xylem of vascular plants represents an interesting point because an increase in the capacity of transport would make the process of phytoextraction more efficient (McGrath and Zhao, 2003). Furthermore, similarities in the hydraulic behaviour of xylem and soil have been exposed as an area of opportunity in the soil-plant-atmosphere system (Sperry *et al.*, 2003). Based on those findings, the second hypothesis was raised:

### **Hypothesis 2**

The heavy metal transport, using materials with pore diameter in the range of those of xylem vessels of vascular plants, can be improved by applying a negative pressure similar to that observed in the process of transpiration.

For the third hypothesis of the work, the enrichment coefficient (EC), used to evaluate accumulation and hyperaccumulation capacities for the plants, was taken as reference. By analogy to this coefficient, the hypothesis stated that:

### **Hypothesis 3**

For the tested materials, a transport coefficient of heavy metals can be obtained by using the ratio of the amount of heavy metals translocated by the materials to the quantity of non-translocated metals, in order to identify the suitability of materials for the transport of heavy metals.

The thesis is composed of six chapters of which chapter one displays the literature review. Chapters two, three and four show the research articles developed from the experimental laboratory work at STEPPE. This part of the work was performed so as to replicate the transport mechanisms that take place in xylem of vascular plants. Chapter five presents the conceptual technology based on the system soil-plant-atmosphere. Finally, the last pages present some global concluding remarks of the work.

### **Chapter 1**

Summarizes the review of the literature used for the development of the work, the most important points in this chapter include soil contamination by heavy metals and current remediation processes, different phytotechnologies used in soil decontamination and capillary and transpiration mechanisms used by vascular plants for transporting the soil solution from the soil to their aerial parts.

### **Chapter 2**

Shows the research results in the article entitled “Transport of heavy metals in materials with diameter analogous to xylem vessels”. The article was submitted to the International Journal of Environmental Research. This part of the work had the aim of evaluating the capillary transport of Pb, Cr, As, Cd, Zn, Ni and Al in solutions of pH 4 and pH 8 by using two materials (M1: cellulose, M2: polyester-polyamide) with low diameter (10-30  $\mu\text{m}$ ), these sizes are in the range of the vessels found in the transport system of vascular plants. The results allowed us to identify two materials (M1 and M2) that performed better in the transport of heavy metals. The results reported in this article were presented at the 2011 ACFAS Congress that took place May 9 to 13, 2011, in Sherbrooke, Quebec, Canada.

### **Chapter 3**

Presents the research results in the article “Heavy metals transport as an analogy to the transpiration phenomenon in vascular plants” submitted to the Journal of Applied Research and Technology. By analogy to the transpiration phenomenon, the objective of this part was to investigate the effect of different negative pressure (0.011 to 0.1 MPa·m<sup>-1</sup>) on the transport of heavy metals (Pb, Cr, As, Cd, Zn, Ni and Al) using two materials (M1 and M2) at different pH solutions (pH 4 and pH 8). The results reported in this article were presented at the 2012 ACFAS Congress that took place May 7 to 11, 2012, in Montreal, Quebec, Canada.

### **Chapter 4**

Provides the research results in the article “Transport coefficient for heavy metals in porous materials” submitted to the Journal of Environmental Chemical Engineering. The objective of this part of the study was to propose and obtain a transport coefficient of heavy metals (TC<sub>HM</sub>) by analogy to the enrichment coefficient used to identify accumulator and hyperaccumulator plants species. Heavy metal solutions at pH 4 and pH 8 were passed through two materials (M1 and M2) with similar pore diameter to that found in the xylem applying a negative pressure to simulate the transpiration conditions. The materials showed their ability to transport various metals at a time, particularly under acidic conditions, a situation that rarely occurs in phytoaccumulator plants, which normally are selective for a single metal.

### **Chapter 5**

Presents a conceptual model based on the laboratory research results. The model describes the heavy metal translocation through the materials and puts forward the possibility of the removal of heavy metals available in the aqueous phase of the soil by transporting the solution through them, by analogy to the phenomena of capillarity and transpiration that allow the lift up of the soil solution through the xylem vessels until the tops of plants. The model was developed using STELLA 9.1 by Isee Systems.



## CHAPTER 1

### LITERATURE REVIEW

This chapter describes the problems associated to soil contamination by heavy metals, including the most important sources of emissions, dispersion in the environment, toxicity problems in humans and main treatment methods used for soil remediation. The last section of the chapter is focused on both phytoremediation processes as alternative treatments and transport phenomena that enable vascular plants to carry heavy metals from the roots to the aerial parts of the plant, allowing the extraction of this pollutants from the soil.

#### 1.1 Heavy metal pollution and environmental problems

Heavy metal pollution of soil and groundwater are a global environmental problem (Sun *et al.*, 2007). The term heavy metal is commonly used to define toxic metals, some metalloids, lanthanides and actinides associated with pollution and toxicity (Alloway, 1995; Appenroth, 2010; Duruibe *et al.*, 2007; Malarkodi, 2007). Because of their toxicity, heavy metals of particular concern are lead (Pb), arsenic (As), chromium (Cr), copper (Cu), nickel (Ni), zinc (Zn) and cadmium (Cd) (Blais *et al.*, 2010). Other less common toxic metals cited in the literature include aluminum (Al), caesium (Cs), cobalt (Co), manganese (Mn), molybdenum (Mo), strontium (Sr) and uranium (U) (Singh *et al.*, 2011).

Soil pollution by toxic metals (Pb, Cr, As, Cu, Cd, etc.) is a growing concern in the world and particularly in industrialized countries (Belluck *et al.*, 2006; Blais *et al.*, 2010, Dermont *et al.*, 2008; Sun *et al.*, 2007). The percentage of sites polluted with heavy metal are significant in Europe and Canada and represent around 70% in the United States (Table 1.1) (Dermont *et al.*, 2008).

Table 1.1 Percentage of sites contaminated with heavy metals  
Adapted from Dermont *et al.* (2008, p. 189)

Region/country	Number of potentially contaminated sites	Percentages of sites contaminated with metals
United States	500,000-1,000,000	69
Europe	1,000,000	31
Canada	30,000	21

Heavy metal pollution has varied sources, as Figure 1.1 shows, including municipal landfills, burning of fossil fuels, mining and military activities, pesticide dispersion, use of pigments and batteries, smelting and foundry works (Leyval *et al.*, 1997), agricultural and animal wastes, wood wastes, fertilizers and peat, atmospheric fallout among others (Dudka and Miller, 1999).

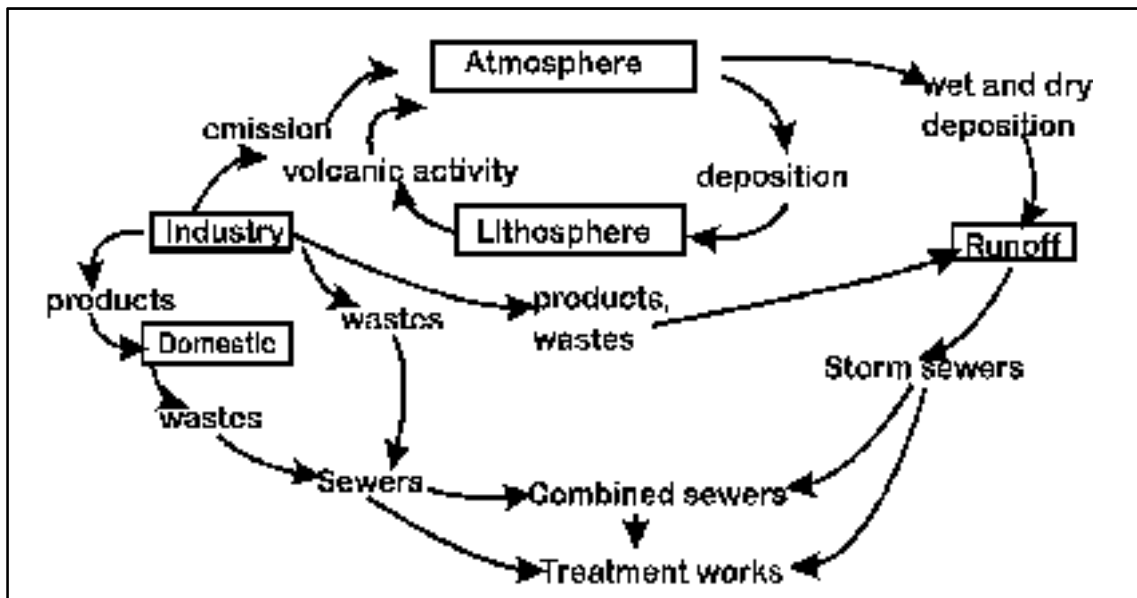

Figure 1.1 Heavy metal transport in the environment  
From Mulligan *et al.* (2001<sup>a</sup>, p. 147)

Soil pollution with heavy metals has several consequences such as damage of ecosystems, as well as affectation of production and quality of crops, deterioration of food chain, negative impacts on water resources, economic losses and adverse effects on human and animal health (Fellet *et al.*, 2007). Figure 1.2 displays the pathways of human exposition to contaminants.

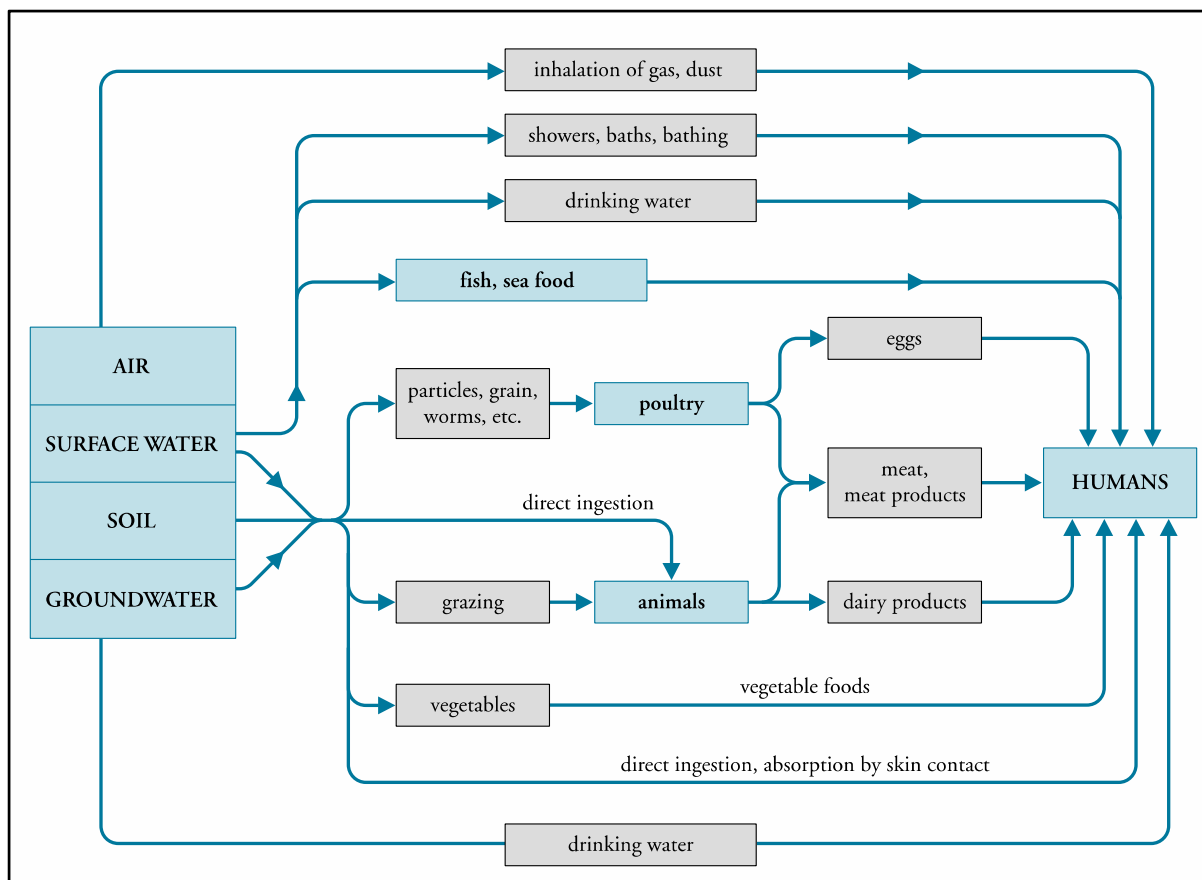

Figure 1.2 Human exposition to contaminants  
From UNEP and ADEME (2006, p. 6)

Heavy metals can enter the human body through skin absorption or by direct ingestion of water, food and air. In the human organism, the risk of this kind of pollutants is related to their ability to cause oxidative damage to living tissues (Anawar *et al.*, 2008). Some human health problems associated to toxic metal contamination are listed in Table 1.2.

Table 1.2 Health effects of heavy metals

Heavy metal	Health effects	References
Lead	Convulsions, coma, renal failure, damage to cardiovascular, central nervous system, peripheral nervous, auditory and visual systems. Particularly sensitive to this metal are fetuses and young children (neurotoxic effects).	Hu, 2002; Tremel-Schaub and Feix, 2005
Arsenic	Carcinogen, hyperkeratosis on the palms of hands and feet. Accumulation in soft tissue organs (liver, spleen, kidneys and lungs). Long-term storage in skin, hair and nails.	Tremel-Schaub and Feix, 2005; Hu, 2002
Chromium	Dermatitis, chronic ulcers of the skin, irritation of respiratory tract, rhinitis, bronchospasm, pneumonia, bronchial asthma, lung cancer. Acute poisoning causing vomiting, diarrhoea, haemorrhage and blood loss into the gastrointestinal tract, causing cardiovascular shock. Hexavalent chromium is considered carcinogenic and genotoxic.	Dayan and Paine, 2001
Nickel	Allergies, chronic ingestion can lead to lung fibrosis, cardiovascular and kidney diseases. Nickel compounds are classified as carcinogenic to humans.	Denkhaus and Salnikow, 2002
Zinc	Killer of neurons, excessive ingestion is associated with hypoglycaemia and tachycardia, gastrointestinal distress and diarrhoea and hypertension. In the human body is accumulated in the skeletal muscle, bone, brain, kidney, lung, heart, retina, pancreas, sperm, prostate and uterus.	Nriagu, 2007
Aluminum	Toxic to the central nervous, skeletal and haematopoietic systems. Studies suggest that induces nephrotoxicity and pulmonary fibrosis. Considered neurotoxic and low-level long-term exposure may be an important factor in Alzheimer's disease and related disorders.	Yokel and McNamara, 2002
Cadmium	Renal failure, bone pathology. Promotes hypertension. Considered carcinogen and leads to genotoxic effects. Loss of calcium that may lead to weakening of the bones, disease known as Itai-Itai.	Tremel-Schaub and Feix, 2005

To reduce the environmental consequences, and human health problems, different soil remediation methods are used, either to reduce the risk of dispersion or to remove such metals from soils. In all cases, the remediation method has advantages and disadvantages that should be taken into account when selecting a type of treatment.

## 1.2 Methods to remove and stabilize heavy metals in soils

Owing to heavy metals cannot be degraded, the sites contaminated with this kind of elements are particularly difficult to remediate (Lassat, 2000). As can be seen in Table 1.3, soil remediation treatments include chemical, physical and biological methods.



Soil remediation methods can be grouped as: containment methods (focused in the isolation of the contaminant), in situ (remediation without excavation of the contaminated site) and ex situ (remediation with excavation) (Gosh and Singh, 2005b). However, remediation of soils polluted with heavy metals commonly involves the excavation of the contaminated soils and the immobilization of the toxic contaminants by a solidification/stabilization technology prior to disposal of the treated materials on site or in a specialized landfill site (Blais *et al.*, 2010).

Although inert forms of heavy metals can be obtained by raising pH or by addition of organic matter, inorganic anions or metallic oxides and hydroxides, their concentration remains unchanged (Sinha *et al.*, 2007). On the other hand, the long-term stability of solidified or stabilized soils has been an aspect seriously questioned (Dermont *et al.*, 2008). Solidification/stabilisation treatments use mainly cement, lime, organic polymers and silicates as binding agents because they imply the physical or chemical bound to the contaminated soil. However, permanent immobilization of organometallic molecules cannot be assured as the presence of organic contaminants in soils may influence the solidification of the binding agents; also, the volume of the contaminated wastes can increase from 50 to 100% due to the solidifying agents and the associated technology is expensive (Environment Canada, 2012).

Table 1.3 Soil remediation technologies  
Adapted from Mulligan *et al.* (2001<sup>a</sup>, p. 161 and 2001<sup>b</sup>, p. 205)

Technology <sup>b</sup>	Description <sup>a</sup>	Applicability	Limitations
<i>Containment</i>			
Confined disposal facility and geocontainers	Retention of sediments and confined area preventing fluid flow	Wide variety of sediments, may be used as pre-treatment	Does not destroy contaminants, must control contaminant pathway
Stabilization/solidification	Creation of an inert waste	Injection of solidifying chemicals	Must contain less than 50% of moisture, organic contaminants can interfere, increases volume more than 30%
Vitrification	Application of electric power to vitrify contaminant	Shallow metal-contaminated soil, low volatility metals	High moisture and organic contents require dewatering and vapour recovery
<i>Ex situ</i>			
Physical separation	Includes, froth flotation, gravity separation, screening, etc.	Sorption or degradation of contaminants in barrier	Contaminants must be associated with fine grained material
Soil washing	Addition of surfactants and other additives to solubilize metal ions	Water soluble contaminants	Restricted to weakly bound metals
Thermal treatment	Elevated temperature extraction and processing for metal removal	Highly contaminated soil (5-20%)	High water contents increase costs
<i>In situ</i>			
Reactive barriers	Creation of a permeable barrier with zeolite, limestone, hydroxyapatite, etc.	Sorption or degradation of contaminants in barrier	Further research is required (retention time through the barrier and method to regenerating the media)
Electrokinetic	Application of electric current	Saturated soils with low groundwater flow	Mainly applicable for saturated and low permeability soils
Biological leaching	Use of microbes for metal heap leaching or in slurry reactors	Sand and gravel sized sediments and low metal contaminant levels	Not yet demonstrated at large scale
Phytoremediation	Use of plants for metal extraction	Shallow soils and water	Not yet demonstrated at large scale

Table 1.4 displays a comparison of costs of several methods used for soil remediation; as it can be seen, from the standpoint of costs, phytoremediation is very attractive because of its lower cost.

Table 1.4 Cost comparison of phytoremediation to conventional methods of soil remediation for inorganic contaminants  
From: Pilon-Smits and Freeman (2006, p. 205)

Type of treatment	Range of cost (\$/ton soil)
<b>Phytorextraction</b>	<b>25-100</b>
Soil washing	50-150
Solidification /stabilization	75-205
Soil flushing	75-210
Electrokinetics	50-300
Acid leaching/extraction	150-400
Landfilling	100-500
Vitrification	40-600

Finally, it is worth mentioning that physical or chemical remediation methods, or a combination of these, lead normally to the partial or total destruction of the soil as a natural resource. On the other hand, high costs and labour-intensive work for the preparation of sites or for the extraction of the soil are very important aspects that determine the scale of application. Unlike conventional methods, phytoremediation usually improves soil quality by introducing organic substances in it, allowing the reproduction of microorganisms, its implementation costs are much lower and, as a relatively new biotechnology, has a good public acceptance (USEPA, 2012).

### 1.3 Phytoremediation

Phytoremediation is defined as the use of plants to remove, destroy or sequester chemical contaminants located in the soil, sediments, groundwater, surface water, and even the atmosphere (Cunningham *et al.*, 1995; Raskin *et al.*, 2000; Sun, 2007). Phytoremediation is a good alternative for the remediation of soils with low concentrations of heavy metals spread over large areas and at shallow depths. Among the most important aspects to consider in a plant susceptible of being used in phytoremediation processes are extraction capacity, level

of contamination at the site (due to toxic effects on plant), adaptation to climatic conditions of the region, high biomass, compatibility with soils, growth rate, ease of planting and maintenance, and ability to take up large amounts of water through the root (USEPA, 2012).

### 1.3.1 Categories and application of phytoremediation

Although phytotechnologies are still in development, these technologies have lower costs compared to treatments commonly used in the removal of heavy metals from soils and groundwater and, furthermore, they are considered as sustainable treatments (Robinson *et al.*, 2003). Phytoremediation technologies have been applied in water, soil and groundwater polluted with heavy metals, radionuclides and organic pollutants (Ernst, 1996).

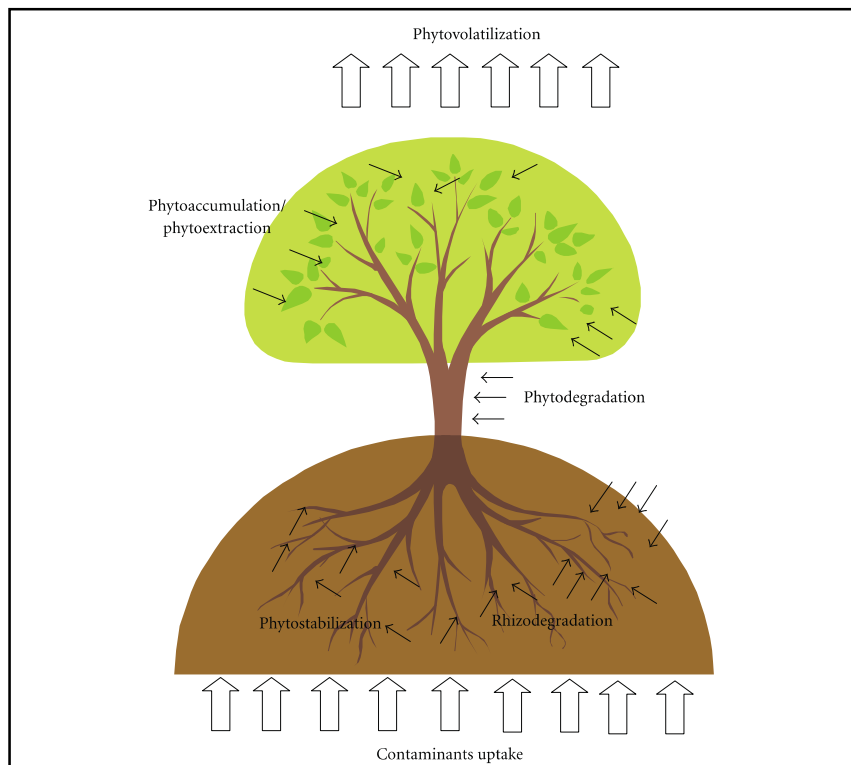

Figure 1.3 Mechanisms involved in the phytoremediation technologies  
From Tangahu *et al.* (2011, p. 6)

Depending on the type of pollutant, different phytoremediation mechanisms are involved in the process (Figure 1.3):

- 1) phytostabilization is based on the plants ability to reduce the mobility and migration of contaminants by root exudation that leads to sorption, precipitation and complexation of metals (Cunningham *et al.*, 1995; Kvesitadze *et al.*, 2006; Vidali, 2001);
- 2) rhizodegradation or phytostimulation implies the stimulation of the rhizosphere (roots) by promoting beneficial conditions for the symbiotic relationship of plants and microbes. An increase in soil activity may occur by the addition of consortia of soil microorganisms, mycorrhizal fungi biomass and exuded organic compounds (like small mass organic molecules), enzymes, carbohydrates and others (Kvesitadze *et al.*, 2006; Vidali, 2001);
- 3) phytoextraction or phytoaccumulation exploits the ability of plants to extract the contaminants from soil, sediments, groundwater or surface water. The plant transports and accumulates the contaminants in different tissues, including roots, stems, shoots or flowers (Cunningham *et al.*, 1995; Vidali, 2001; Yang, 2008). This phytotechnology has shown effectiveness in the remediation of soils contaminated by Cd, Ni, Zn, As, Se and Cu, and its application is moderately effective for Co, Mn, Fe and less effective with Pb, Cr and U (Kvesitadze *et al.*, 2006);
- 4) phytodegradation or phytotransformation usually involves the uptake, accumulation and subsequently, transformation of organic toxic contaminants from soil, air and water to more stable or less toxic substances (Cunningham *et al.*, 1995; Vidali, 2001);
- 5) rhizofiltration or phytopumping is used in water remediation; this phytotechnology involves the cultivation of accumulator plants for absorbing or adsorbing metals into the plant roots (Anawar *et al.*, 2008; Kvesitadze *et al.*, 2006).

6) phytovolatilisation refers to the uptake of volatile organic compounds or metals such as selenium and mercury by the plant, while, the contaminants are released into the atmosphere via transpiration. This technology removes the contaminant from the soil and groundwater (Kvesitadze *et al.*, 2006; Vidali, 2001).

### 1.3.2 Accumulator and hyperaccumulator plants

In plants, the ability to accumulate high concentrations of heavy metals is a rare phenomenon. Concentrations in the aerial parts of accumulator plants can be from 100 to 1,000 times higher than in non-accumulating plants (Clemens *et al.*, 2002; Krämer, 2003).

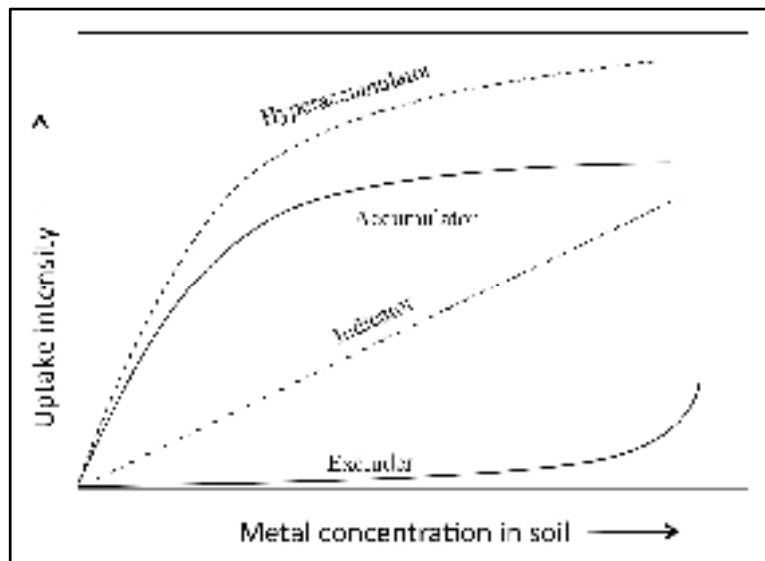

Figure 1.4 Classification of plants according to their metal uptake  
From Adriano (2001, p. 65)

Plants growing in soils contaminated with heavy metals can be classified into four categories, see Figure 1.4:

- excluders: these species restrict the absorption of metals, which enables them to maintain relatively low concentrations inside (Baker, 1981);
- indicators: these plants reflect in their biomass the concentration of metals in the soil (Ibidem);
- accumulators: these species have the capacity to absorb and accumulate metals in a wide range of concentrations with no symptoms of toxicity (Baker, 1981; Brooks *et al.*, 1977);
- hyperaccumulators: this term is used for plants which are capable to tolerate and accumulate extreme quantities of heavy metals in their shoots, this kind of species are rare and often found endemic in polluted areas (Baker, 1981). The criteria to define hyperaccumulation are: concentration  $> 10 \text{ mg}\cdot\text{kg}^{-1}$  for Hg; concentration  $> 100 \text{ mg}\cdot\text{kg}^{-1}$  for Cd; concentration  $>1000 \text{ mg}\cdot\text{kg}^{-1}$  for Cu, Cr, Ni, Co, As and Se; concentration  $>10,000 \text{ mg}\cdot\text{kg}^{-1}$  for Zn and Mg, all in dry matter of plant (Bech *et al.*, 2012; Usman *et al.*, 2012).

Usually, soils contaminated with metals possess high concentrations of these elements and contain more than one metal. Under these conditions, the application of accumulator plants presents certain disadvantages such as low growth rate, small amounts of harvestable biomass to extract heavy metals (4 t/h-year in field and 15-18 t/h-year in greenhouse) (Ernst, 2005), utilisation restricted to natural habitats because most of them are endemics to the type of soil in which they are found (Brooks, 1994), and selectivity to absorb only one heavy metal providing a partial solution to the problem (Ernst, 2005; Kamnev and Van der Lelie, 2000; Mudgal *et al.*, 2010).

### 1.3.3 Enrichment coefficient to identify hyperaccumulator species

Several plants are identified as hyperaccumulators by testing their bioconcentration factor (BFC), also called enrichment coefficient (EC) (Yanqun, 2004), which is defined as the ratio of plant metal concentration to soil metal concentration (Ghosh and Singh, 2005a), thus  $EC = \frac{[Metal]_{shoots}}{[Metal]_{soil}}$ , or as the metal concentration in the plant's harvestable tissues to the concentration of the element in the external environment (Liao *et al.*, 2004).

EC reflects the effectiveness of a plant for transporting metals from the contaminated medium, soil or water, to the top of the plant (Abhilash *et al.*, 2009; Branquinho *et al.*, 2007; Haque *et al.*, 2008;). Through EC, plants can be classified as accumulators ( $EC > 1$ ), indicators ( $EC = 1$ ) or excluders ( $EC < 1$ ) (Baker, 1981; Branquinho *et al.*, 2007). Several examples of EC are displayed in Annex II; as it can be seen, very few species show an  $EC > 1$ .

### 1.3.4 Transfer of heavy metals to plants and pH conditions

For plants, heavy metals bioavailability is closely related to their solubility in the aqueous phase, this is why phytoremediation of water contaminated with heavy metals is readily achieved; nevertheless, in soils, the plant must first solubilise heavy metals and then it should be able to transport them to its aerial parts (Brooks and Robinson, 1998). The same idea is expressed as: "The aqueous phase provides a mobile medium for chemical reactions, metal transfer and circulation through the soil to organisms, and also to the aquatic environment" (Violante, 2010, pp. 268).

Redox status, pH, organic matter content and concentrations of other ions are among the factors influencing the bioavailability of heavy metals for plants (Krishnamurti and Naidu, 2008); however, soil pH is considered the most important parameter affecting the heavy metal accumulation in plants (Kashem and Singh, 2002; Kirkham, 2006; Shah *et al.*, 2010). Usually, soluble compounds are formed at lower soil solution pH; as a result of this, metal bioavailability increases for plants and, on the contrary, fewer soluble compounds are formed



at higher soil solution pH, which reduces the heavy metal uptake by plants (Seregin and Ivanov, 2001). As an example, for the same soil, at very acidic conditions, concentration of soil solution (the sum of Fe, Mn, Zn, Pb, Cu and Cd) was reported as high as  $9080 \mu\text{g}\cdot\text{L}^{-1}$ , but, at neutral pH, the reported value was  $17 \mu\text{g}\cdot\text{L}^{-1}$  (Kabata-Pendias and Pendias, 2001). Hence, the uptake rate of heavy metals by plants depends on the concentrations of heavy metals in the soil solution. The importance of pH, in the contaminant transfer, is highlighted in the following paragraph and is displayed in Figure 1.5.

“The pH of the soil or nutrient solution is a significant factor during the absorption of toxic compounds by the root system. In particular, the following factors controlling absorption by roots depend of pH: adsorption of contaminants by soil particles; mobility of contaminant molecules in the soil, degree of dissociation of ionogenic molecules and permeability of absorptive root tissues.” (Kvesitadze *et al.*, 2006, pp. 63)

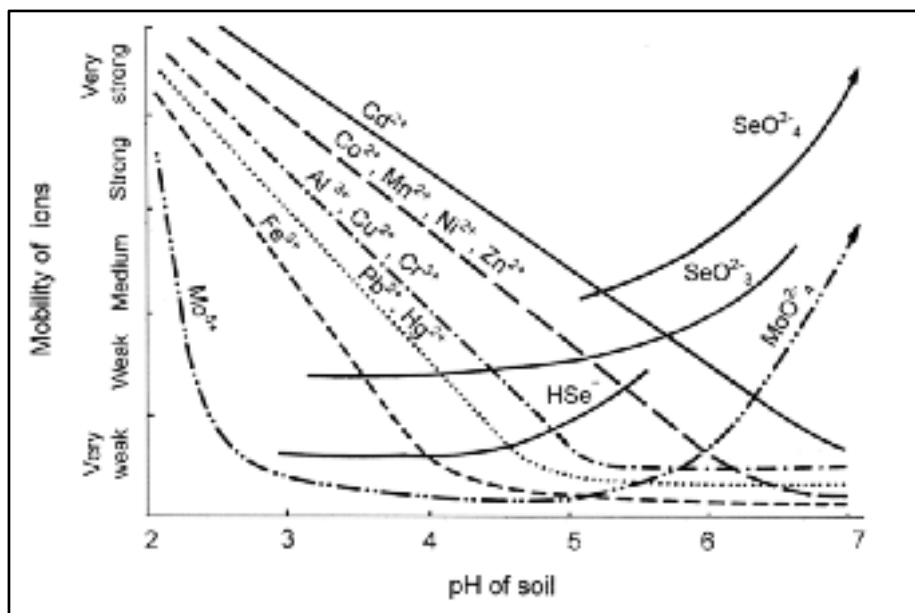

Figure 1.5 Mobility trends of heavy metals in light mineral soil as a function of soil pH  
From Kabata-Pendias and Pendias (2001, p. 52)

To date, the chemical behaviour of heavy metals in soils is insufficiently known. The concentration of heavy metals in the soil solution fluctuates considerably depending on the elapsed time since contamination occurred, season, vegetation, microbial activity, waterlogged conditions and heterogeneity of the solid phase. Thus, the concentration of heavy metals in the soil solution can be changed more than tenfold by rainfall, evaporation and plant transpiration (Kabata-Pendias and Pendias, 2001).

Finally, it is worth to note that the solubilisation of heavy metals in the soil solution makes possible the migration of these metals and its bioavailability for plants. However it should be considered that the heavy metals replenishment depends on the rate of transfer from the solid phase to the aqueous phase which is affected by factors such as organic matter formation and decomposition, exchange and adsorption by organic matter, fixation and release by microbiota, exchange with the gaseous phase, exchange and adsorption by the minerals constituents, precipitation and mineral formation, uptake and release by plants (Kabata-Pendias and Pendias, 2001; Kashem and Singh, 2002; Krishnamurti and Naidu, 2008). Accordingly, the bioavailability of heavy metals in soils is not constant and is not easy to predict. For uncontaminated sites, estimated values of heavy metal concentrations in the soil solution vary from 1 to 100  $\mu\text{g}\cdot\text{L}^{-1}$ , but these values can be much higher in contaminated soils (Kabata-Pendias, 2004). Concentrations of some heavy metals, measured in the soil solution of uncontaminated soils, are showed in Table 1.5.

Table 1.5 Concentration ranges of heavy metals in the solution of uncontaminated soils  
Compiled from Kabata-Pendias and Mukherjee (2007, p. 16-25)

Heavy metal	Concentration range $\mu\text{g}\cdot\text{L}^{-1}$	Range most commonly reported $\mu\text{g}\cdot\text{L}^{-1}$
B	5-800	
Cd	0.08-5	0.01-7
Co	0.08-29	0.05-100
Cr	0.01-29	0.05-100
Cu	0.5-135	0.05-100
Mn	25-8000	40-10000
Mo	0.0004-30	0.05-100
Ni	0.2-150	0.05-100
Pb	0.005-63	0.05-100
Zn	0.1-750	1-900

Table 1.6 Prevalent chemical species in soils, mobility and phytoavailability  
Adapted from Tremel-Schaub and Feix (2005, p.57-64 ) and \*Vitarello *et al.* (2005, p. 131)

Heavy metal	Prevalent chemical species in soils	Mobility and phytoavailability
Pb	Pb(II): $Pb^{2+}$ , $PbHCO_3^+$ , $PbOH^+$ , $PbS$ , $PbSO_4$ , $Pb(OH)_2$ , $PbCO_3$ , $PbO$ , $Pb(PO_4)_2$ , $PbCl^+$ .	Low mobility. Pb is poorly absorbed by the roots of plants, where it is normally retained.
Ni	Ni(II): $Ni^{2+}$ , $NiSO_4$ , $NiSO_4$ , $NiHCO_3^+$ , $NiCO_3$ .	Medium mobility. Plants easily absorb Ni.
Zn	Zn(II): $Zn^{2+}$ , $ZnSO_4$ , $ZnHCO_3$ , $ZnCO_3$ , $ZnFe_2O_4$ , $Zn_2SiO_4$ , $Zn_3(PO_4)_2$	High mobility Minimal concentration of Zn in solution is found at pH between 7 and 8, whereas at $pH < 6$ , the concentration of Zn increases considerably. Plants easily absorb Zn. Low mobility
*Al	Al(III): $Al^{3+}$ , $AlOH^{2+}$ , $Al(OH)_3$ , $Al(OH)_4^-$	Al is found soluble in soils in acidic pH between 3 and 4.5. Toxic species of Al are $Al^{3+}$ and $AlOH^{2+}$ . Al damages the root of the plant where is normally retained; its transport to the leaves is very low.
As	<i>In oxidizing conditions:</i> As(V): $H_2AsO_4^-$ is prevalent in acidic conditions, $HAsO_4^{2-}$ is prevalent in alkaline conditions. <i>In a reducing environment:</i> As(III): $HAsO_2$ , $AsO_2^-$	As(V) species are less soluble and toxic as compared to As(III). As precipitates with Fe and Al hydroxides. As(V) precipitation is more effective than As(III). Acidic pH ( $< 5$ ) and basic ( $pH > 8$ ) favour its absorption by plants
Cr	Cr (III) is the most stable and common form as insoluble oxide precipitate Cr(VI): $HCrO_4^-$ , $CrO_4^{2-}$ , mainly of anthropogenic pollution	Low mobility. Cr(VI) is considered the most toxic form of Cr. Cr(III) co-precipitate with several metallic hydroxides. Cr(VI) may co-precipitate with Al hydroxide at pH between 7 and 9.4. Phytoavailability of Cr is very low when compared to other heavy metals. Cr(III) usually remains in the roots of plants and Cr(VI) is commonly transported to the tops. Cr in neutral or basic conditions is more phytoavailable than in acidic conditions.
Cd	Cd(II) $Cd^{2+}$ , $CdSO_4$ , $CdCl^+$ , $CdHCO_3^+$ , $CdO$ , $CdO_3$ , $Cd(PO_4)_2$ , $CdS$ , $CdCl_2$	Cd is a very mobile element in soils. Cd co-precipitate with Al hydroxide. pH is the most important factor in the phytoavailability of this element. Cd concentration in the soil increases considerably at $pH < 6$ .

Heavy metals in soils may be present with different oxidation states such as As (III and V) and Cr (III and VI). In other cases, the metal shows only one oxidation state such as Cd (II), Ni (II), Pb (II), Zn (II) and Al (III). Such oxidation states largely depend on the pH of the medium. Table 1.6 exhibit the predominant chemical species of heavy metals in soil and some aspects of mobility and bioavailability to plants.

Up to date, most of the analyzes applied for determining the concentration of heavy metals in soils involve their solubilisation by using strong acids to quantify the total amount of heavy metal; nevertheless, these kind of tests cannot distinguish between the mobile and immobile fraction found in the aqueous phase of the soil (Hsiu-Chuan *et al.*, 2006; Violante *et al.*, 2010). On the other hand, the mobility of metals in the environment does not have a constant value (Hsiu-Chuan *et al.*, 2006). Besides other factors (pH, presence of organic or inorganic ligands, biotic or abiotic redox reactions, etc.), plants continuously affect the concentration and metal speciation in polluted soils and waters (Ernst, 1996). At the same time, metals accumulated in the aerial parts of plants are annually recycled to the soils (Yanqun, 2005; Environment Canada, 2000). For these reasons, the present work was focused solely in determining the metal ion transport through the materials and speciation analyses were not performed. Nevertheless, the chemical equilibrium diagrams can provide insight into the distribution of species present in the soil solution according to the pH of the soil. As well as, the pH value at which the metal begins to precipitate in solid (c) or crystalline (cr) form (see Annex I).

### **1.3.5 Soil solution transport in vascular plants**

In vascular plants, the translocation of heavy metals depends on the vascular system comprising the phloem, the xylem and the transpiration rate (Anawar *et al.*, 2006; Kvesitadze *et al.*, 2006). The phloem is constituted of sieve tube segments; their function is the transport of assimilates (glucose, amino acids, hormones, etc.) produced during the photosynthesis process from the leaves to the roots (Kavesitadze *et al.*, 2006). The xylem consists of a permanent interconnected tubes system that connects the roots to the leaves (Kvesitadze *et*

*al.*, 2006). Xylem has the primary function of transporting large quantities of water and solutes (Figure 1.6) (Boer and Volkov, 2003).

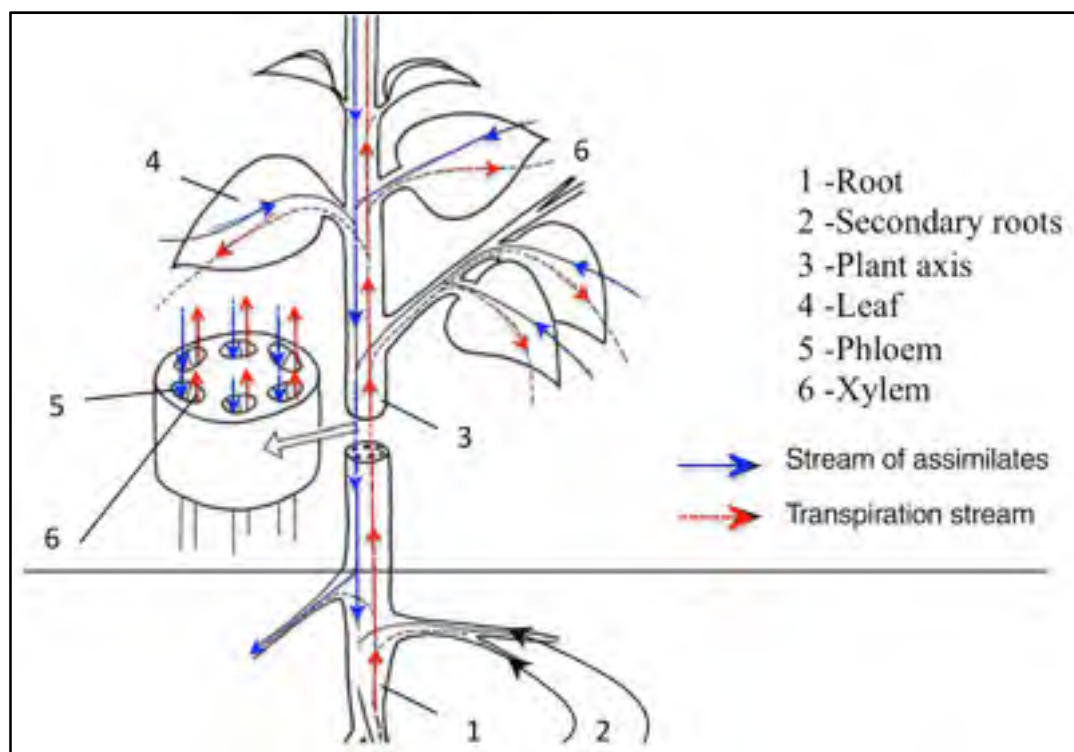

Figure 1.6 Scheme of the vascular system of plants  
Adapted from Kavesitadze *et al.* (2006, p. 73)

Similarly to nutrients, contaminants enter the plant root through the soil solution and they move towards the xylem, mainly by the apoplast (outside the cell, between the cell membranes), and in small quantities by the symplast (inside the cell, crossing the cell membranes) (Kavesitadze *et al.*, 2006; Tremel-Schaub and Feix, 2005; Wu *et al.*, 1999). The absorption process depends on many factors like contaminant concentration, polarity, pH, temperature, soil humidity etc.; however, molecular mass is the main limiting factor in the passage of substances into roots (Kavesitadze *et al.*, 2006). On the other hand, the redistribution of heavy metal in the different parts of plants and the accumulated amounts vary considerably for each element, type of plant and environmental conditions (Kabata-Pendias and Pendias, 2001), see Table 1.7.

Table 1.7 Content of As, Cd and Zn in different parts of the plant in dry matter  
 Compiled from: Tlustos *et al.*(2002, p. 53-84 )

Parts of plants	Spinach	Radish	Carrot	Bean	Oat	Wheat	Barley	Maize
<b>As (mg·kg<sup>-1</sup>)</b>								
Secondary roots	8.896	8.602	6.270					
Roots	0.696	1.008	0.110	1.072	0.233	3.691	2.414	2.450
Plant	0.166	0.904	0.401	1.085	0.218	0.570	0.247	0.200
Shelves				0.113				
Seeds				0.008		0.130	0.150	
<b>Cd (mg·kg<sup>-1</sup>)</b>								
Secondary roots	1.422	0.710	1.942					
Roots	0.161	0.131	0.111	0.662	0.574	0.276	0.311	0.370
Plant	0.489	0.353	0.353	0.072	0.195	0.162	0.117	0.052
Shelves				0.002				
Seeds				0.014		0.075	0.040	
<b>Zn (mg·kg<sup>-1</sup>)</b>								
Secondary roots	113.5	100.2	292.3					
Roots	51.3	12.9	10.1	146.9	60.7	113.2	41.9	37.5
Plant	119.7	17.0	16.7	34.5	42.5	24.2	20.7	25.4
Shelves				30.7				
Seeds				53.8		57.1	33.3	

The transport of the soil solution from the root to the leaves is the result of different phenomena, among which are capillary action and transpiration (Figure 1.7). The capillary pressure inside the xylem vessels allows water to ascend, as it does in a wick; this phenomenon is explained by cohesion-tension mechanisms (Sperry, 2011) and is defined as an spontaneous process: “wicking is the spontaneous flow of a liquid in a porous substrate, driven by capillary forces” (Tavisto *et al.*, 2003, pp. 25).

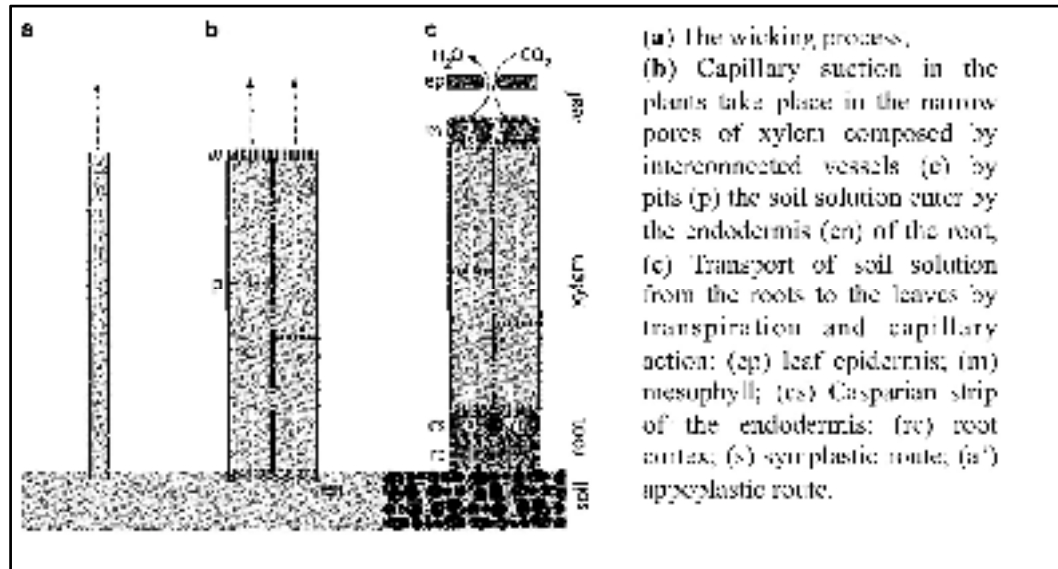

Figure 1.7 Flow in the xylem  
From Sperry (2011, p. 305)

The transpiration stream inside the xylem vessels allows the transport of soil solution from the roots to the aerial parts of plants; this suction force pulls the water column up (Kvesitadze *et al.*, 2006). Some authors have described this mechanism as a wick, formed by the terrestrial plants, which connects the soil to the atmosphere water (Harper, 1977) and by others as a biopump capable of extracting not only water but also the pollutants contained in it (Robinson *et al.*, 2003).

The calculation of the theoretical and experimental flow, as well as the hydraulic conductivity, in the xylem of vascular species has been studied through the application of the Hagen-Poiseuille's Law (Eq. 1.1) and Darcy's Law (Eq. 1.2) (Boer and Volkov, 2003). Thus, equation 1.1 determines the flow driven by a capillary tube and equation 1.2 is applied to determine the flow in the xylem considered as a porous media (Sperry *et al.*, 2003), see Figure 1.8.

$$F = \frac{-\pi r^4 \delta P}{8\eta \delta x} \quad (1.1)$$

Where:  $F$  = volumetric rate of flow ( $\text{m}^3 \cdot \text{s}^{-1}$ ),  $r$  = vessel radius (m),  $\eta$  = viscosity ( $\text{Pa} \cdot \text{s}$ ) and  $\left(\frac{\delta p}{\delta x}\right)$  = pressure gradient ( $\text{Pa} \cdot \text{m}^{-1}$ ).

Darcy's law is widely used to understand the movement of water in porous media, especially in soils.

$$Q = KA \frac{\delta P}{\delta x} \quad (1.2)$$

Where:  $Q$  = volumetric rate of flow ( $\text{m}^3 \cdot \text{s}^{-1}$ ),  $K$  = hydraulic conductivity or permeability ( $\text{m} \cdot \text{s}^{-1}$ ),  $A$  = section ( $\text{m}^2$ ) and  $\left(\frac{\delta P}{\delta x}\right)$  = pressure gradient ( $\text{Pa} \cdot \text{m}^{-1}$ ).

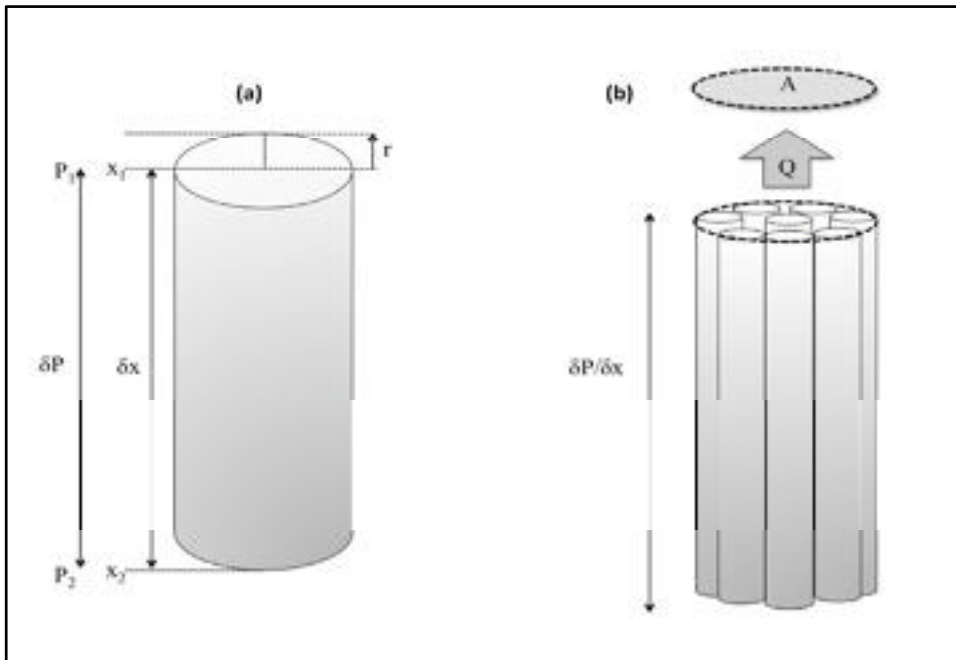

Figure 1.8 (a) Capillary tube and (b) arrangement of capillary tubes in the xylem considered as a porous media



The flow through heterogeneous layers (with different hydraulic conductivity) can be calculated with the Darcy's law considering the global permeability according to the thickness and permeability of each layer by using equation 1.3.

$$K_v = \frac{B}{\sum \frac{b_i}{K_i}} \quad (1.3)$$

Where,  $K_v$  = vertical conductivity,  $B$  = total column thickness (m),  $b_1$  = thickness of layer 1 (m),  $b_2$  = thickness of layer 2 (m),  $K_1$  = hydraulic conductivity of layer 1 ( $\text{m}\cdot\text{d}^{-1}$ ) and  $K_2$  = soil hydraulic conductivity of layer 2 ( $\text{m}\cdot\text{d}^{-1}$ ), as Figure 1.9 shows.

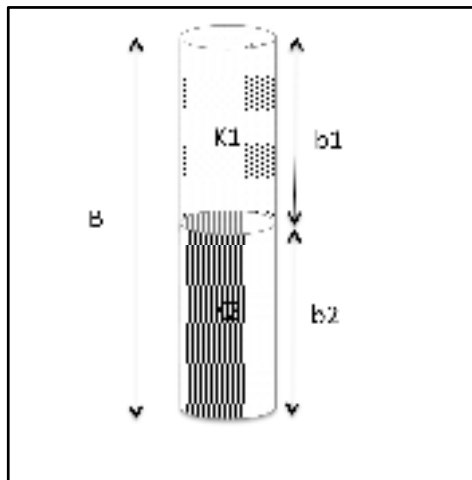

Figure 1.9 Permeability of heterogeneous layers

In this regard, the xylem of vascular plants represents an interesting point, because an increase in the capacity of transport would make more efficient the process of phytoextraction (McGrath and Zhao, 2003). Furthermore, similarities in the hydraulic behaviour of xylem and soil have been exposed as an area of opportunity in the soil-plant-atmosphere system (Sperry *et al.*, 2003); according to these authors: “the behaviour of water in soil and in xylem is strikingly identical, making it possible to model xylem flow with the same quantitative precision as soil flow” (Sperry *et al.*, 2003, pp. 1362) and “the difference is

that the pore space in the xylem is much more highly organized than in soil” (Sperry *et al.*, 2003, pp. 1363).

In natural environments, the plant’s responses to heavy metals in soils must be always investigated for each particular soil-plant system (Kabata-Pendias and Pendias, 2001). That is the reason why, on the one hand, many studies have been performed using hydroponics solutions with no soil supporting the root systems (Table 1.8), minimizing the interactions in the matrix soil-heavy metal and focussing in the accumulation and translocation of heavy metal by the plant (Baldwin and Butcher, 2006). On the other hand, this also explains why, in the literature, a countless number of case studies difficult to generalize to different conditions are reported.

Table 1.8 Phytoextraction studies using hydroponic solutions

Heavy metal	Specie	Reference
Al, Cd, Cr, Cu, Pb, Ni, Zn	<i>Asystassia Intrusa and Scindapsus Pictus Var Argyaeus</i>	Latiff <i>et al.</i> , 2012
Cd, Cu	<i>Azolla filiculoides</i>	Valderrama <i>et al.</i> , 2012
As	<i>Lupinus albus L.</i>	Moreno-Jiménez <i>et al.</i> , 2010
Ni, Pb	<i>Helianthus annuus L.</i>	Mukhtar <i>et al.</i> , 2010
Cd, Cr, Ni, As	<i>Helianthus annuus</i>	January <i>et al.</i> , 2008
Pb, Zn, Cd	<i>Cyunara cardunculus L.</i>	Hernández-Allica <i>et al.</i> , 2007
As (III)	<i>Pteris vittata and Pteris cretica</i>	Baldwin and Butcher, 2007
Fe, Zn, Cu, Hg	<i>Myriophyllum aquaticum, Ludwigina palustris and Mentha aquatic</i>	Kamal <i>et al.</i> , 2004
Ag, Cd, Cr, Cu, Hg, Ni, Pb, Zn	<i>Pistia stratiotes</i>	Objegba and Fasidi, 2004
Pb, Cd	Radish	Chen <i>et al.</i> , 2003
Cd, Cr, Cu, Pb, Ni	<i>Salix viminalis and Salis triandra</i>	Watson <i>et al.</i> , 2003

In this context, the present work was developed based on some conditions found in the water transport system of vascular plants, chiefly in the xylem, which allow them to carry heavy metals from the roots to their aerial parts, and on properties that enable the use of these plants in different phytoremediation technologies. The first paper shows the effect of pH (4 and 8) on the transport of heavy metals using M1 and M2, with analogous diameter to xylem vessels, as a mean of transport. A solution with the same concentration of heavy metals was tested. The second article exhibits the negative pressure effect, as an analogy to the transpiration phenomenon, on the transport of heavy metals by using M1 and M2 in acidic and alkaline conditions. The third article presents a transport coefficient of heavy metals ( $TC_{HM}$ ) in acidic and alkaline conditions obtained by analogy to the enrichment coefficient (EC) reported to identify accumulator and hyperaccumulator plant species. Figure 1.10 displays the summary of the methodological approach of the work; details of the methodology are presented in the sections “Materials and Methods” of Chapters 2, 3 and 4 for first, second and third article, respectively.

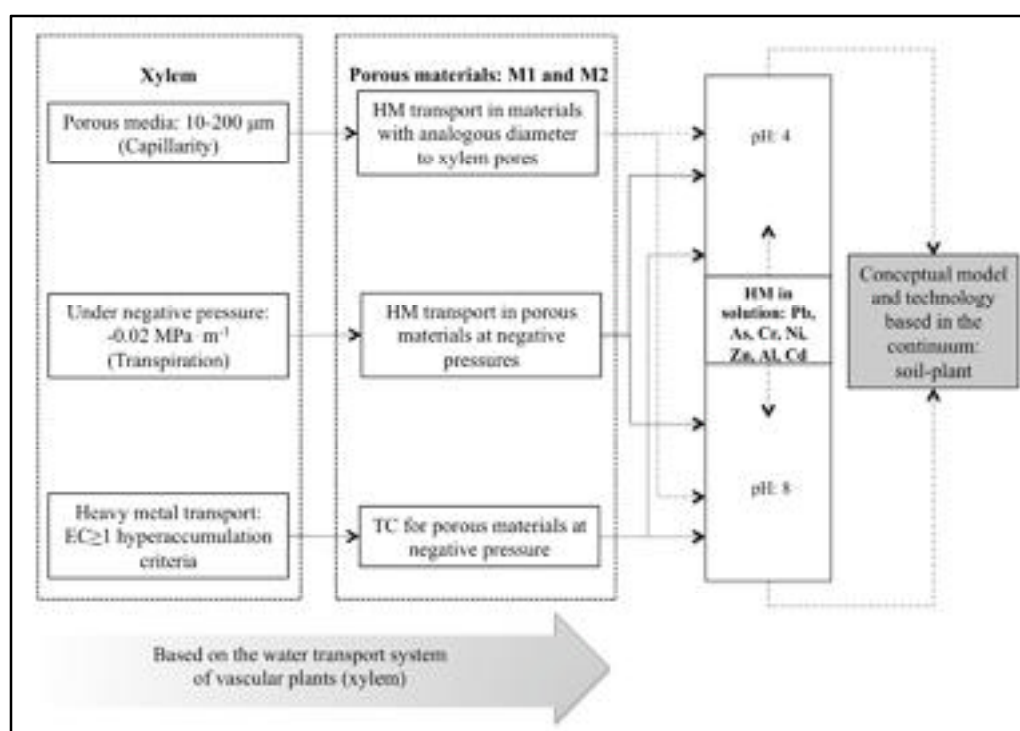

Figure 1.10 Methodological approach



## CHAPTER 2

### TRANSPORT OF HEAVY METALS IN MATERIALS WITH DIAMETER ANALOGOUS TO XYLEM VESSELS

<sup>a</sup>Norma Oropeza, <sup>b</sup>Robert Hausler, <sup>c</sup>Mathias Glaus, <sup>d</sup>Ricardo Vega, <sup>e</sup>Rabindranarth Romero

<sup>a, b, c, d</sup> Station expérimentale des procédés pilotes en environnement, École de technologie supérieure, Université du Québec, Canada, 1100, rue Notre-Dame Ouest, H3C 1K3, Montréal, Québec, Canada.

<sup>e</sup>Universidad Veracruzana, Facultad de Ingeniería Civil, Lomas del Estadio s/n 91000, Zona Universitaria, Xalapa, Veracruz, México.

This article was accepted for publication with minor corrections in the International Journal of Environmental Research; On date: 2013-03-31; Manuscript confirmation: 4113-IJER

#### **Abstract**

In vascular plants, the soil solution is transported from the roots to the leaves through small diameter vessels found in the xylem; this transport not only allows the nutrient uptake but also the accumulation of heavy metals in their shoots. By analogy to this phenomenon, the present study aimed at the evaluation of the transport of heavy metals (Pb, Cr, As, Cd, Zn, Ni and Al) in solutions of pH 4 and 8 using a capillary siphon consisting of small pore diameter materials. Determination of the metal concentration in the solutions was performed by means of Inductively Coupled Plasma. The largest transport of metal ions is produced at pH 4, on ascending order: Cr<Pb=Al<As<Ni<Zn<Cd. Results showed that there is capillary transport of aqueous solutions with heavy metals in materials with diameter similar to that found in the xylem of plants. Some authors have argued that there is a remarkable similarity between soil and xylem, which makes possible the the soil-plant-atmosphere continuity; in this sense, the performance of the tested materials should be investigated under similar conditions to those present in the interface soil-xylem to attempt to replicate this continuity.

**Keywords:** capillary transport, heavy metals, small pore diameter materials, soil solution, hyperaccumulator plants.

## 2.1 Introduction

Soil pollution by toxic metals (Pb, Cr, As, Zn, Ni, Cd, etc.) is a growing preoccupation in the world that strongly affects industrialized countries (Belluck, 2006; Blais, 2010; Dermont *et al.*, 2008; Sun *et al.*, 2007). Given that heavy metals are not biologically degraded, the main problem with this type of elements stems from their mobility and their capacity of bioaccumulation in living organisms, starting with vegetables, which are placed at the beginning of the food chain (Garbisu and Alkorta, 2001; He *et al.*, 2005; Pilon-Smits and Freeman, 2006).

The bioavailability of heavy metals is determined by their redistribution between the solid and aqueous phases of the soil. Because vegetable roots take up only the elements in the soil solution, the content of heavy metals in the aqueous phase of soils is essential in the soil-plant transfer (Bourrelier *et al.*, 1998; Fritioff and Greger, 2003; Girard *et al.*, 2005).

A fundamental factor for heavy metal solubilization is pH (Ghorbani, 2008; Ghosh and Singh 2005b; Kabata-Pendias and Pendias, 2001). In soils, the pH range is commonly found between 3.5 and 9 (USDA, 1998) and, generally, low pHs increases the bioavailability of metals (Alloway and Jackson, 1991; Kashem and Singh, 2001; Rachou and Sauv e, 2008; Sinha *et al.*, 2007). Thus, the transfer of metals towards plants has been described qualitatively as high for Zn, Ni and Cd and medium for Cr, Pb and As, in acidic conditions, while Pb, Cd, Zn and As exhibit low transfer and Cr, Ni and Al very low transfer, in basic conditions (Tremel-Shaub and Feix, 2005).

For the plant, heavy metals bioavailability is closely related to their solubility in the aqueous phase. Usually, soluble compounds are formed at low pH soil solution; as result of this, metal bioavailability increases for plants, and, on the contrary, fewer soluble compounds are

formed at high pH soil solution, which reduces the heavy metal uptake by plants (Seregin and Ivanov, 2001). Table 1.6 exhibits the predominant heavy metals chemical species in soils and some aspects of mobility and bioavailability related to plants.

In this regard, plants have developed several strategies to reduce or increase the mobility of components retained in the solid phase of the soil by changing the soil pH, such as chelating biosurfactants secretion, exudates and sugars, among other substances (Barcelo and Poschenrieder, 2003; McGrath *et al.*, 2002; Singh *et al.*, 2007;). From there, the pollutant in the soil reaches the plants roots through mass flow and diffusion phenomena. Once in the rhizosphere, lipophilic pollutants cross through the root by the symplasmic way (inside the cells), and the hydrophilics by the apoplasmic way (between the cell membranes) until they reach the xylem (Padmavathiamma and Li, 2007).

Xylem consists of sap-conducting vessels composed of cellulose (De Boer, 2003; Wu *et al.*, 1999) which very small diameter (10-200  $\mu\text{m}$ ) (Hacke *et al.*, 2006) allows them to transport the soil solution (or the xylem sap) to the aerial parts of vascular plants by means of capillary action and transpiration (Campbell and Reece, 2004; Kvesitadze *et al.*, 2006; Nijsee, 2004). Some authors have pointed out the similarities between the hydraulic conductivity of soils and that of the xylem of vascular plants, which make possible the soil-plant-atmosphere continuity (Sperry *et al.*, 2003). This mechanism has also been described as a sort of wick, which communicates the soil to the atmosphere (Harper, 1977).

The same phenomenon of capillary transport, but without the intervention of roots, takes place in the transfer of water with dissolved salts from the soil to the walls of buildings, resulting in efflorescence or saltpeter. The phenomenon is also observed in materials such as wood, concrete, mortar and bricks. The water height that could be reached by capillarity, theoretically estimated, is around 10 km for concrete and 122 m for wood (Lstiburek, 2007).

In turn, the amount of metal that can be taken up by plants depends on both the environmental conditions and the plant species. The term hyperaccumulation is commonly

used to define the capability of plants to accumulate exceptionally high quantities of heavy metals. The qualification of “hyperaccumulator plants” is generally given to species that absorb above  $1000 \text{ mg metal}\cdot\text{kg}^{-1}$  in dry weight of plant tissue (Environment Canada, 2003; Gisbert *et al.*, 2008; Shah *et al.*, 2010). Thus, levels of hyperaccumulation for Zn, reach more than  $10000 \text{ mg}\cdot\text{kg}^{-1}$ , for Pb, Ni, As, Al and Cr, they are greater than  $1000 \text{ mg}\cdot\text{kg}^{-1}$ , while for Cd, they surpass  $100 \text{ mg}\cdot\text{kg}^{-1}$  (Shah *et al.*, 2010), these kind of plants usually exhibit concentration of heavy metals in the shoots higher than in their roots and have a high tolerance to toxic metals compared to other species (Wei *et al.*, 2006)

In this context, by analogy to the transport mechanism in vascular plants, this work aimed at assessing the transport of heavy metals from aqueous solutions with pH 4 and pH 8 using a capillary siphon (Guo and Cao, 2005) as means of transport in order to test the effective transport of heavy metals in wicks composed of a natural and a synthetic fibre. Values of single and total ions transported by the wicks were compared to accumulation values reported for hyperaccumulator plants.

## 2.2 Materials and methods

Key issues considered during the experimental design to establish the parameters were:

*i)* soil solution transport from the roots to the aerial parts through the xylem capillaries and a diameter in the reported range for capillaries ( $10\text{-}200 \mu\text{m}$ ). These features were used to define the type of fibre and the pore diameter (see Table 2) and tested by using a capillary siphon (Figure 1);

*ii)* M1 allowed the setting of mobility similarities between M1 to the species reported in the phytoremediation literature, considering that cellulose is the main component of plants. The fibre composition can be seen in Table 2;



*iii*) heavy metal used in the experimental work are normally found in contaminated soils, because contamination is usually due to a mixture of heavy metals rather than to only one metal. The concentration used (1.5 mg/L) was higher than that reported for uncontaminated soil solutions (1 to 100 µg/L) (Kabata-Pendias and Pendias, 2001);

*iv*) an acidic pH (4), to ensure solubility of the metal in the solution, and a basic pH (8), to compare mobility in both conditions to that reported in the literature (see Table 1), were applied in the experiments;

*v*) performance in phytoremediation processes takes into account the heavy metal accumulation in the roots and the transport to the tops; this is why both accumulation on the material and transport in the solution were considered; they were tested by using mass balance.

### 2.2.1 Building of the capillary syphon

A capillary syphon (Figure 2.1) was built with plastic pipes (30 cm long and 0.8 cm diameter) and filled up using two small pore diameter materials (M1 and M2) as capillary means of transport (absorbent wicks). Before filling the pipes, they were washed with a nitric acid solution (10% HNO<sub>3</sub>) for 3 hours and rinsed with distilled water. Both materials were washed with distilled water for 3 hours and set to constant weight. Table 2.1 shows the weights of materials, their diameters and their composition.

Table 2.1 Properties of the tested materials for heavy metal capillary transport

Material	Weight (g)	Material pore (µm)	Wick diameter (cm)	Wick material composition
M1	2.4	20-25	0.80	Cellulose 99%
M2	1.2	20-30	0.80	Polyester 80%-polyamide 20%

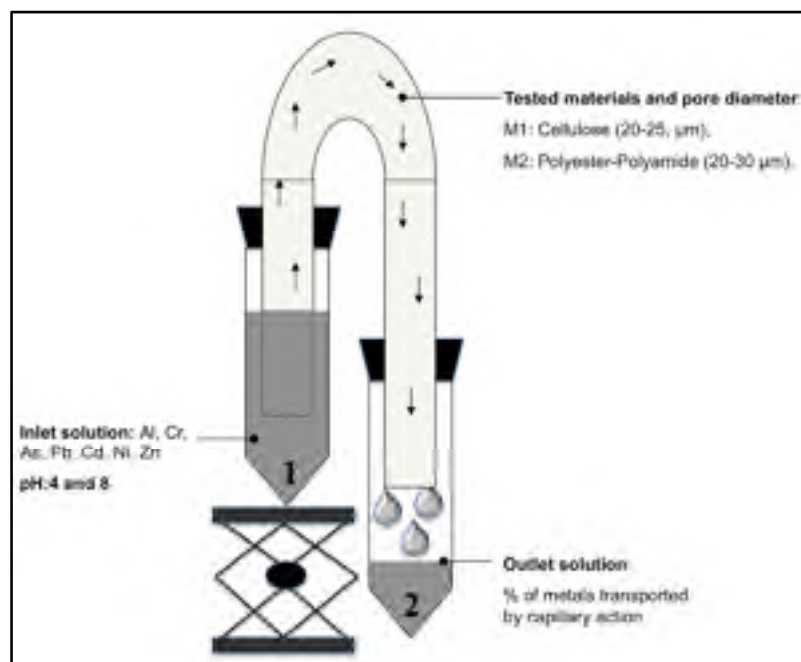

Figure 2.1 Capillary siphon

### 2.2.2 Transport of heavy metals

Metal content, transferred by capillary action through the materials, was estimated every 24 hours. Tubes 1 and 2 were changed on a daily basis, tube 1 by adding 45 mL of multi-element solution (pH 4 or 8) and tube 2 to collect the solution at the outlet (Figure 2.1). The volume of solution transported from tube 1 to 2 was measured and the metal content in the inlet tube (in the materials) and in the outlet tube were calculated by mass balance. This procedure was repeated eight times running in order to observe whether the metals were effectively transported through the materials.

A refill solution at pH 4 and another one at pH 8 were prepared from a multi-element standard solution ( $1000 \mu\text{g}\cdot\text{L}^{-1}$ ). Heavy metals in the standard solution were As (V), Al (III), Cd (II), Cr (III), Ni (II), Pb (II) and Zn (II) in 5%  $\text{HNO}_3$  and 10% HCl (SCP SCIENCE). The pH of the solutions with metals was adjusted to 4 by adding environmental grade water

(Fisher) and to 8 by adding NaOH (1 M) prepared from 97% NaOH (Anachemia). The concentration used to refill both solutions was 1.5 mg/L for each metal.

### **2.2.3 Determination of heavy metals**

Determination of the heavy metal concentration in the inlet and outlet solutions was made by ICP-OES Varian Vista MPX model. The calibration curve was obtained with a correlation coefficient of 0.99. The wavelengths ( $\lambda$ ) used for the metals were: lead,  $\lambda=220,353$  nm; nickel,  $\lambda=231,604$  nm; zinc,  $\lambda=213,857$  nm; arsenic,  $\lambda=228,812$  nm aluminum,  $\lambda=396,152$  nm; chrome,  $\lambda=267,716$  nm and cadmium,  $\lambda=226,502$  nm.

### **2.2.4 Statistical analysis**

Data obtained in this work were subjected to statistical analysis of variance (ANOVA) with the aid of JMP 8 software (SAS Institute Inc.). Differences were considered significant at  $P<0.05$  using the Student's t test. The Student's t-test is a statistical significance test used for comparing the means of two treatments based on small independent samples (Caprette, 2013). A confidence level of 95% ( $P<0.05$ ) is generally used in the field of chemical analysis (Efstathiou, 2013).

## **2.3 Results and discussion**

The work's experimental approach involved the transport of solutions with heavy metals, under acidic and basic conditions, by capillary action through the materials M1 and M2.

### **2.3.1 Volumes of solution transported by the materials**

The accumulated volumes of solution for each material are shown in Figure 2.2. In this respect, no significant differences were observed on the same material as result of the pH change. As it can be seen in the Figure 2.2-a, M1 showed practically the same volumes of

transported solutions in acidic and in basic conditions, while for M2, the transport velocity was slightly higher for the acidic conditions and, accordingly, the accumulated volume was increased a little (see Figure 2.2-b). These slight variations can be attributed to differences in the structure of the porous media. Thereby, although an average pore diameter for the materials is commonly used (see Table 2.1), usually porous media present variation in pores sizes, which are interconnected, and form a three-dimensional network system specific for each material, which modifies the flow inside these (Chatterjee and Gupta, 2002). Furthermore, densities of materials (different weight in the same volume for the wicks, see Table 2.1), as well as solutions characteristics, affect the absorption capacity of the materials.

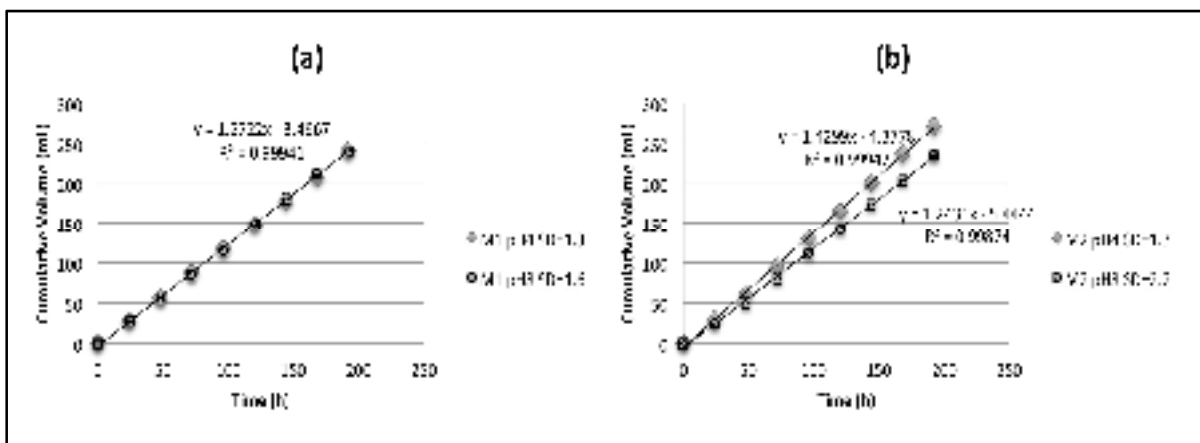

Figure 2.2 Cumulative volume of transported solution by the tested materials  $\pm$  standard deviation (SD): (a) M1 and (b) M2

### 2.3.2 Heavy metals mobility in acidic conditions

Although the accumulated volumes of solution in the outlet tube exhibited no great differences, the transport of ions did show significant dissimilarities depending on the material used, especially under acidic conditions. In general, higher ion transport rates were observed at pH=4 (Figure 2.3a and 2.3c) where metals are more soluble when compared to the basic solution (pH=8). M1 displayed an important transport of Zn, Ni, Cd and As, and a higher accumulation for certain metals such as Pb, Al and Cr (Figure 2.3a), while M2 showed a greater transport capacity for all ions, as illustrated in Figure 2.3c, and a relatively low metal accumulation potential.

In this regard, the pH value has a preponderant effect on the heavy metal adsorption on materials (Gérente *et al.*, 2000); on one hand, pH affects the metal species that coexist in solution and, on the other, it modifies the surface charge of the adsorbent materials (in this case M1 and M2) in such a way that the presence and type of functional group in the material (hydroxyl, amino, carboxyl, etc.) determines the surface charge. At low pH values, the functional groups on the surface of the materials are protonated facilitating the fixation of negatively charged molecules as a result of the electrostatic attractions which in turn allow the passage of positively charged molecules by the repulsion force (Tobin *et al.*, 1984; Vargas-Nieto *et al.*, 2011).

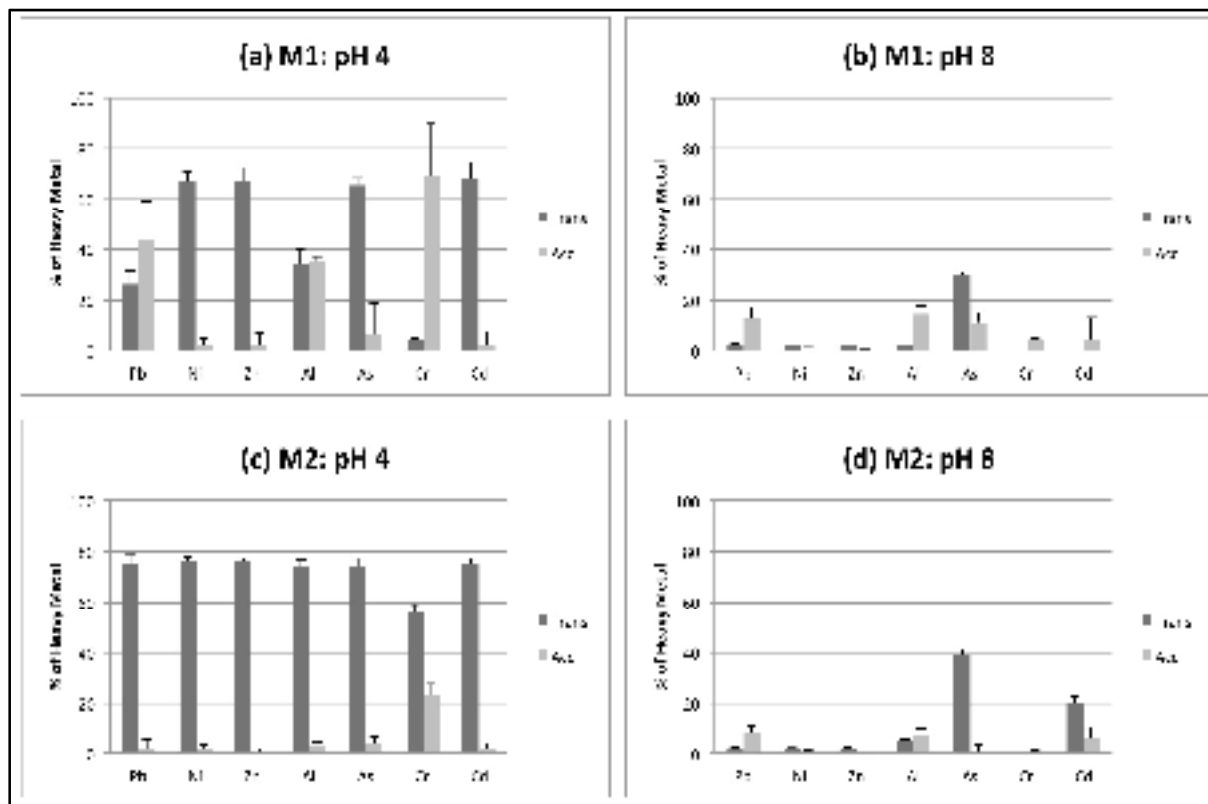

Figure 2.3 Percentage of heavy metals transported (T) and accumulated (A) by the materials: (a) in acidic conditions, (b) M1 in basic conditions, (c) M2 in acidic conditions and (d) M2 in basic conditions, bar errors represent standard deviation

Owing to the composition of the materials, M1 has a greater number of active sites when compared to M2 (Figure 2.4). Thus, at low pH, hydroxyl (-OH) and amino (-NH<sub>2</sub>) groups on the surface of the materials are highly protonated and facilitate the pass of cationic molecules (Nikiforova and Kozlov, 2010; Öztürk *et al.*, 2009; Tobin *et al.*, 1984; Vargas-Nieto *et al.*, 2011); this is the case of Zn, Ni, Cd and As, and, on the other hand metals such as Cr, Pb and Al showed affinity with M1, while M2 did not present high amounts of active sites capable to fix the same metals.

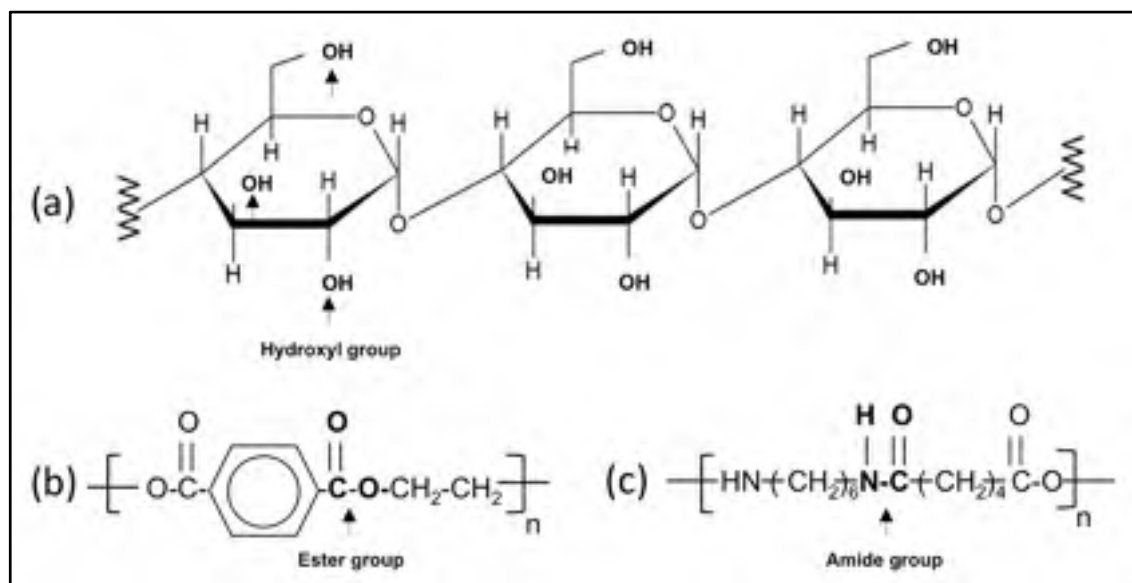
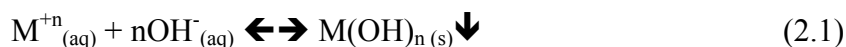

Figure 2.4 Chemical structure of (a) cellulose in M1, (b) polyester 80% and (c) polyamide 20% in M2

Similar results to those obtained in this study, concerning the accumulation of metals at low pH values, have been reported for materials with high cellulose content. Low accumulation of Cd, Zn and Ni was exhibited in papaya wood (Gérente *et al.*, 2000; Saeed *et al.*, 2005), while metals such as Pb on sugar beet pulps (Gérente *et al.*, 2000; Reddad, 2002) and Cr in maple sawdust (Yu *et al.*, 2003) and compost (Vargas-Nieto *et al.*, 2011) showed important levels of accumulation.

### 2.3.3 Heavy metals mobility in basic conditions

In the basic solution, precipitation of hydroxides has prevented the transport of heavy metals through the material; equation 2.1 shows the general chemical reaction of metal ions in alkaline conditions (Feng *et al.*, 2000).



The transport percentages observed in Figures 2.3b and 2.3d provide elements to confirm that most of the metal ions were precipitated in the inlet tube. M1 showed a very low percentage of accumulated or transported ions through the material, As was the most abundant ion found in the outlet tube with around 30% (Figure 2.3b). For M2, about 39% of As and 20% of Cd were found in the outlet tube (Figure 2.3d). As and Cd presented a high mobility in both acidic and basic conditions. In this case, the differences in the transport of As by the same material but under different conditions of pH can be attributed to the formation of aluminum hydroxides which co-precipitate with arsenic ions in the basic medium and reduce their transport under these conditions (Tremel-Schaub and Feix, 2005), while, in turn, soluble traces of cadmium can be fixed by active sites on M1.

#### **2.3.4 Comparison to hyperaccumulator plants**

Values of heavy metal content in plants considered as levels of accumulation and hyperaccumulation are presented in Table 2.2. These values were compared to those obtained for the tested materials in the present work, considering 1 kg of material. Because most of the hyperaccumulator plants are selective, criteria for defining a hyperaccumulator species are given as a function of single metals. Table 2.2 allows bringing into comparison the values of each metal transported and the sum of transport (T) and accumulation (A), as well as the total sum values (including all the metals present in the solution). In Table 2.2's last row, values highlighted in bolds indicate that the tested materials showed similar levels to those reported individually for most metals in hyperaccumulator plants. These results exhibited M2 as more efficient to transport heavy metals and M1 with a greater accumulation capacity, with important correspondence to that reported for the translocation of metals in plants.

In this way, metals transported with the greatest difficulty in M1 were Cr, Pb and Al. Comparatively, some authors have reported that Cr and Pb are the least transported by plants to their aerial parts (Adriano, 2001; Kabata-Pendias and Pendias, 2001; Lübben and Sauerbeck, 1991). On the contrary, Ni, Zn and Cd were the most easily transported by M1, similar to plants where Ni is transported with relative ease and Cd and Zn are readily



transported (Adriano, 2001; Alkorta *et al.*, 2004; Alloway and Jackson, 1991; Kabata-Pendias and Pendias, 2001).

Table 2.2 Accumulation and hyperaccumulation levels in plants compared to the estimated levels of transport (T) and to the total sum of transport and accumulation (T+A), in acidic conditions

Heavy metal	*Plant/Families of Heavy Metal Hyperaccumulators	Minimum levels of accumulation found in plants (mg·kg <sup>-1</sup> )	Hyperaccumulation levels in plants (mg·kg <sup>-1</sup> )	Estimated for 1 kg of M1 (mg·kg <sup>-1</sup> )		Estimated for 1 kg of M2 (mg·kg <sup>-1</sup> )	
				T	T+A	T	T+A
Pb	Compositae	200	>1,000	58	154	333	342
Ni	Brassicaceae	100	>1000	150	154	342	350
	Fabaceae/Leguminaceae						
Zn	Geraniaceae	500	>10,000	158	162	358	358
	Crassulaceae						
Al	Brassicaceae	100	>1,000	79	162	350	367
As	Vochysiaceae	100	>1,000	146	158	333	350
	Brassicaceae	100	>1,000	146	158	333	350
Cr	Ericaceae	100	>1,000	8	175	267	375
	Labiatae						
	Geraniaceae						
	Asteraceae						
	Brassicaceae						
	Convolvulaceae						
Cd	Gerinaceae	10	>100	158	162	358	367
	Leguminosae/Fabaceae						
	Chenopodiaceae						
Total	Asteraceae	10	>100	158	162	358	367
	Brassicaceae						
				757	1,127	2,341	2,509

On the other hand, it must be taken into account that the life cycle of plants allow the introduction of heavy metals in the food chain or their reintroduction to the soil once the contaminated plant perishes. Because in phytoextraction processes it is not considered if the metal is adsorbed on the cell walls surface or within the cells, desorption and recovery of heavy metals directly from the plants is not guaranteed (Olguin and Sanchez-Galvan, 2012). Thus, when plants are harvested and removed from the site, the accumulation of huge volumes of hazardous biomass becomes a problem. Phytoremediation wastes must be treated and disposed; some alternatives for their treatment are composting and compaction, combustion and gasification, and pyrolysis (Ghosh and Singh, 2005). However, treatment of

the formed leachate, CO<sub>2</sub> emission and heavy metals recovery from leachate or from ashes, as results of these processes, must be considered also in the cost-benefit balance.

### **2.3.5 Heavy metals mobility and pH in soils**

As a general rule, mobility of heavy metals in soils is strongly related to pH conditions. Usually, acidic pH allows the mobilization of metals, while basic pH reduces the solubility of metals and, in consequence, their mobilization. Using a qualitative scale for the mobility of metals in soils at pH 4, the following behavior can be stated: Cd has strong mobility, Ni and Zn have medium mobility and Pb, Cr and Al have weak mobility (Kabata-Pendias and Pendias, 2001). Cd is reported as a very mobile metal in soils and readily available for plants, while Pb has low water solubility, which is why this metal turns out to be very immobile in soils (Miclean *et al.*, 2000). In this sense, M1 displayed a great similarity to the described behavior.

Some of these elements can be found in the soil presenting different oxidation states such as Cr (III and VI) and As (III and V). In other cases, the metal has an oxidation state as Cd (II), Ni (II), Pb (II), Zn (II), and Al (III) (Tremel-Schaub and Feix, 2005). However, different chemical species of the same metal can co-exist under the same conditions of pH (Feng *et al.*, 2000). Because the present study was focused solely in determining the metal ion transport through the materials, speciation studies were not performed. However, subsequent work may consider the elements speciation and the mobility of each chemical species through the materials.

So far, most of the environmental regulation in soil pollution sets maximum total limits for each metal. These criteria are strongly questioned by some authors that consider that the chemical species must be known in order to establish more safe limits depending on the toxicity of each species (Hsiu-Chuam *et al.*, 2006). Nevertheless, numerous studies suggest that the interaction of many environmental variables can change the mobility of metals in soils (Chojnacka *et al.*, 2005; Ernst, 1996; Violante *et al.*, 2010). In this sense, it could be

safer to reduce the total concentration of toxic metals in soils, bringing along a risk minimization for particular elements that can change their oxidation state and become a threat for the environment and public health.

Finally, an important aspect to be studied in future research avenues is the possibility of testing layered double hydroxide-type structures (LDH) in basic pH. These materials are composed of layers with a positive charge, which permit the formation of interlayer anions to balance the load between the layers. Because fibres are layered materials that also exhibit weak positive charges, this must be considered to obtain similar compounds using the methodology followed in this work. Such composites are currently being applied in water treatment for removing organic and inorganic contaminants used by industrial and biomedical sciences to exchange capacity (Zümreoglu-Karan and Nadim, 2012; Dumas, *et al.*, 2012).

## **2.4 Conclusions**

The tested materials showed to be effective in the transport of heavy metals by capillary action; these materials allowed the transport of several metals at the same time. The best performance for the ions transport was observed under acidic conditions for M2, while M1 showed important similarities to the reported for heavy metals in soil and plants. It should be remarked, from an environmental point of view, that M1 is composed of cellulose, the most abundant biomolecule on Earth, while M2 is a synthetic not biodegradable material.

In general, nickel, zinc and cadmium were the metals the most easily transported in both materials. Minimal amounts of Cr, Pb and Al were transported by M1 due to their affinity for the material, whereas M2 displayed a higher capacity to transport the same ions. Both materials transported arsenic at pH 4 and 8 and M2 also showed a slight transport of cadmium in basic conditions.

The quantities transported of metal ions at pH 4, in ascending order, were:

- M1: Cr < Pb < Al < As < Ni = Zn = Cd
- M2: Cr < Al = Pb = As < Ni = Zn = Cd

Transport of heavy metals from the roots to the aerial parts of plants is a key factor in phytoextraction processes because the pollutant may be removed from the site once the plants are harvested. In this context, the transport of heavy metals through materials with a similar diameter to those found in the plants xylem may be of practical use in the development of new techniques to remove these pollutants based on the capillary properties showed by certain materials, replicating the soil-plant-atmosphere continuity (Sperry *et al.*, 2003). Under these premises, research must be carried out to learn more about the performance of the materials, particularly, in relation to the change of certain environmental variables (concentrations, temperature, pressure, type of contaminants, etc.) and, in turn, applications *in situ* should also be undertaken. Given the wide range of micro and nanomaterials (properties, life spans, costs, etc.) and the changing conditions of the contaminated sites, the emulation of transport of pollutants based on the vascular system of plants may have an interesting potential of development in soil remediation.

## Acknowledgments

The authors wish to thank Mrs. Mirela Sona for technical assistance in the ICP-OES analysis.

## 2.5 References

- Adriano, D. C. (2001). *Trace elements in Terrestrial Environments. Biogeochemistry, Bioavailability and Risks of Metals*. Second ed., Springer-Verlag, New York, p. 867.
- Alkorta, I., Hernandez-Allica, J., Garbisu, C. (2004). *Plants Against the Global Epidemic of Arsenic Poisoning*. *Environment International* 30(7), 949-951.
- Alloway, B. J., Jackson, A. P. (1991). *The Behaviour of Heavy metals in Sewage Sludge-Amended Soils*. *Science of the Total Environment* 100, 151-176.

- Barceló, J., Poschenrieder, C. (2003). *Phytoremediation: Principles and Perspectives*. Contributions to Science 2(3), 333-344.
- Belluck, D. A., Benjamin, S. L., David S. (2006). *Why Remediate?* In: G. Echevarria, N. Goncharova, J. L. Morel (Eds.), *Phytoremediation of Metal-contaminated Soils*. Springer-Verlag, Dordrecht, p. 1-23.
- Blais, J. F., Meunier, N., Mercier, G. (2010). *New Technologies for Toxic Metals Removal from Contaminated Sites*. Recent Patents on Engineering 4(1), 1-6.
- Bourrelrier, P. H., Berthelin, J. (1998). *Contamination des sols par les éléments en traces: Les risques et leur gestion*. Academie des sciences, Paris, p. 438.
- Campbell, N. A., Reece, J. B. (2004). *Biology*. Seventh ed., Benjamin Cummings, Brussels, p. 1482.
- Caprette, D. R. (2013). *Student's t Test for Independent Samples*. Experimental Biosciences, Rice University. Resources for Introductory and Intermediate Level Laboratory Courses. <http://www.ruf.rice.edu/~bioslabs/tools/stats/ttest.html>. Accessed May 15, 2013.
- Chatterjee, P. K., Gupta, B. S. (2002). *Absorbent Technology*. First ed., Elsevier Amsterdam, Boston, London, New York, Oxford, Paris, p. 501.
- Chojnacka, K., Chojnacki, A., Górecka, H., Górecki, H. (2005). *Bioavailability of Heavy Metals from Polluted Soils to Plants*. Science of the Total Environment 337 (1-3), 175-182.
- De Boer, A. H., Volkov, V. (2003). *Logistics of Water and Salt Transport Through the Plant: Structure and Functioning of Xylem*. Plant, Cell & Environment 26(1), 87-101.
- Dermont, G., Bergeron, M., Mercier, G., Laflèche-Richer, M. (2008). *Metal-Contaminated Soils: Remediation Practices and Treatment Technologies*. Practice Periodical of Hazardous, Toxic and Radioactive Waste Management 12(3), 188-209.
- Dumas, E., Laforest, V., De Roy, M., Forano, C., Bourgois, J. (2012). *PCB Adsorption by Organomodified LDH Phases*. Proceedings of the Water, Wastes and Sustainable Development Seminar, Agadir, Morocco, March 21-24, 2012. (Adsorption de PCB par des Phases HDL Organomodifiées. Colloque Eau, Déchets et Développement Durable, Agadir, Maroc, 21-24 mars 2012.)
- Efstathiou, C. E. (2013). *Student's t-Test: Comparison fo two means*. Department of Chemistry, University of Athens.<http://www.chem.uoa.gr/applets/AppletTtest/AppletTtest2.html>. Accessed May 15, 2013.

- Environment Canada (2003). *Phytorem - Potential Green Solutions for Metal Contaminated Sites*. <http://www.ec.gc.ca/Publications/default.asp?lang=En&xml=B8A7B13F-FF7B-4375-BBAF-2DE33346C127>. Accessed June 11, 2011.
- Ernst, W. H. (1996). *Bioavailability of Heavy Metals and Decontamination of Soils by Plants*. Applied Geochemistry 11(1-2), 163-167.
- Feng, D., Aldrich, C., Tan, H. (2000). *Treatment of Acid Mine Water by Use of Heavy Metal Precipitation and Ion Exchange*. Minerals Engineering 13(6), 623-642.
- Fritioff, A., Greger, M. (2003). *Aquatic and Terrestrial Plant Species with Potential to Remove Heavy Metals from Stormwater*. International Journal of Phytoremediation 5(3), 211-224.
- Garbisu, C., Alkorta, I. (2001). *Phytoextraction: a Cost-Effective Plant-Based Technology for the Removal of Metals from the Environment*. Bioresource Technology 77(3), 229-236.
- Gérente, C., Couespel du Mesnil, P., Andrès, Y., Thibault, J.-F., Le Cloirec, P. (2000). *Removal of Metal Ions from Aqueous Solution on Low Cost Natural Polysaccharides. Sorption Mechanisms Approach*. Reactive and Functional Polymers 46(2), 135-144.
- Ghorbani, H. (2008). *Factors Controlling the Bioavailability of Potentially Harmful Metals in Wastewater Treated Soils*. Proceedings of the International Meeting on Soil Fertility Land Management and Agroclimatology, Kusadasi, Turkey, October 29-31, 2008, p. 987-996.
- Ghosh, M., Singh, S. P. (2005b). *A Review on Phytoremediation of Heavy Metals and Utilization of It's by Products*. Asian Journal on Energy and Environment 6(4), 214-231.
- Girard, M. C., Walter, J. C., Berthelin, J., Morel, J. L. (2005). *Soils and Environment: Course, Exercices and Case Studies* (Sols et Environnement : Cours, Exercices et Études de Cas). First ed., Dunod, Paris, p. 816.
- Gisbert, C., Almela, C., Velez, D., Lopez-Moya, J. R., de Haro, A., Serrano, R., Montoro, R., Navarro-Avino, J. (2008). *Identification of as Accumulation Plant Species Growing on Highly Contaminated Soils*. International Journal of Phytoremediation 10(3), 185-196.
- Guo, Z., Cao, Y. (2005). *Experimental Studies of Biliquid Capillary Siphons*. Chemical Engineering Science 60(10), 2621-2626.
- Hacke, U. G., Sperry, J. S., Wheeler, J. K., Castro, L. (2006). *Scaling of Angiosperm Xylem Structure with Safety and Efficiency*. Tree Physiology 26(6), 689-701.

- Harper, J. L. (1977). *Population Biology of Plants*. First ed., Academic Press, New York, p. 900.
- He, Z. L. L., Yang, X. E., Stoffella, P. J. (2005). *Trace Elements in Agroecosystems and Impacts on the Environment*. *Journal of Trace Elements in Medicine and Biology* 19(2-3), 125-140.
- Hsiu-Chuan, V., C., M.-T., Yuen-Yi, T., Kung-Lin, O. (2006). *Assessment of Heavy Metal Bioavailability in Contaminated Sediments and Soils Using Green Fluorescent Protein-based Bacterial Biosensors*. *Environmental Pollution* 142(1), 17-23.
- Kabata-Pendias, A., Pendias, H. (2001). *Trace Elements in Soils and Plants*. Third ed., CRC Press, Boca Raton, London, New York, Washington DC, p. 403.
- Kashem, M. A., Singh, B. R. (2002). *The effect of Fertilizer Additions on the Solubility and Plant-availability of Cd, Ni and Zn in Soil*. *Nutrient Cycling in Agroecosystems* 62(3), 287-296.
- Kvesitadze, G., Khatishashvili, G., Sadunishvili, T., Ramsden, J. (2006). *Biochemical Mechanisms of Detoxification in Higher Plants: Basis of Phytoremediation*. First ed., Springer-Verlag, Berlin Heidelberg, p. 262.
- Lstiburek, J. W. (2007). *Capillary Suction Small Sacrifices*. *American Society of Heating, Refrigeration and Air-Conditioning Engineers Journal* 49(7), 58-61.
- Lübben, S., Sauerbeck, D. (1991). *The Uptake and Distribution of Heavy Metals by Spring Wheat*. *Water, Air and Soil Pollution* 57-58(1), 239-247.
- McGrath, S. P., Zhao, F. J., Lombi, E. (2002). *Phytoremediation of Heavy Metals, Metalloids and Radionuclides*. *Advanced in Agronomy* 75, 1-56.
- Miclean, M., Roman, C., Levei, E., Senila, M., Abrahm, B., Cordos, E. (2000). *Heavy Metals Availability for Plants in Mining Area from North-Western Romania*. *Proceedings of the 15th International Congress of the International Soil Conservation Organization*. Budapest, May 18-23, 2008, p. 340.
- Miranda, L. R., Gomes, L. M., Fernandes, G., Velho, L., Cotta, M., Rossatto, D., Haridasan, M., Franco, C. (2011). *Al-Hyperaccumulator Vochysiaceae from the Brazilian Cerrado Store Aluminum in Their Chloroplasts Without Apparent Damage*. *Environmental and Experimental Botany* 70(1), 37-42.
- Nijsee, J. (2004). *On the Mechanism of Xylem Vessel Length Regulation*. *Plant Physiology* 134(1), 32-34.

- Nikiforova, T. E., Kozlov, V. A. (2010). *Specific Features of Sorption of Heavy Metal Ions by Cellulose-Containing Sorbent from Aqueous Media*. Russian Journal of Applied Chemistry 83(10), 1781-1784.
- Öztürk, H. B., Vu-Manh, H., Bechtold, T. (2009). *Interaction of Cellulose with Alkali Metal Ions and Complexed Heavy Metals*. Lenzinger Berichte 87, 142-150.
- Padmavathiamma, P. K., Li, L. Y. (2007). *Phytoremediation Technology: Hyper-Accumulation Metals in Plants*. Water Air and Soil Pollution 184(1-4), 105-126.
- Pilon-Smits, E., Freeman, J. (2006). *Environmental Cleanup Using Plants: Biotechnological Advances and Ecological Considerations*. Frontiers in Ecology and the Environment 4(4), 203-201.
- Rachou, J., Sauvé, S. (2008). *Evaluation of Affinity Constants of Cu, Cd, Ca and H for Active Soil Surfaces for a Solid Phase-Controlled Soil Ligand Model*. Environmental Chemistry 5(2), 1448-2517.
- Reddad, Z., Gérente, C., Andres, Y., Le Cloirec, P. (2002). *Adsorption of Several Metal Ions onto a Low-Cost Biosorbent Kinetic and Equilibrium Studies*. Environmental Science & Technology 36(9), 2067-2073.
- Saeed, A., Akhter, W., Iqbal, M. (2005). *Removal and Recovery of Heavy Metals from Aqueous Solution Using Papaya Wood as a New Biosorbent*. Separation and Purification Technology 45(1), 25-31.
- Shah, F., Ahmad, N., Masood, K., Peralta-Videa, J., Ahmad, F. (2010). *Heavy Metal Toxicity in Plants*. In: M. Ashraf, M. Ozturk, M. S. A. Ahmad (Eds.), Plant Adaptation and Phytoremediation. Springer-Verlag, New York, p. 71-97.
- Sheoran, V., Sheoran, A. S., Poonia, P. (2011). *Role of Hyperaccumulators in Phytoextraction of Metals From Contaminated Mining Sites: A Review*. Critical Reviews in Environmental Science and Technology 41(2), 168-214.
- Singh, R., Dhanial, G., Sharma, A., Jaiwal, P. (2007). *Biotechnological Approaches to Improve Phytoremediation Efficiency for Environment Contaminants*. In: S. N. Singh, R. D. Tripathi (Eds.), Environmental Bioremediation Technologies. Springer-Verlag, Berlin, p. 223-258.
- Sinha, R., Sunil, H., Tandon, P. (2007). *Phytoremediation: Role of Plants in Contaminated Site Management*. In: S. S. Singh, R. D. Tripathy (Eds.), Environmental Bioremediation Technologies. Springer-Verlag, Berlin, p. 315-330.



- Sperry, J., Volker, S., Uwe, G. H. (2003). *Xylem Hydraulics and the Soil-Plant-Atmosphere Continuum: Opportunities and Unresolved Issues*. *Agronomy Journal* 95(1), 1362-1370.
- Sun, L., Niu, Z., Sun, T. (2007). *Effects of Amendments of N, P, Fe on Phytoextraction of Cd, Pb, Cu, and Zn in Soil of Zhangshi by Mustard, Cabbage, and Sugar Beet*. *Environmental Toxicology* 22(6), 565-571.
- Tobin, J. M., Cooper, D. G., Neufeld, R. J. (1984). *Uptake of Metal Ions by Rhizopus arrhizus Biomass*. *Applied and Environmental Microbiology* 47(4), 821-824.
- Tremel-Schaub, A., Feix, I. (2005). *Soil Contamination. Transfert from Soils to Plants (Contamination des Sols. Transferts des Sols vers les Plantes)*. First ed., EDP Sciences-ADEME Editions, Les Ulis-Angers, p. 413.
- United Nations Environment Programme and Agency for the Environment and Energy Management (UNEP and ADEME). (2006). *Identification and Management of Contaminated Sites. A Methodological Guide*. First ed., ADEME Editions, Paris, p. 117.
- Vargas-Nieto, C., Carrizao, J. G., Castillo, E. (2011). *A Study of Low-cost Adsorbent Materials for Removing Cr(VI) from Aqueous Waste Effluent*. *Ingeniería e Investigación* 31(1), 154-162.
- Violante, A., Cozzolino, V., Perelomov, L., Caporale, A. G., Pigna, M. (2010). *Mobility and Bioavailability of Heavy Metals and Metalloids in Soil Environments*. *Journal of Soil Science and Plant Nutrition* 10(3), 268-292.
- Wu, J., Hsu, C., Cunningham, S. D. (1999). *Chelate-Assisted Pb Phytoextraction Pb Availability Uptake, and Translocation Constraints*. *Environmental Science Technology* 33(11), 1898-1904.
- Yu, L. J., Shukla, S. S., Dorris, K. L., Shulka, A., Margrave, L. S. (2003). *Adsorption of Chromium from Aqueous Solutions by Maple Sawdust*. *Journal of Hazardous Materials B* 100(1-3), 53-63.
- Zümreoglu-Karan, B., Nedim, A. (2012). *Layered Double Hydroxides-Multifunctional Nanomaterials*. *Chemical Papers* 66(1), 1-10.



## CHAPTER 3

### HEAVY METAL TRANSPORT AS AN ANALOGY TO THE TRANSPIRATION PHENOMENON IN VASCULAR PLANTS

<sup>a</sup>Norma Oropeza, <sup>b</sup>Robert Hausler, <sup>c</sup>Mathias Glaus, <sup>d</sup>Ricardo Vega, <sup>e</sup>Rabindranarth Romero

<sup>a, b, c, d</sup> Station expérimentale des procédés pilotes en environnement, École de technologie supérieure, Université du Québec, Canada, 1100, rue Notre-Dame Ouest, H3C 1K3, Montréal, Québec, Canada.

<sup>e</sup>Universidad Veracruzana, Facultad de Ingeniería Civil, Lomas del Estadio s/n 91000, Zona Universitaria, Xalapa, Veracruz, México.

This article was submitted for publication in the Journal of Applied Research and Technology; On date: 2013-02-15; Manuscript confirmation: 735

#### **Abstract**

Heavy metal pollution in soils is a growing concern of our times because of the high capability of these metals to enter the food chain. In vascular plants, capillary action and transpiration allow the transport of soil solution through the xylem vessels (10-200  $\mu\text{m}$ ), which results in the translocation of toxic metals into the aerial parts of plants. Currently, this ability of vegetables is applied and exploited by phytoremediation technologies. Making an analogy to the transpiration phenomenon, this work aimed at evaluating the transport of heavy metals (Pb, Ni, Zn, Al, As, Cr and Cd) using two small diameter materials (20-30  $\mu\text{m}$ ; M1 and M2) under different suction pressures with two solutions (pH 4 and 8). Determination of the metal concentration in the solutions was performed by means of Inductively Coupled Plasma. Results showed an effective transport of Ni, Cd, Zn and As under acidic conditions for both materials; similar outcomes have also been reported for the mobility of metals in soils. When the tested materials were subjected to pressure variations, the rate of flow of the solution increased with the pressure, but the concentration of metal

ions did not show significant changes, which is comparable to the behavior reported for membranes.

**Keywords:** heavy metals, transpiration pressure, capillary transport, hyperaccumulator plants, soil solution

### 3.1 Introduction

Soil and water pollution with heavy metals is a growing concern in the world because of the risks associated to their mobility and bioaccumulation. Lead (Pb), arsenic (As), chromium (Cr), copper (Cu), nickel (Ni) and zinc (Zn) are the most commonly found toxic metals with a long residence time in polluted sites (Anawar *et al.*, 2008; Blais *et al.*, 2010; Jarup, 2003).

In soils, mobility and bioavailability of heavy metals is strongly correlated to pH (Table 3.1), this factor is very important for the soil-plant metal transfer. Usually, a low pH facilitates the metal uptake by plants (Fritioff and Greger, 2003; Ghorbani, 2008; Kabata-Pendias and Pendias, 2001; Tremel-Schaub and Feix, 2005; Peijnenburg, 2004). The content of heavy metal in the soil solution of non-polluted soils ranges from 1 to 100  $\mu\text{g}\cdot\text{L}^{-1}$ ; accordingly, these values can be much higher in contaminated sites (Kabata-Pendias, 2004).

The pollutant, which is bioavailable for plants in the aqueous phase of the soil (Krishnamurti and Naidu, 2007; Ying *et al.*, 2002), reaches the roots by mass flow and diffusion phenomena (Tremel-Schaub and Feix, 2005) and passes through the root. From there, the soil solution rises through the xylem by capillary action and transpiration phenomenon, the latter of which is created by the pressure gradient between the root and the leaves (Campbell and Reece, 2004; Nijsee, 2004) that produces a suction effect, which allows the transport of solution in the vessels of the xylem (10-200  $\mu\text{m}$  diameter) of vascular plants (Sperry *et al.*, 2003).

Table 3.1 Transfer of heavy metals from soil to plants  
Adapted from \*USDA (1998, p. 2) and \*\*Tremel-Schaub and Feix (2005, p. 57-64)

Soil type	*pH of soil	**Transfer of metals to plants			
		Very low	Low	Medium	High
Extremely acid	3.5-4.4			Ni, Pb, Cr,	Zn,
Very strongly acid	4.5-5.0			As	Cd, Al
Strongly acid	5.1-5.5				
Moderately acid	5.6-6.0				
Slightly acidic	6.1-6.5				
Neutral	6.6-7.3	Cr, Ni	Pb, Cd,		
Slightly alkaline	7.4-7.8		As		
Moderately alkaline	7.9-8.4				
Strongly alkaline	8.5-9.0				

### 3.1.1 Pressure gradient in the xylem

By applying the Poiseuille equation (Eq. 3.1), the pressure gradient for the transport of water in the xylem vessels, calculated for trees, is about  $-0.02 \text{ MPa}\cdot\text{m}^{-1}$ , considering  $40 \text{ }\mu\text{m}$  for the vessel radius in the xylem and  $0.004 \text{ m}\cdot\text{s}^{-1}$  of transport velocity (Taiz and Zeiger, 2010). Under this suction pressure, the soil solution is transported from the soil to the plant leaves (Figure 3.1a). In this regard, some authors have exposed the similarities between the hydraulic behavior of the xylem and that of soils, which can be interpreted as the soil extension through the xylem enabling the continuity of the soil-plant-atmosphere system (Sperry *et al.*, 2003).

$$\text{Hydraulic flow} = \pi r^2 \cdot v = \left(\frac{\pi r^4}{8\eta}\right) \left(\frac{\Delta\psi_p}{x}\right) \quad (3.1)$$

Where:  $v$  = rate of flow ( $\text{m}\cdot\text{s}^{-1}$ ),  $r$  = vessel radius (m),  $\eta$  = dynamic viscosity ( $\text{Pa}\cdot\text{s}$ ) and  $\left(\frac{\Delta\psi_p}{x}\right)$  = pressure gradient ( $\text{Pa}\cdot\text{m}^{-1}$ ).

### 3.1.2 Metal hyperaccumulator plants

Depending on the species and the environmental conditions, some plants are able to take up considerable amounts of metals in their different aerial parts, such as leaves, stems, fruits and seeds (Cunningham *et al.*, 1995; Glick, 2003; Krämer, 2005; Singh *et al.*, 2007). Plants classified as hyperaccumulators are capable to transport and accumulate in their tissues amounts of a single heavy metal between 10 to 100 times more than those tolerated by crop plants (Kirkham, 2006; Kukier *et al.*, 2004).

The rates of transport of hyperaccumulator plants are a key factor in the implementation of plant-based methods for soil remediation allowing the removal of the contaminant from the site by harvesting the aerial parts of the plant. However, this type of species has certain disadvantages, such as slow growth, small biomass production, selective extraction, species that only can be used in their natural habitat among others (Kammev and Van der Lelie, 2000).

In this context, the main objective of this study was the assessment of heavy metals transport from aqueous solutions at pH 4 and pH 8 using materials with pore diameter size in the range of xylem vessels at different suction pressures. The results were compared to reported values for hyperaccumulator plants to contrast the performances.

## 3.2 Materials and methods

### 3.2.1 Capillary means of transport

Plastic pipes (30 cm long and 0.8 cm diameter) were filled with M1 and M2 as a means of transport (see Table 3.2). Before being packed with the transport materials, pipes were washed for three hours with a solution of 10% HNO<sub>3</sub> and rinsed with distilled water. The tested materials (M1 and M2) were washed with distilled water and brought to constant weight.

### **3.2.2 Heavy metal solutions**

The solutions at pH 4 and pH 8 containing As, Al, Cd, Cr, Ni, Pb and Zn were prepared by adding 1.5 mL of SCP SCIENCE multi-element standard solution ( $1000 \mu\text{g}\cdot\text{L}^{-1}$ , 5%  $\text{HNO}_3$  and 10% HCl) in 1 L of distilled water.

The solution at pH 4 was adjusted by adding Fisher environmental grade water. The solution at pH 8 was adjusted with environmental grade water and by adding 1M NaOH solution (97% NaOH, Anachemia).

### **3.2.3 Assessed pressures**

The suction pressure estimated in trees for rising the soil solution 1 m is about 0.02 MPa. Considering that, a proportional pressure was taken in the experiment to create a similar effect to that of the transpiration phenomenon in the xylem of vascular plants, that is 0.0067 MPa for a 30 cm displacement of the solutions containing the metal ions. Other pressures were also tested to assess their effect in the transport of metal ions (Table 3.2). The arrangement used for the experiments is displayed in Figure 3.1b.

A volume of 250 mL of solutions at pH 4 and pH 8 were suctioned for evaluating the transport of metal ions, using different suction pressures in M1 and M2 (Figure 3.1b), and the concentration of heavy metals was determined in the inlet and outlet solutions. The estimation of transported and accumulated metals in the tested materials was obtained by material balance.

Table 3.2 Characteristics of the tested materials at negative pressure values

Material	Weight (g)	Material pore diameter ( $\mu\text{m}$ )	Wick diameter (cm)	Wick material composition	Negative Pressure ( $\text{MPa}\cdot\text{m}^{-1}$ )
M1	2.6	20-25	0.80	Cellulose 99%	0.022, 0.045, 0.090, 0.18
M2	1.7	20-30	0.80	Polyester 80%-polyamide 20%	0.011, 0.022, 0.045

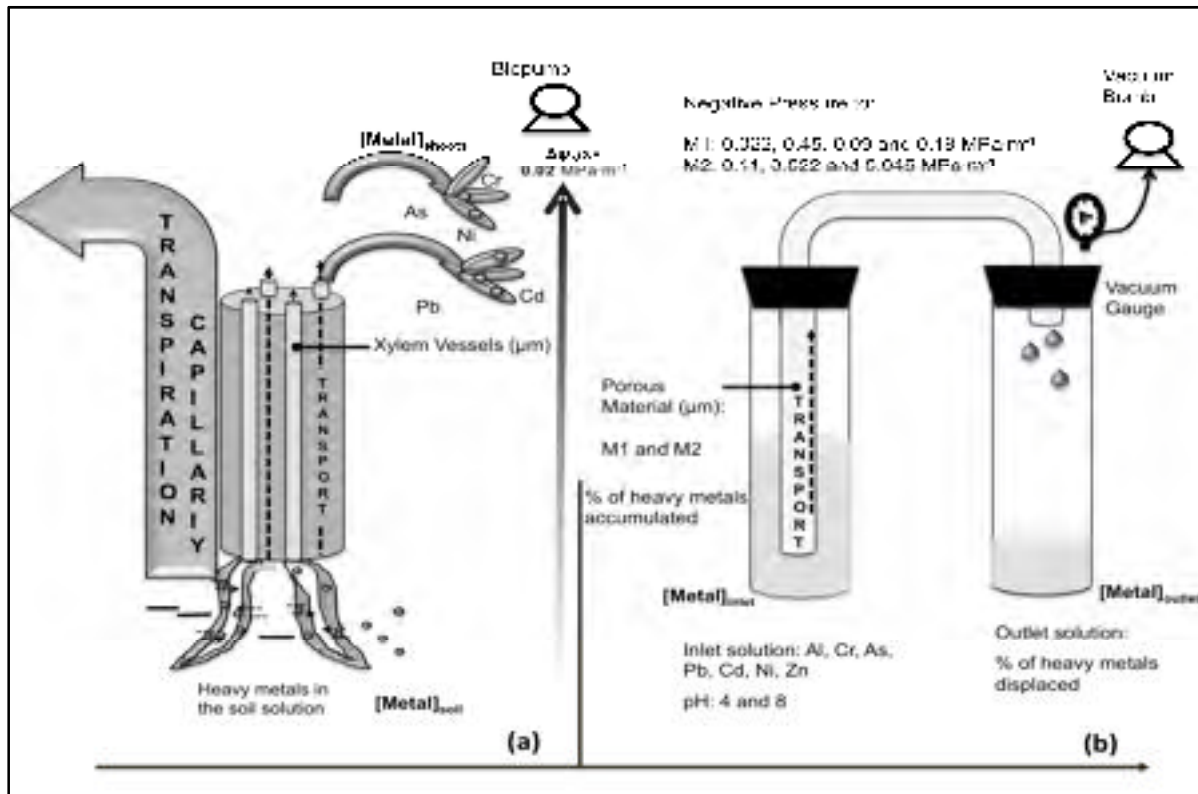

Figure 3.1 (a) Transport of soil solution in vascular plants and (b) experimental arrangement



### 3.2.4 Determination of heavy metals

The concentration of heavy metals in the inlet and outlet solutions was measured by ICP OES Varian Vista MPX model. The calibration curve fit was obtained with a 0.99 correlation coefficient. The wavelengths used are presented in Table 3.3.

Table 3.3 Wavelengths used for metal determination

<b>Metal</b>	<b>Pb</b>	<b>Ni</b>	<b>Zn</b>	<b>As</b>	<b>Al</b>	<b>Cr</b>	<b>Cd</b>
Wavelengths ( $\lambda$ , nm)	220,353	231,604	213,857	228,812	396,152	267,716	226,502

### 3.2.5 Statistical analysis

Data, obtained in triplicate ( $n=3$ ), were subjected to ANOVA analysis. Differences between treatments were tested by comparison of means (LSD-test). Measures were considered significantly different if  $P < 0.05$ . Statistical analysis was performed using the statistical software JMP8 (SAS Institute Inc.).

## 3.3 Results and discussion

The objective of the present work was to evaluate the transport of metal ions from solutions at pH 4 and pH 8 through M1 and M2, materials with diameter size in the range of those of xylem vessels, under different suction pressures based on an analogy to the transport of soil solution in the vessels of vascular plants by means of the transpiration phenomenon.

### 3.3.1 Effect of pH on the transport of heavy metals

In general, metal ions exhibited greater mobility in the acidic solution, which is reflected in the high percentage of metals recovered in the outlet solution.

M1 transported about 80% of Ni, Zn, Cd and As, 47% of Cr, while the obtained percentages for Al and Pb did not exceed 10% (Figure 3.2a). M2 showed a similar trend, however, this material allowed the transport of most metal ions with around 80% of Pb, Ni, Zn, Cr, Cd and As, and 70% of Al (Figure 3.2b). As displayed in Figure 3.2, percentage of metal ions in the outlet solution did not show a significant increase when vacuum pressure was raised.

The lower accumulation of metal ions under acidic conditions may be attributed, on one hand, to the solubility of the species in the solution, and on the other, to the protonation of active sites (hydroxy, amino, amide) found on the surface of the material, which causes competition between  $H^+$  and  $M^+$  for the occupation of these sites. Regarding M1, similar results, related to significant rates of Cr and Pb fixation, have been reported for materials with high cellulose content in acidic conditions (Gérente *et al.*, 2000; Reddad *et al.*, 2000; Vargas-Nieto *et al.*, 2011; Yu *et al.*, 2003).

In turn, as pH increases, the concentration of  $H^+$  ions in solution drops. In this manner, the competition between  $H^+$  and  $M^+$  decreases allowing an electrostatic attraction between the metallic ion positively charged and the active sites. Another important factor is the formation of metal hydroxides, which can result in steric hindrance and reduce the mobility. Thus, the differences in the transport of metal ions between M1 and M2 at the same pH conditions can be attributed to differences in their chemical composition, as a consequence of the greater amounts of active sites onto M1 (Gérente *et al.*, 2000; Saeed *et al.*, 2005).

As and Cd are elements that display high mobility in acidic and basic conditions. In this case, the differences in the transport of arsenic by the same material, but under different conditions of pH, can be attributed to the formation of aluminum hydroxides that co-precipitate with arsenic ions and reduce the transport in the basic medium (Tremel-Schaub and Feix, 2005), while soluble traces of cadmium can be fixed by the active sites on M1.

The passage of the basic solution through M1 allowed the displacement of 30% of As and 8% of Ni. For other ions, the transport was less than 3% (Figure 3.2c). M2 transported ions in the following decreasing order: 52% of As, 37% of Cd, 17% of Ni, 6% of Zn, 5% of Pb, 4% of Al and the percentage of Cr did not exceed 1% in the outlet solution (Figure 3.2d). Figure 3.2 shows the percentages of each metal found in the outlet solution. As it will be mentioned above, in general, the outlet percentages for most of the metals did not increase significantly with the rise of the pressure.

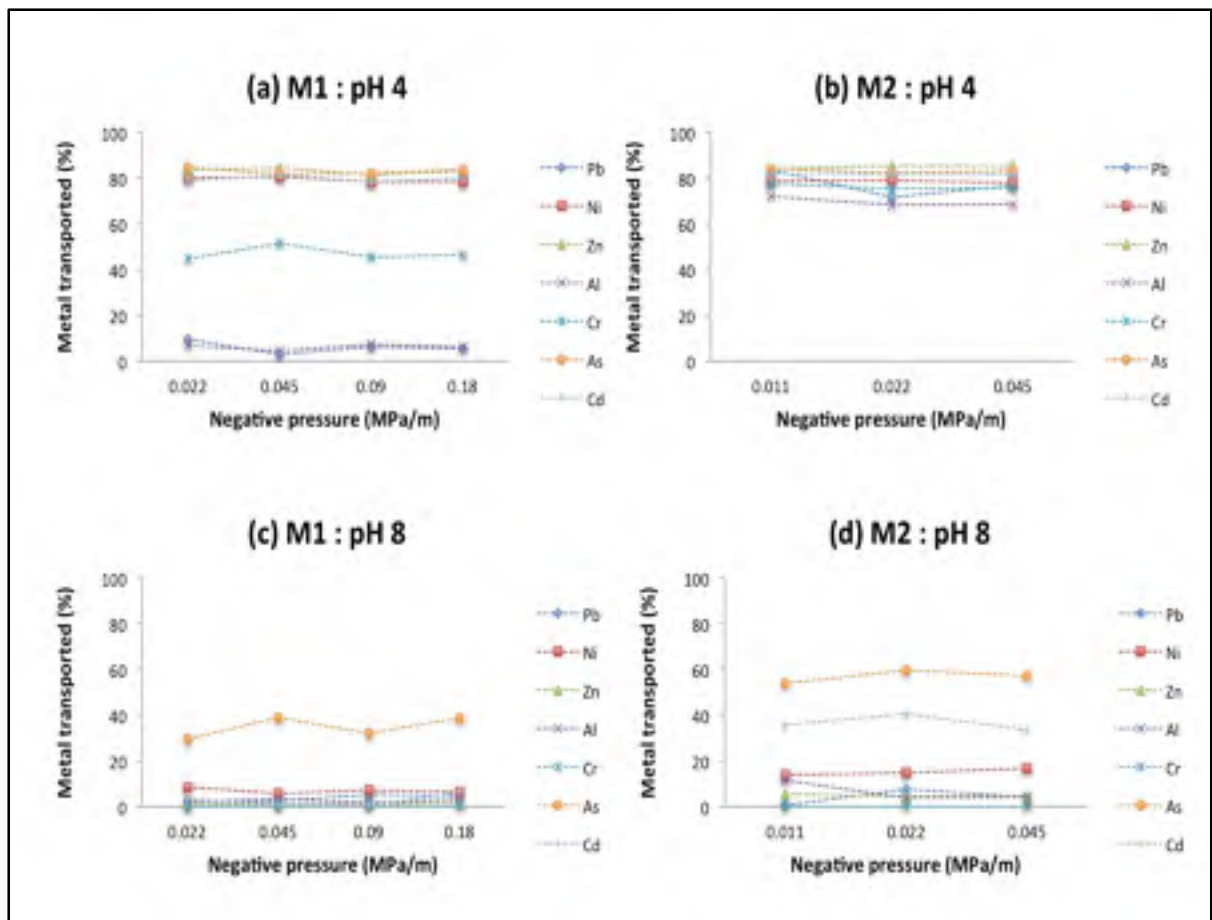

Figure 3.2 Percentage of heavy metals transported by the tested materials: (a) M1 and (b) M2 at acidic conditions and (c) M1 and (d) M2 under alkaline conditions

### 3.3.2 Pressure effect

Under suction pressure, the tested materials exhibited similar behavior to that described for membranes. Although, the rate of flow of the solution increased positively with the pressure, the transport of metal ions did not show significant changes. In the region of low pressure, the passage of ions through the material increases slightly until it reaches a maximum and then it begins to decrease (Yunusov, 2011). The behavior of the rate of flow of the solution is observed in Figure 3.3 and that of the ion metal displacement in Figure 3.2. The quantity of transported ions, in function of the pressure, remains unchanged for each metal ion; the same response was observed in both, acidic and alkaline conditions.

In regard to the accumulation, maximum levels under basic conditions for M1 were observed at  $0.09 \text{ MPa}\cdot\text{m}^{-1}$ . In general, under alkaline conditions, values of accumulation in M2 were higher than those obtained for M1. However, significant differences were not observed in response to the change of pressure. Tables 3.4 and 3.5 present the accumulation percentages for M1 and M2 under alkaline conditions, respectively.

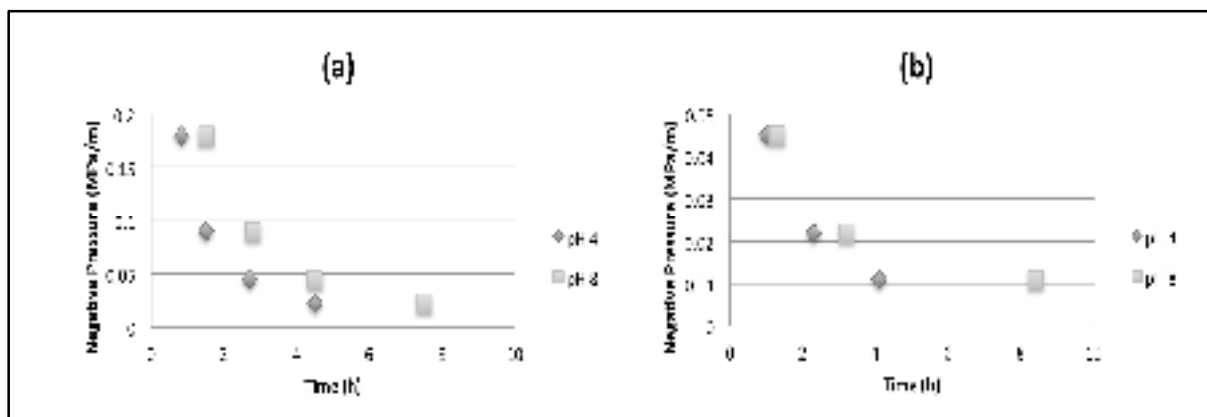

Figure 3.3 Time required to displace 250 mL of solution as a function of the vacuum pressure under acidic and basic conditions through (a) M1 and (b) M2

Table 3.4 Percentage of heavy metal accumulated in M1 under alkaline conditions at different pressures (P)  $\pm$  standard error (from three replicates)

Metal	Accumulated metal (%)			
	P = 0.022 MPa·m <sup>-1</sup>	P = 0.045 MPa·m <sup>-1</sup>	P = 0.090 MPa·m <sup>-1</sup>	P = 0.18 MPa·m <sup>-1</sup>
Pb	34.1 $\pm$ 5.6	34.8 $\pm$ 4.7	72.8 $\pm$ 9.4	57.8 $\pm$ 7.8
Ni	38.6 $\pm$ 0.8	36.9 $\pm$ 1.7	73.4 $\pm$ 1.7	59.5 $\pm$ 6.3
Zn	39.0 $\pm$ 0.7	36.5 $\pm$ 2.4	77.4 $\pm$ 0.5	61.8 $\pm$ 5.6
Al	34.5 $\pm$ 1.2	35.1 $\pm$ 0.6	76.9 $\pm$ 0.3	60.7 $\pm$ 7.6
Cr	35.4 $\pm$ 0.9	36.1 $\pm$ 1.5	77.9 $\pm$ 1.3	62.9 $\pm$ 6.6
As	45.4 $\pm$ 2.5	31.1 $\pm$ 5.5	51.7 $\pm$ 6.2	39.5 $\pm$ 1.1
Cd	68.1 $\pm$ 0.6	66.0 $\pm$ 2.1	83.8 $\pm$ 0.4	71.7 $\pm$ 1.3

Table 3.5 Percentage of heavy metal accumulated in M2 under alkaline conditions at different pressures (P)  $\pm$  standard error (from three replicates)

Metal	Accumulated metal (%)		
	P = 0.011 MPa·m <sup>-1</sup>	P = 0.022 MPa·m <sup>-1</sup>	P = 0.045 MPa·m <sup>-1</sup>
Pb	82.8 $\pm$ 1.1	65.8 $\pm$ 5.8	70.9 $\pm$ 7.0
Ni	71.3 $\pm$ 0.6	61.6 $\pm$ 10.3	61.9 $\pm$ 4.3
Zn	77.5 $\pm$ 0.3	70.6 $\pm$ 12.2	72.2 $\pm$ 5.8
Al	70.9 $\pm$ 12.6	70.6 $\pm$ 11.3	72.2 $\pm$ 8.6
Cr	80.2 $\pm$ 0.3	72.6 $\pm$ 12.3	74.9 $\pm$ 9.2
As	41.2 $\pm$ 2.8	22.1 $\pm$ 1.3	25.8 $\pm$ 2.9
Cd	58.2 $\pm$ 1.8	42.4 $\pm$ 3.7	49.7 $\pm$ 3.0

The high accumulation of heavy metals in the materials can be explained by the formation of insoluble compounds (Feng *et al.*, 2000), which have molecules of such volume that can be retained by the material (Gérente *et al.*, 2000). Furthermore, the reduction of pore space as a result of increased pressure must be taken into account; this behavior has been described as a thickening for the case of membranes (Yunusov, 2011).

### 3.3.3 Metals in the soil-plant system

Accumulator and hyperaccumulator plants work as a means of transport of specific heavy metals by taking up the metal in the soil solution and depositing it in their aerial parts. The ability of the plant to transport the metal is a key factor in the process of phytoextraction because it allows the removal of the contaminant when the aerial parts are harvested. On the contrary, a low transport to the aerial parts and a high accumulation of metals on the roots make the plant an important candidate for its application in phytostabilization processes that reduce the mobility of metals in soils (Kim *et al.*, 2003). In this respect, the tested materials showed an important capacity for transporting metals in the operating conditions used, particularly under acidic conditions.

#### 3.3.3.1 Hyperaccumulation criteria

Some authors take as a criterion for defining hyperaccumulator species those that expose a metal to soil ratio [ $\text{mg Metal}\cdot\text{kg}^{-1}$  dry matter] greater than  $100 \text{ mg}\cdot\text{kg}^{-1}$  for Cd;  $1000 \text{ mg}\cdot\text{kg}^{-1}$  for Cr, Pb, Ni, As and Al and  $10000 \text{ mg}\cdot\text{kg}^{-1}$  for Zn (Environment Canada, 2003; Shah, 2010). Taking into consideration these criteria, the tested materials can be assessed in terms of total transported metal  $[[\text{Pb}] + [\text{Ni}] + [\text{Zn}] + [\text{As}] + [\text{Al}] + [\text{Cr}] + [\text{Cd}]]$  in relation to the dry weight of the used material (presented in Table 3.2). Results showed an average ratio of  $788 \text{ mg}\cdot\text{kg}^{-1}$  for M1, and  $1104 \text{ mg}\cdot\text{kg}^{-1}$  for M2 in acidic conditions, whereas this ratio presented a considerably low value,  $90 \text{ mg}\cdot\text{kg}^{-1}$  for M1 and  $234 \text{ mg}\cdot\text{kg}^{-1}$  for M2, under basic conditions.

On this latter subject, some authors have underlined the importance of seeking hyperaccumulator species that allow the transport of several metals at the same time because the soil contaminated with heavy metals usually contains a variety of these (Cui, *et al.*, 2007; Riffat *et al.*, 2010). In this respect, the tested materials clearly exhibited the capacity to transport several metals altogether, but further studies may be focused on the evaluation of

the transport of a single ion until reaching conditions of saturation, in order to know the particular transport capacity and to compare the hyperaccumulation ratio.

### 3.3.3.2 Mobility of heavy metals in the soil-plant system

In acidic conditions, the mobility of the studied metals in the tested materials was, in increasing order: Al=Pb<Cr<Ni=Cd<Zn=As for M1, and Al<Pb=Cr=Ni<Cd=Zn=As for M2. Similar trends have been found for the mobility of metals in soil under acidic conditions and in the soil-plant system. In soils, reported mobility was Pb<Cr=Al<Ni<Zn<Cd (Kabata-Pendias and Pendias, 2001), whereas in the soil-plant system Pb=Cr=As<Ni<Zn=Cd, when expressed as a soil-plant transfer coefficient (Alloway and Jackson, 1991), both in increasing order. Unlike the soil-plant system, As was an easily transported metal in the tested materials, this element showed a high mobility in both acidic and basic conditions.

According to the literature, in the soil-plant system, metals such as Pb, Cr and Al show more difficulty to be mobilized, while Ni, Zn and Cd can be transported more easily; that is why metals like Pb and Cr, with a low mobility, are generally referred to as to be retained in the roots and used in phytostabilization methods (Kammev and Van der Lelie, 2000; Pulford and Watson, 2003;), while metals such as Cd, Zn and Ni, which have high solubility and are readily bioavailable for plants, are referred to as to be easily transported to the shoots and used in phytoextraction methods (Lassat, 2002; Pulford and Watson, 2003; Yoon *et al.*, 2006).

One last important point to note is that, although results were superior for M2 because it presented lesser interactions with most of the metals, the lightness of this material caused dragging and compacting problems in the outlet section during the course of the experiments. Thus, despite the fact that M1 presented a lower transport, this material was found more suitable when subjected to vacuum pressure.

### 3.4 Conclusions

The transport of metal ions in materials with a pore diameter similar to that in the xylem of vascular plants under similar pressure conditions to those found in the transpiration phenomenon of this kind vegetables was effective for Ni, Cd, Zn and As under acidic conditions in both materials (M1 and M2). The rise of the vacuum pressure did not result in an augmentation of the content of metal ions in the outlet solution. M1 was the material that exhibited more similarities with the transport of metal ions in the soil-plant system. In ascending order, transported ions in the solution at pH=4 for M1 were  $Al=Pb < Cr < Ni = Cd < Zn = As$  and for M2  $Al < Cr = Pb = Ni < Cd = Zn = As$ . Under alkaline conditions, M1 transported As while M2 presented important results for the transport of As and Cd.

Currently, the behaviour of heavy metals in soils is not well known. Some authors have argued that there is a remarkable similarity between the xylem and soil, from which the xylem may be considered an extension of the soil that allows similar flow characteristics (Sperry, *et al.*, 2003). The methodology developed in the present work made noticeable some similarities between the tested materials and vascular plants in relation to the transport of ions, which may be applied in the determination of the potential mobility of heavy metals and in the prediction of the feasibility of application of phytoremediation technologies in contaminated sites, even though the performance of the tested materials should be investigated when exposed directly to contaminated soils. So far, in the literature no similar studies have been found that evaluate the issue from this point of view.

The reproduction of the phenomenon that enables plants to carry out the phytoextraction and phytostabilization processes could lead to the development of less aggressive techniques, such as excavation-disposal and solidification of contaminated soils, making the operation easier and reducing discrepancies that arise when it comes to compare different species exposed to changing environmental conditions, as reported for several case studies with very particular conditions.



## Acknowledgments

The authors wish to thank Mrs. Mirela Sona for technical assistance in the ICP-OES analysis.

## 3.5 References

- Alloway, B. J., Jackson, A. P. (1991). *The Behaviour of Heavy metals in Sewage Sludge-Amended Soils*. Science of the Total Environment 100, 151-176.
- Anawar, H. M., Alam, M. T., Majibur, M. (2008). *Phytofiltration of Water Polluted with Arsenic and Heavy Metals*. International Journal of Environment and Pollution 33(2-3), 292-312.
- Blais, J. F., Meunier, N., Mercier, G. (2010). *New Technologies for Toxic Metals Removal from Contaminated Sites*. Recent Patents on Engineering 4(1), 1-6.
- Campbell, N. A., Reece, J. B. (2004). *Biology*. Seventh ed., Benjamin Cummings, Brussels, p. 1482.
- Cui, S., Zhou, Q., Chao, L. (2007). *Potential Hyperaccumulation of Pb, Zn, Cu and Cd in Endurant Plants Distributed in an Old Smeltery, Northeast China*. Engineering Geology 51(1), 1043-1048.
- Cunningham, S. D., Berti, W. R., Huang, J. W. W. (1995). *Phytoremediation of Contaminated Soils*. Trends in Biotechnology 13(9), 393-397.
- Environment Canada (2003). *Phytorem - Potential Green Solutions for Metal Contaminated Sites*. <http://www.ec.gc.ca/Publications/default.asp?lang=En&xml=B8A7B13F-FF7B-4375-BBAF-2DE33346C127>. Accessed June 11, 2011.
- Feng, D., Aldrich, C., Tan, H. (2000). *Treatment of Acid Mine Water by Use of Heavy Metal Precipitation and Ion Exchange*. Minerals Engineering 13(6), 623-642.
- Fritioff, A., Greger, M. (2003). *Aquatic and Terrestrial Plant Species with Potential to Remove Heavy Metals from Stormwater*. International Journal of Phytoremediation 5(3), 211-224.
- Gérente, C., Couespel du Mesnil, P., Andrès, Y., Thibault, J.-F., Le Cloirec, P. (2000). *Removal of Metal Ions from Aqueous Solution on Low Cost Natural Polysaccharides. Sorption Mechanisms Approach*. Reactive and Functional Polymers 46(2), 135-144.

- Ghorbani, H. (2008). *Factors Controlling the Bioavailability of Potentially Harmful Metals in Wastewater Treated Soils*. Proceedings of the International Meeting on Soil Fertility Land Management and Agroclimatology, Kusadasi, Turkey, October 29-31, 2008, p. 987-996.
- Glick, B. R. (2003). *Phytoremediation: Synergistic Use of Plants and Bacteria to Clean Up the Environment*. *Biotechnology Advances* 21(5), 383-393.
- Jarup, L. (2003). *Hazards of Heavy Metal Contamination*. *British Medical Bulletin* 68(1), 167-182.
- Kabata-Pendias, A., Pendias, H. (2001). *Trace Elements in Soils and Plants*. Third ed., CRC Press, Boca Raton, London, New York, Washington DC, p. 403.
- Kabata-Pendias, A. (2004). *Soil-Plant Transfer of Trace Elements: An Environmental Issue*. *Geoderma* 122(1), 143-149.
- Kamnev, A. A., Van der Lelie, D. (2000). *Chemical and Biological Parameters as Tools to Evaluate and Improve Heavy Metal Phytoremediation*. *Bioscience Reports* 20(4), 239-258.
- Kim, I. S., Kang, H. K., Johnson-Green, P., Lee, E. J. (2003). *Investigation of Heavy Metal Accumulation in Polygonum Thunbergii for Phytoextraction*. *Environmental Pollution* 126(1), 235-243.
- Kirkham, M. B. (2006). *Cadmium in Plants on Polluted Soils: Effects of Soil Factors, Hyperaccumulation and Amendments*. *Geoderma* 137(1), 19-32.
- Krämer, U. (2003). *Phytoremediation to Phytochelatin-Plant Trace Metal Homeostasis*. *New Phytologist* 158(1-9), 4-6.
- Krishnamurti, G. S. R., Naidu, R. (2008). *Chemical Speciation and Bioavailability of Trace Metals*. In: A. Violante, P. M. Haug, G. M. Gadd (Eds.), *Biophysico-Chemical Processes of Heavy Metals and Metalloids in Soil Environments*. First ed., Wiley Interscience, New Jersey, p. 419-466.
- Kukier, U., Peters, C., Chaney, R. A., Roseberg, J. (2004). *The Effect of pH on Metal Accumulation in Two Alyssum Species*. *Journal of Environmental Quality* 33(1), 2090-2102.
- Lassat, M. M. (2002). *Phytoextraction of Toxic Metals: A Review of Biological Mechanisms*. *Journal of Environmental Quality* 31(1), 109-120.
- Nijsee, J. (2004). *On the Mechanism of Xylem Vessel Length Regulation*. *Plant Physiology* 134(1), 32-34.

- Peijnenbur, W. (2004). *Fate of Contaminants in Soil*. In: P. Doelman, H. J. P. Eijsackers (Eds.), *Vital Soil Function, Value and Properties*. Elsevier, p. 245-280.
- Pulford, I. D., Watson, C. (2003). *Phytoremediation of Heavy Metal-contaminated Land by Trees - A Review*. *Environment International* 29(1), 529-540.
- Reddad, Z., Gérente, C., Andres, Y., Le Cloirec, P. (2002). *Adsorption of Several Metal Ions onto a Low-Cost Biosorbent Kinetic and Equilibrium Studies*. *Environmental Science & Technology* 36(9), 2067-2073.
- Riffat, N. M., Syed, Z. H., Ishfaq, N. (2010). *Heavy Metal Contamination and Accumulation in Soil and Wild Plant Species from Industrial Area of Islamabad, Pakistan*. *Pakistan Journal of Botany* 42(1), 291-301.
- Robinson, B., Grenn, S., Mills, T., Clothier, B., van der Velde, M., Laplane, R., Fung, L., Deurer, M., Husrst, S., Thayalakumaran, T., van den Dijssel, C. (2003). *Phytoremediation: Using Plants as Biopumps to Improve Degraded Environments*. *Australian Journal of Soil Research* 41(3), 599-611.
- Saeed, A., Akhter, W., Iqbal, M. (2005). *Removal and Recovery of Heavy Metals from Aqueous Solution Using Papaya Wood as a New Biosorbent*. *Separation and Purification Technology* 45(1), 25-31.
- Shah, F., Ahmad, N., Masood, K., Peralta-Video, J., Ahmad, F. (2010). *Heavy Metal Toxicity in Plants*. In: M. Ashraf, M. Ozturk, M. S. A. Ahmad (Eds.), *Plant Adaptation and Phytoremediation*. Springer-Verlag, New York, p. 71-97.
- Singh, R., Dhanial, G., Sharma, A., Jaiwal, P. (2007). *Biotechnological Approaches to Improve Phytoremediation Efficiency for Environment Contaminants*. In: S. N. Singh, R. D. Tripathi (Eds.), *Environmental Bioremediation Technologies*. Springer-Verlag, Berlin, p. 223-258.
- Sperry, J., Volker, S., Uwe, G. H. (2003). *Xylem Hydraulics and the Soil-Plant-Atmosphere Continuum: Opportunities and Unresolved Issues*. *Agronomy Journal* 95(1), 1362-1370.
- Taiz, L., Zeiger, E. (2010). *Calculating Velocities of Water Movement in the Xylem and in Living Cells*. *Plant Physiology*, Fifth Online ed. <http://www.plantphys.net>. Accessed October 10, 2011.
- Tremel-Schaub, A., Feix, I. (2005). *Soil Contamination. Transfert from Soils to Plants (Contamination des Sols. Transferts des Sols vers les Plantes)*. First ed., EDP Sciences-ADEME Editions, Les Ulis-Angers, p. 413.

- United States Department of Agriculture (USDA). (1998). *Soil Quality Indicators: pH*. Soil Quality Information Sheet of the Natural Resources Conservation Service. <http://soils.usda.gov/sqi/publications/files/indicate.pdf>. Accessed January 25, 2011.
- Vargas-Nieto, C., Carrizao, J. G., Castillo, E. (2011). *A Study of Low-cost Adsorbent Materials for Removing Cr(VI) from Aqueous Waste Effluent*. Ingeniería e Investigación 31(1), 154-162.
- Ying, G., Murray, P., Sauvé, S., Hendershot, W. (2002). *Low Metal Bioavailability in Contaminated Urban Site*. Environmental Toxicology and Chemistry 21(5), 954-961.
- Yoon, J., Cao, X., Zhou, Q., Ma, L. Q. (2006). *Accumulation of Pb, Cu, and Zn in native plants growing on a contaminated Florida site*. Science of the Total Environment 368(1), 456-464.
- Yu, L. J., Shukla, S. S., Dorris, K. L., Shulka, A., Margrave, L. S. (2003). *Adsorption of Chromium from Aqueous Solutions by Maple Sawdust*. Journal of Hazardous Materials B 100(1-3), 53-63.
- Yunusov, B. (2011). *Improving Ecological Parameters of Wastewater by Integrating Various Cleaning Methods*. Chemical and Petroleum Engineering 47(1-2), 133-139.

## CHAPTER 4

### TRANSPORT COEFFICIENT FOR HEAVY METALS IN POROUS MATERIALS

<sup>a</sup>Norma Oropeza, <sup>b</sup>Robert Hausler, <sup>c</sup>Mathias Glaus, <sup>d</sup>Ricardo Vega, <sup>e</sup>Rabindranarth Romero

<sup>a, b, c, d</sup> Station expérimentale des procédés pilotes en environnement, École de technologie supérieure, Université du Québec, Canada, 1100, rue Notre-Dame Ouest, H3C 1K3, Montréal, Québec, Canada.

<sup>e</sup>Universidad Veracruzana, Facultad de Ingeniería Civil, Lomas del Estadio s/n 91000, Zona Universitaria, Xalapa, Veracruz, México.

This article was submitted for publication in the Journal of Environmental Chemical Engineering; On date: 2013-02-20; Manuscript confirmation: JECE-D-13-00176

#### Abstract

One key characteristic to identify species with potential for phytoremediation is the enrichment coefficient which reflects the effectiveness of a plant for transporting metals from the contaminated medium, soil or water, to its aerial parts. The transport of soil solution from the root to the higher parts takes place in the xylem vessels through capillarity and transpiration phenomena. Based on the aforementioned, the objective of the present study was to propose and estimate a transport coefficient for heavy metals ( $TC_{HM}$ ) in porous materials, analogously to the enrichment coefficient in plants, by passing heavy metal solutions through two materials (M1 and M2) with similar pore diameter to that found in the xylem and by applying a negative pressure to emulate the transpiration conditions. Determination of the concentration of metals in the inlet and outlet solutions was made through Inductively Coupled Plasma. The tested materials showed effectiveness to transport heavy metals under acidic conditions, where most of the ions are available in solution.  $TC_{HM}$  of the tested materials ranged from 0.08 to 1.02, being  $TC_{HM} = 1$  the theoretical value of the

best transport performance expected, which indicates that there are not interactions between metal and the material.

**Keywords:** transport coefficient, heavy metals, porous materials, capillary action, transpiration, soil solution, hyperaccumulator plants

#### 4.1 Introduction

Heavy metals are released into the environment by human activities causing severe damage to ecosystems where they are also introduced into the food chain (Belluck *et al.*, 2006; Blais *et al.*, 2010; Dermont *et al.*, 2008; Sun *et al.*, 2007). Plants take up contaminants in the transpiration steam (Robinson *et al.*, 2003) and some species transport heavy metals from the roots to their aerial parts (leaves, stems, fruits, seeds) allowing the mobility and accumulation of these toxic elements (Kim, *et al.*, 2003).

In recent years, research on translocation and hyperaccumulation of heavy metals in plants has been greatly developed because of the usefulness of many species for their application in different phytotechnologies such as: phytoextraction (Cunningham *et al.*, 1995; Yang, 2008), phytostabilization (Kvesitadze *et al.*, 2006; Vidali, 2001), rhizofiltration (Anawar *et al.*, 2008; Kavesitadze *et al.*, 2006), etc. to remediate soil or water contaminated with this kind of pollutants (Gosh and Singh, 2005a; McGrath and Zhao, 2002).

A key feature to identify species with potential for phytoremediation is the enrichment coefficient (EC), also called bioconcentration factor (Malik *et al.*, 2010; Yoon *et al.*, 2006), defined as the ratio of the concentration of metal in the aerial parts of the plant to the concentration of metal in the soil. EC reflects the effectiveness of a plant to transport metals from the contaminated medium (soil or water) to the top of the plant (Abhilash *et al.*, 2009; Branquinho *et al.*, 2007; Haque *et al.*, 2008). Through the EC, plants can be classified as accumulators ( $EC > 1$ ), indicators ( $EC = 1$ ) or excluders ( $EC < 1$ ) (Baker, 1981; Branquinho *et al.*, 2007).

The transport of soil solution from the root to the aerial parts of plants takes place in the xylem, consisting of capillary vessels composed mainly of cellulose with diameter ranging from 10 to 200  $\mu\text{m}$  (Hacke, 2006). This transport is the result of both capillary action and transpiration, which can generate suction pressures of around  $0.02 \text{ MPa}\cdot\text{m}^{-1}$  (Taiz and Zeiger, 2010), among other phenomena (Figure 4.1a). Some authors have described this mechanism as a wick, with the terrestrial plants connecting the soil to the atmosphere (Harper, 1977) and other authors as a biopump capable of extracting not only water but also the pollutants contained in soils (Robinson *et al.*, 2003).

In this sense, the xylem of vascular plants represents an interesting part of the mechanism, because the increase in transport would make the process of phytoextraction more efficient (McGrath and Zhao, 2003; Zhao *et al.*, 2002). Furthermore, similarities between the hydraulic behaviour of xylem and soil have been exposed as an area of opportunity in the soil-plant-atmosphere system (Sperry *et al.*, 2003).

In this context, the present study aimed at proposing and estimating a transport coefficient of heavy metals ( $\text{TC}_{\text{HM}}$ ), by analogy to the EC, for two materials with pore diameter similar to that of the xylem of plants, using solutions in acidic and alkaline conditions and applying suction pressures proportional to those found in vascular plants.

## **4.2 Materials and methods**

### **4.2.1 Capillary means of transport**

A capillary wick (Figure 4.1b) was made in plastic pipes (0.8 cm diameter and 30 cm long) packed with two different materials (M1 and M2) as a capillary means of transport. Table 4.1 show the characteristics of the tested materials. Before being packed, the pipes were washed with a nitric acid solution (10%  $\text{HNO}_3$ ) for 3 hours and rinsed with distilled water. The tested materials were washed using distilled water for 3 hours and set to constant weight.

Table 4.1 Characteristics of the materials tested for the transport of heavy metals in solution

Material	Weight (g)	Material pore diameter	Material Composition
M1	2.4	20-25 $\mu\text{m}$	Cellulose 99%
M2	1.2	20-30 $\mu\text{m}$	Polyester 80%-polyamide 20%

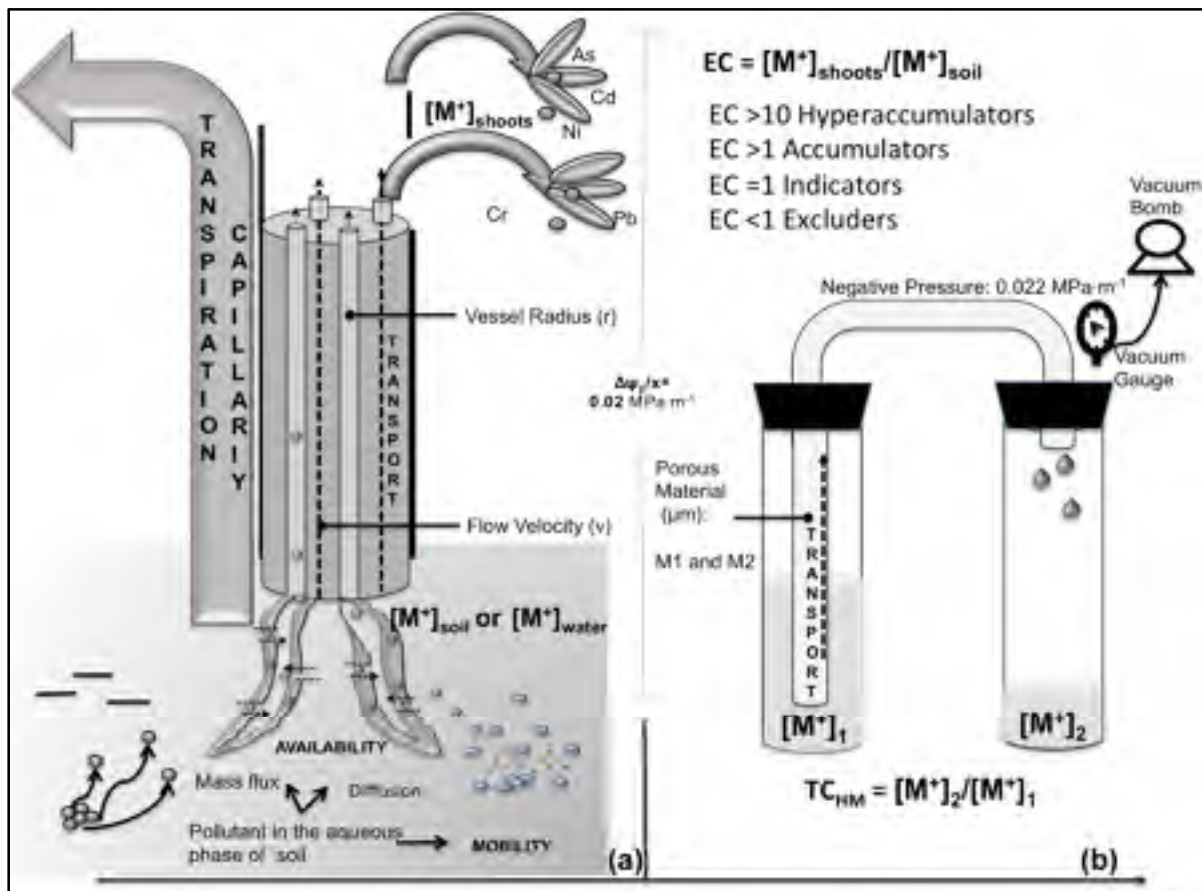

Figure 4.1 (a) Soil solution transport in vascular systems and (b) experimental arrangement



#### **4.2.2 Heavy metal solutions**

In order to evaluate the transport of heavy metals through the wick, two solutions were prepared, at pH 4 and pH 8, by adding 1.5 mL of a multielement standard solution (1000  $\mu\text{g}\cdot\text{L}^{-1}$ , 5%  $\text{HNO}_3$  and 10%  $\text{HCl}$ , SCP SCIENCE brand) containing As, Al, Cd, Cr, Ni, Pb and Zn in 1 L of distilled water. The soluble fraction of heavy metals in the inlet solution at pH 4 and 8 was tested using filters of 0.45  $\mu\text{m}$  (Whatman).

The solution at pH 4 was adjusted by adding Fisher environmental grade water. The solution at pH 8 was adjusted with water and by adding 1M NaOH solution (97% NaOH, Anachemia brand).

#### **4.2.3 Pressure assumption**

Considering that the suction pressure estimated for trees to rise the soil solution 1 m is about 0.02  $\text{MPa}\cdot\text{m}^{-1}$  (Taiz and Zeiger, 2010), a proportional pressure was taken in the experiments to create a similar effect to the transpiration phenomenon in the xylem of vascular plants, that is 0.0067 MPa for a 30 cm displacement of the solutions containing the metal ions (Figure 4.1b). To evaluate the transport of metal ions in M1 and M2, 250 mL of solutions at pH 4 and pH 8 were suctioned at the above-mentioned pressure.

#### **4.2.4 Heavy metal determination**

Heavy metal concentration in the inlet and outlet solutions was measured by ICP OES Varian Vista MPX model. The calibration curve fit was obtained with a 0.99 correlation coefficient. The wavelengths ( $\lambda$ ) used for the metals were: lead,  $\lambda = 220.353$  nm; nickel,  $\lambda = 231.604$  nm; zinc,  $\lambda = 213.857$  nm; arsenic,  $\lambda = 228.812$  nm aluminum,  $\lambda = 396.152$  nm; chrome,  $\lambda = 267.716$  nm and cadmium,  $\lambda = 226.502$  nm. The calculation of the quantity of metals transported and accumulated in the tested materials (M1 and M2) was made by material balance.

#### 4.2.5 Calculation of transport coefficient of heavy metals (TC<sub>HM</sub>)

In plants, the enrichment coefficient is defined as the ratio of heavy metal concentration in the aerial parts to the metal concentration in the soil (Eq. 4.1); this relationship can be used to evaluate the heavy metal accumulation capacity of a plant (Brankovic *et al.*, 2001; Ghosh and Singh, 2005; Liao *et al.*, 2004; Sasmaz and Sasmaz, 2009).

$$EC = \frac{[\text{Metal}]_{\text{shoot}}}{[\text{Metal}]_{\text{soil}}} \quad (4.1)$$

By analogy, the transport coefficient of heavy metals for the tested materials was obtained (Eq. 4.2); this coefficient allows an estimation of the capacity for transporting the heavy metal solution.

$$TC_{\text{HM}} = \frac{[\text{Metal}]_{\text{outlet}}}{[\text{Metal}]_{\text{inlet}}} \quad (4.2)$$

Annex II shows 106 EC values reported for plant species in different parts of the world, of which less than 1% exhibit an  $EC \geq 1$ .

#### 4.2.6 Statistical analysis

Data, obtained in triplicate ( $n=3$ ) were subjected to ANOVA analysis. Differences between treatments were tested by comparison of means (LSD-test). Measures were considered significantly different if  $P < 0.05$ . Statistical analysis was performed using the statistical software JMP8 (SAS Institute Inc.).

### 4.3 Results and discussion

#### 4.3.1 Transport, accumulation and $TC_{HM}$ in acidic conditions

The transport coefficients calculated for each metal are presented in Table 4.2. In acidic conditions, the concentration of the solution transported through M1 shows little variation for Ni, Zn, As and Cd; as a consequence, a  $TC_{HM} \approx 1$  was estimated for these metals, while a  $TC_{HM} < 1$  was calculated for Cr, Pb and Al, due to the accumulation of metal ions in the material (Figure 4.2).

Table 4.2 Transport coefficient ( $TC_{HM}$ ) obtained for the tested materials (means  $\pm$  standard error from three replicates)

Metal	pH conditions			
	pH = 4		pH = 8	
	M1	M2	M1	M2
Pb	$0.10 \pm 0.011$	$0.87 \pm 0.112$	$0.00 \pm 0.009$	$0.05 \pm 0.038$
Ni	$1.02 \pm 0.010$	$1.02 \pm 0.014$	$0.02 \pm 0.003$	$0.12 \pm 0.046$
Zn	$0.99 \pm 0.007$	$1.01 \pm 0.004$	$0.00 \pm 0.00$	$0.03 \pm 0.010$
Al	$0.08 \pm 0.055$	$0.87 \pm 0.015$	$0.00 \pm 0.00$	$0.02 \pm 0.009$
Cr	$0.55 \pm 0.064$	$0.93 \pm 0.018$	$0.00 \pm 0.000$	$0.00 \pm 0.000$
As	$0.96 \pm 0.110$	$0.97 \pm 0.03$	$0.19 \pm 0.019$	$0.57 \pm 0.121$
Cd	$0.99 \pm 0.094$	$0.99 \pm 0.019$	$0.01 \pm 0.001$	$0.43 \pm 0.091$

In the case of M2, all the metal ions exhibit a  $TC_{HM} \approx 1$ , reflecting that the concentration of the input solution is kept while passing through the material, because of the little interaction metal-material, which reduces their accumulation in it. Figure 4.2 shows the percentages of total metal ions accumulated and transported by the tested materials.

For M1, in acidic conditions, the transport was around 60% of ions with an accumulation of 29%, being retained in the material mainly Pb, Al and Cr. For M2, the transport was close to 78% of the total metal ions with an accumulation of less than 10%. Thus, significant differences were observed with regard to total metal transport and accumulation.

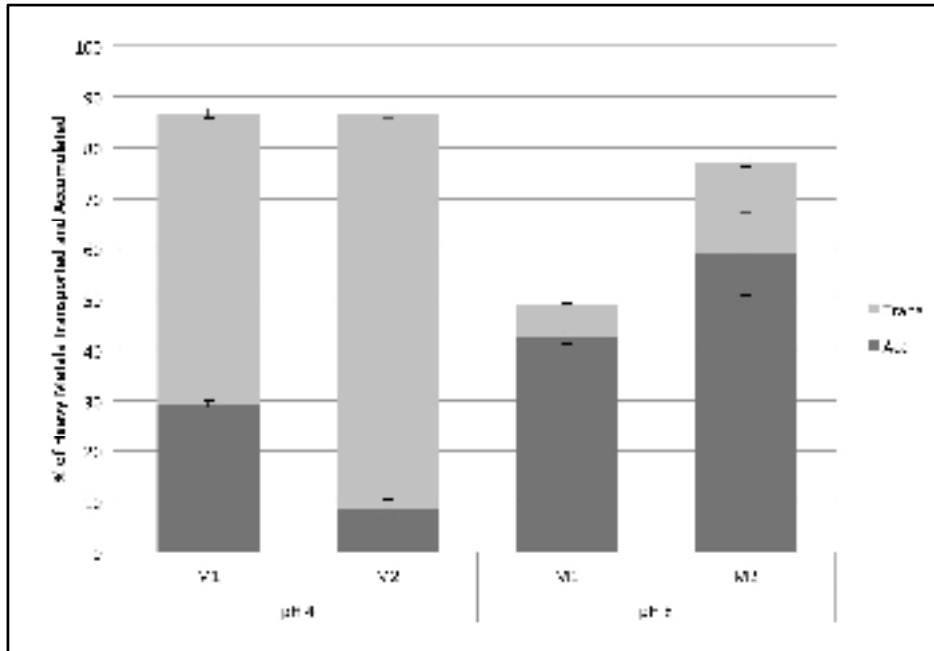

Figure 4.2 Total percentages of heavy metals transported and accumulated in acidic and basic conditions for M1 and M2

The ratio  $[\text{Metal}]_{\text{outlet}}/[\text{Metal}]_{\text{soluble in the inlet solution}}$  can be seen in the table 4.3 in order to compare with the  $\text{TC}_{\text{HM}}$ . These results suggest that non-dissolved molecules are transported through the wicks.

Table 4.3 Ratio  $[\text{Metal}]_{\text{outlet}}/[\text{Metal}]_{\text{soluble in the inlet solution}}$   
(means  $\pm$  standard error from three replicates)

Metal	pH conditions			
	$[\text{Metal}]_{\text{outlet}}/[\text{Metal}]_{\text{soluble in the inlet solution}}$			
	pH = 4		pH = 8	
	M1	M2	M1	M2
Pb	$0.15 \pm 0.015$	$1.16 \pm 0.112$	$2.28 \pm 3.952$	$7.57 \pm 3.753$
Ni	$1.41 \pm 0.033$	$1.42 \pm 0.014$	$2.97 \pm 0.473$	$5.19 \pm 0.218$
Zn	$1.47 \pm 0.079$	$1.53 \pm 0.004$	$11.10 \pm 0.398$	$42.97 \pm 4.961$
Al	$0.10 \pm 0.076$	$1.05 \pm 0.015$	$1.02 \pm 0.031$	$1.39 \pm 0.114$
Cr	$0.70 \pm 0.065$	$1.18 \pm 0.018$	$0.00 \pm 0.000$	$0.00 \pm 0.000$
As	$1.46 \pm 0.017$	$1.43 \pm 0.103$	$0.47 \pm 0.043$	$1.64 \pm 0.016$
Cd	$1.29 \pm 0.096$	$1.36 \pm 0.023$	$0.13 \pm 0.011$	$0.94 \pm 0.063$

#### 4.3.2 Transport, accumulation and $\text{TC}_{\text{HM}}$ in basic conditions

The mobility of the metal ions under alkaline conditions is greatly reduced due to the formation of hydroxides and their accumulation in the materials. For M1, transport of metal ions was minimum (only 6%) and the accumulation rate was 42%, whereas for M2, the observed values of transport and accumulation were 17% and 59%, respectively (Figure 4.2).

In these conditions, M1 showed a  $\text{TC}_{\text{HM}} = 0$  for Pb, Ni, Zn, Al, Cr and Cd, and a  $\text{TC}_{\text{HM}} \approx 0.2$  for As (Table 4.2). For M2, the transport of metal ions is also reduced considerably; however, this material presented a  $\text{TC}_{\text{HM}} \approx 0.5$  for As and Cd as shown in Table 4.2. Similarly to the acidic conditions, significant differences were observed between M1 and M2 regarding the total transported and accumulated metals.

### 4.3.3 Transport coefficient of heavy metals ( $TC_{HM}$ ) and enrichment coefficient (EC)

Most plants present an  $EC < 1$  and plants growing in contaminated soils show an  $EC < 0.2$  (McGrath and Zhao, 2003), as a consequence, the vast majority of plants behave as metal excluders. Currently, accumulator and hyperaccumulator species are screened using EC. Species with  $EC > 1$  are considered prospects in phytoextraction processes because these species allow the active transport of metals to their aerial parts. Most of the time, these species are selective (in terms of the metals that can be removed), have low biomass and grow on contaminated sites (Clemens *et al.*, 2002; Krämer, 2003). Numerous case studies have been reported in the literature; as mentioned above, Annex II shows that very few species present an  $EC > 1$ .

From the viewpoint of transport, the ability of hyperaccumulator plants for transferring the contaminant from the soil to the shoot of the plant allows the elimination of the contaminant by harvesting, while for the case of the phytostabilization, the plant roots act as a heavy metal sequestrator membrane that prevents the movement of the heavy metals from the ground to other horizons and towards the surface (Kvesitadze *et al.*, 2006).

In this regard, the tested materials proved that, under certain conditions, the transport of heavy metals by capillary means is possible, reaching  $TC_{HM} = 1$ , which shows that the concentration of several metals remains unchanged when the solution is transported through the material. This feature can be very useful when applied in the transport of the soil solution to remove contaminants.

Unlike plant cells, bounded by a surface barrier, the tested materials do not act as selective membrane controlling actively the type of substance and the amount that passes through. In this case, materials acting as a means of transport, the best performances showed  $TC_{HM} = 1$ , meaning there is no interaction between heavy metal and material, which puts them in a similar level of that of indicator species. Results of the present work demonstrate that transport of heavy metal solutions through porous materials is possible. However, this

transport must be tested directly in samples of polluted soil, to attempt to create an extension of the porous matrix of soil focusing in the transport of matter.

#### **4.4 Conclusions**

The transport coefficient of heavy metals ( $TC_{HM}$ ) defined as the ratio of the initial concentration, before passing through the material, to the concentration at the outlet, after passing through the material, shows that, under certain conditions, some metals are transported out in the aqueous phase. The tested materials exhibited effectiveness for transporting heavy metals under acidic conditions, where most of the ions are available in solution. However in the case of arsenic, this metal also showed a significant mobility under basic conditions.

Furthermore, the composition of the materials is also an important point at issue because of the interactions that may arise with the metals in solution. In terms of transporting, for the tested materials,  $TC_{HM}=1$  is the best level of performance expected theoretically, meaning that there are not interactions between metal and material, and as a consequence, its concentration in the solution remains unchanged. In contrast to the estimated coefficients for the tested materials, only six of those reported for plants showed an  $EC > 1$  for one specific metal (Annex II), while the materials tested in the present work did carry various metals at the same time.

Nowadays, most of the processes to remediate soils are aimed at the isolation of them (excavation, vitrification, solidification, etc.), nevertheless, continuous systems of treatment must be explored in order to develop less drastic solutions. In this sense, phytoremediation and its associated processes offer a range of solutions that are feasible to be replicated by engineering techniques and tested.

From the standpoint of soil as a porous medium, taking into account that its aqueous phase is the component allowing the mobility of the soluble contaminants contained in it, the possibility of setting up a continuum between both porous mediums (soil and tested material) to recover pollutants, and in this way to prevent their spread to other parts of ecosystems, should be investigated more thoroughly. In this sense, the creation of an artificial continuity by using porous materials can be the key in the development of soil remediation processes based on phytoremediation techniques.

#### 4.5 References

- Abhilash, P. C., Pandey, V. C., Srivastava, P., Rakesh, P. S., Chandran, S., Singh, N., Thomas, A.P. (2009). *Phytofiltration of Cadmium from Water by Limnocharis flava (L.) Buchenau Grown in Free-floating Culture System*. Journal of Hazardous Materials 170(2-3), 791-797.
- Anawar, H. M., Alam, M. T., Maijibur, M. (2008). *Phytofiltration of Water Polluted with Arsenic and Heavy Metals*. International Journal of Environment and Pollution 33(2-3), 292-312.
- Baker, A. J. M. (1981). *Accumulators and Excluders: Strategies in the Response of Plants to Trace Metals*. Journal of Plant Nutrition 3, 643-654.
- Bech, J., Duran, P., Roca, N., Poma, W., Sánchez, I., Barceló, J., Boluda, R., Roca-Pérez, L., Poschenrieder, C. (2012). *Shoot Accumulation of Several Trace Elements in Native Plant Species from Contaminated Soils in the Peruvian Andes*. Journal of Geochemical Exploration 113, 106-111.
- Belluck, D. A., Benjamin, S. L., David S. (2006). *Why Remediate?* In: G. Echevarria, N. Goncharova, J. L. Morel (Eds.), *Phytoremediation of Metal-contaminated Soils*. Springer-Verlag, Dordrecht, p. 1-23.
- Blais, J. F., Meunier, N., Mercier, G. (2010). *New Technologies for Toxic Metals Removal from Contaminated Sites*. Recent Patents on Engineering 4(1), 1-6.
- Boer, H. A., Volkov, V. (2003). *Logistics of Water and Salt Transport Through the Plant: Structure and Functioning of the Xylem*. Plant, Cell & Environment 26(1), 87-101.
- Brankovic, S., Pavlovic-Muratspahic, D., Topuzovic, M., Glisic, R., Bankovic, D., Stankovic, M. (2011). *Environmental Study of Some Metals on Several Aquatic Macrophytes*. African Journal of Biotechnology 19(56), 11956-11965.



- Branquinho, C., Serrano, H., Pinto, M. J., Martins-Loucao, M. A. (2007). *Revisiting the Plant Hyperaccumulation Criteria to Rare Plants and Earth Abundant Elements*. Environmental Pollution 146(1), 437-433.
- Chao, W., Xiao- Chen, L., Li-Min, Z., Pei-Fang, W., Zhi-Yong, G. (2007). *Pb, Cu, Zn and Ni Concentrations in Vegetables in Relation to Their Extractable Fractions in Soils in Suburban Areas of Nanjing, China*. Polish Journal of Environmental Studies 16(2), 199-207.
- Clemens, S., Palmgren, M., Krämer, U. (2002). *A Long Way Ahead: Understanding and Engineering Plant Metal Accumulation*. Trends in Plant Science 7(1), 309-315.
- Cunningham, S. D., Berti, W. R., Huang, J. W. W. (1995). *Phytoremediation of Contaminated Soils*. Trends in Biotechnology 13(9), 393-397.
- Dermont, G., Bergeron, M., Mercier, G., Laflèche-Richer, M. (2008). *Metal-Contaminated Soils: Remediation Practices and Treatment Technologies*. Practice Periodical of Hazardous, Toxic and Radioactive Waste Management 12(3), 188-209.
- Gérente, C., Couespel du Mesnil, P., Andrès, Y., Thibault, J.-F., Le Cloirec, P. (2000). *Removal of Metal Ions from Aqueous Solution on Low Cost Natural Polysaccharides. Sorption Mechanisms Approach*. Reactive and Functional Polymers 46(2), 135-144.
- Ghosh, M., Singh, S. P. (2005). *A Review on Phytoremediation of Heavy Metals and Utilization of It's by Products*. Asian Journal on Energy and Environment 6(4), 214-231.
- Hacke, U. G., Sperry, J. S., Wheeler, J. K., Castro, L. (2006). *Scaling of Angiosperm Xylem Structure with Safety and Efficiency*. Tree Physiology 26(6), 689-701.
- Haque, N., Peralta-Videa, J. R., Jones, G. L., Gill, T. E., Gardea-Torresdey, J. L. (2008). *Screening the Phytoremediation Potential of Desert Broom (Baccharis sarothroides Gray) Growing on Mine Tailings in Arizona, USA*. Environmental Pollution 153(2), 362-368.
- Harper, J. L. (1977). Population Biology of Plants. First ed., Academic Press, New York, p. 900.
- Hegazy, A. K., Abdel-Ghani, N. T., El-Chaghaby, G. A. (2011). *Phytoremediation of Industrial Wastewater Potentiality by Typha domingensis*. International Journal of Environment Science and Technology 8(3), 639-648.
- Kim, I. S., Kang, H. K., Johnson-Green, P., Lee, E. J. (2003). *Investigation of Heavy Metal Accumulation in Polygonum Thunbergii for Phytoextraction*. Environmental Pollution 126(1), 235-243.

- Krämer, U. (2003). *Phytoremediation to Phytochelatin-Plant Trace Metal Homeostasis*. New Phytologist 158(1-9), 4-6.
- Kvesitadze, G., Khatishashvili, G., Sadunishvili, T., Ramsden, J. (2006). *Biochemical Mechanisms of Detoxification in Higher Plants: Basis of Phytoremediation*. First ed., Springer-Verlag, Berlin Heidelberg, p. 262.
- Li, Y., Zu, Y., Fang, Q., Gao, Z., Schwartz, C. (2009). *Relationship Between Heavy Metal Concentrations of Herbaceous Plants and Soils at four Pb-Zn Mining Sites in Yunnan, China*. Frontiers of Environmental Science and Engineering in China 3(3), 325-333.
- Liao, X. Y., Chen, T. B., Lei, M., Huang, Z. C., Xiao, X. Y., An, Z. Z. (2004). *Root Distributions and Elemental Accumulations of Chinese Brake (Pteris vittata L.) from As-contaminated Soils*. Plant and Soil 261(1-2), 109-116.
- Lorestani, B., Cheraghi, M., Yousefi, N. (2011). *Phytoremediation Potential of Native Plants Growing on a Heavy Metals Contaminated Soil of Copper mine in Iran*. World Academy of Science, Engineering and Technology 77(1), 377-382.
- Malik, R. N., Husain, S. Z., Nazir, I. (2010). *Heavy Metal Contamination and Accumulation in Soil and Wild Plant Species from Industrial Area of Islamabad, Pakistan*. Pakistan Journal of Botany 42(1), 291-301.
- McGrath, S. P., Zhao, F. J., Lombi, E. (2002). *Phytoremediation of Heavy Metals, Metalloids and Radionuclides*. Advanced in Agronomy 75, 1-56.
- McGrath, S. P., Zhao, F. J. (2003). *Phytoextraction of Metals and Metalloids from Contaminated Soils*. Current Opinion in Biotechnology 14(3), 277-282.
- Robinson, B., Grenn, S., Mills, T., Clothier, B., van der Velde, M., Laplane, R., Fung, L., Deurer, M., Husrst, S., Thayalakumaran, T., van den Dijssel, C. (2003). *Phytoremediation: Using Plants as Biopumps to Improve Degraded Environments*. Australian Journal of Soil Research 41(3), 599-611.
- Sasmaz, A., Sasmaz, M. (2009). *The Phytoremediation Potential for Strontium of Indigenous Plants Growing in a Mining Area*. Environmental and Experimental Botany 67(1), 139-144.
- Sperry, J., Volker, S., Uwe, G. H. (2003). *Xylem Hydraulics and the Soil-Plant-Atmosphere Continuum: Opportunities and Unresolved Issues*. Agronomy Journal 95(1), 1362-1370.

- Sun, L., Niu, Z., Sun, T. (2007). *Effects of Amendments of N, P, Fe on Phytoextraction of Cd, Pb, Cu, and Zn in Soil of Zhangshi by Mustard, Cabbage, and Sugar Beet*. *Environmental Toxicology* 22(6), 565-571.
- Taiz, L., Zeiger, E. (2010). *Calculating Velocities of Water Movement in the Xylem and in Living Cells*. *Plant Physiology*, Fifth Online ed. <http://www.plantphys.net>. Accessed October 10, 2011.
- Usman, R. A., Lee, S. S., Award, Y. M., Lim, K. J., Yang, J. E., Ok, Y. S. (2012). *Soil Pollution Assessment and Identification of Hyperaccumulating Plants in Chromated Copper Arsenate (CCA) Contaminated Sites, Korea*. *Chemosphere* 87(8), 872-878.
- Vidali, M. (2001). *Bioremediation. An Overview*. *Pure and Applied Chemistry* 73(7), 1163-1172.
- Xiaohai, L., Yuntao, G., Khan, S., Gang, D., Aikui, C., Li, L. Y., Lei, Z., Zhonghan, L., Xuecan, W. (2008). *Accumulation of Pb, Cu, and Zn in Native Plants Growing on Contaminated Sites and Their Potential Accumulation Capacity in Heqing, Yunnan*. *Journal of Environmental Science* 20(12), 1469-1474.
- Yang, L. (2008). *Phytoremediation: An Ecotechnology for Treating Contaminated Sites*. *Practice Periodical of Hazardous, Toxic, and Radiative Waste Management* 21(4), 290-298.
- Yanqun, Z., Yuan, L., Schwartz, C., Langlade, L., Fan, L. (2004). *Accumulation of Pb, Cd, Cu and Zn in Plants and Hyperaccumulator Choice in Lanping Lead-Zinc Mine Area, China*. *Environment International* 30(1), 567-576.
- Yoon, J., Cao, X., Zhou, Q., Ma, L. Q. (2006). *Accumulation of Pb, Cu, and Zn in native plants growing on a contaminated Florida site*. *Science of the Total Environment* 368(1), 456-464.
- Zhao, F. J., Dunham, S. J., McGrath, S. P. (2002). *Arsenic Hyperaccumulation by Different Fern Species*. *New Phytologist* 156(1), 27-31.



## CHAPTER 5

### DISCUSSION

This section of the thesis presents the theoretical and practical considerations that led to the development of a model, which puts forward the possibility of displacing the aqueous phase of the soil through a continuous system formed by soil and material; both porous media allow the movement of the soil solution from a contaminated soil. A similar transport occur in vascular plants when these carry the heavy metals in solution to their aerial parts or accumulate them in their roots.

#### 5.1 A conceptual model of heavy metal transport in the soil-material continuum

By analogy to some features observed in the xylem of vascular plants, the model was developed considering *i*) the transport of solutions in a porous material M1 (biomaterial composed by cellulose) featuring capillary transport of heavy metals; *ii*) the simulation of a negative pressure effect of the same magnitude of that reported for the xylem of plants ( $-0.02 \text{ MPa}\cdot\text{m}^{-1}$ ); and *iii*) a coefficient of transport ( $\text{TC}_{\text{HM}}$ ) depending on the type of material, pH and transported metal ion, which was estimated based on similar criteria to that used to identify phytoaccumulator species of heavy metals.

##### 5.1.1 Model approach

The following paragraphs summarize the concepts tested in the experimental work that were applied in the model development.

In the first article, using materials with capillary properties similar to those found in the xylem of vascular plants, the transport of heavy metal ions was tested. For the same concentration of solution in acidic and basic conditions, the experiments demonstrated that the capillary transport of metal ions is effective for various heavy metal ions at the same

time, particularly under acidic conditions; this is also linked to the characteristics of the material used for the transport. Thus, although the tested materials have similar pore diameter, the number of active sites present on the surface of them modifies the amounts and types of heavy metal transported or accumulated in each material. The best performance for the transport of ions under acidic conditions was observed for M2, while M1 exhibited important similarities to that reported for the system soil-plant.

In the second article, the effect of the negative pressure on the transport and accumulation of metal ions on the materials was tested; the results showed that the rise of the vacuum pressure did not result in a significant augmentation of the content of metal ions in the outlet solution. Moreover, under suction pressure, the tested materials exhibited similar behaviour to that described for membranes.

In the third article, the  $TC_{HM}$  for each material was estimated depending on the metal ions found in the solution at different pH. The tested materials exhibited low levels of transport and accumulation for single metals when compared to hyperaccumulator plants (see Table 2.2). Nevertheless, transport coefficient values close to one were obtained for several metals, the same value used to classify plant species as indicators.

The results of the experimental work were the basis for the proposition of a system dynamics model that structures the different analogies studied.

### **5.1.2 Concepts integrated in the model**

The main structures that comprise the system can be described in terms of the following sub-systems: 1) pH and heavy metal mobility in soils, 2) pH and heavy metal in the soil solution, 3) capillary flow, 4) heavy metal transport by the tested materials, 5) capillary flow in the soil-material continuum (M1 or M2) and 6) heavy metal transport by the soil-material continuum (M1 or M2) from laboratory work. These sub-systems are displayed in Figure 5.1.

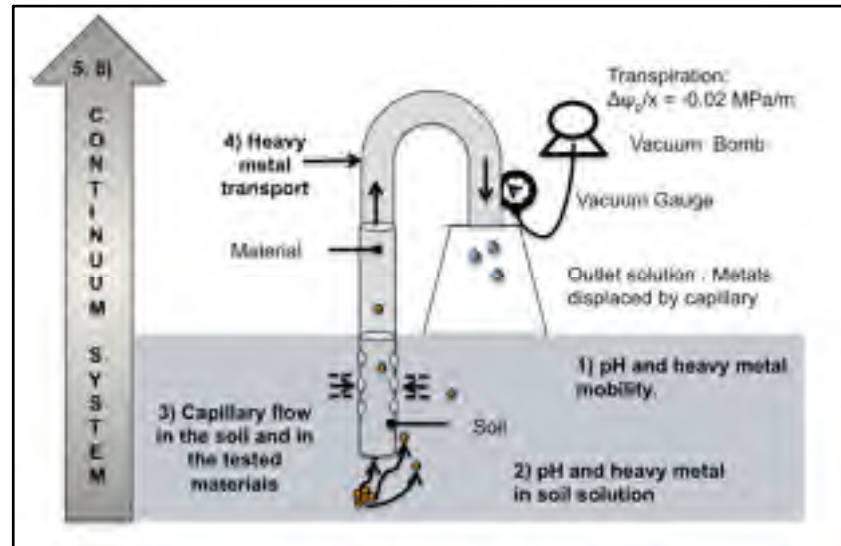

Figure 5.1 Diagram of the soil-material continuum

### 5.1.3 Modeling conditions

The results of laboratory work and key factors reported in the literature were considered in the interrelationship among the different variables included in the modelled system, which are listed below:

(a) soil pH and heavy metals mobility. pH of soils is a preponderant factor in the transfer of metal ions to the aqueous phase of the soil (Ghorbani, 2008; Ghosh and Singh 2005b; Kabata-Pendias and Pendias, 2001). Thus, heavy metal availability for plants is determined by their content in the aqueous phase (Bourrelier *et al.*, 1998; Fritioff and Greger, 2003; Girard *et al.*, 2005). In soils, the pH range is commonly found between 3.5 and 9 (USDA, 1998). The tendency of mobility of heavy metals in soils, with respect to pH, was considered as showed in Figure 1.5.

(b) transport under negative pressure. Transpiration effect in the xylem under negative pressure was taken into account by applying the Poiseuille equation (Eq. 1.1), the pressure gradient for the transport of water in the xylem vessels, calculated for trees, is about  $-0.02 \text{ MPa}\cdot\text{m}^{-1}$  (Taiz and Zeiger, 2010). Considering this value, a proportional negative pressure was taken in the experimental work to emulate a similar effect in the transport of heavy metal solutions through the tested materials. Also, the ratio of heavy metal concentration in the material (M1) to that in the solution was considered through the transport coefficient of heavy metals ( $\text{TC}_{\text{HM}}$ ), by analogy to the EC in plants.

(c) continuum porous media (soil-material). Xylem consists of sap-conducting vessels composed by cellulose (De Boer, 2003; Wu *et al.*, 1999). Pore diameter of the vessels is in a range going from 10 to 200  $\mu\text{m}$  (Hacke *et al.*, 2006). This capillary system allows the transport of the soil solution to the aerial parts of vascular plants (Campbell and Reece, 2004; Kvesitadze *et al.*, 2006; Nijsee, 2004). Similarities between the hydraulic behaviour of xylem and soil have been exposed as an area of opportunity in the soil-plant-atmosphere system (Sperry *et al.*, 2003). The permeability of the soil-material continuum was calculated by using equation 1.3.

(d) heavy metal transport or accumulation by the tested materials. According to the laboratory results, the materials exhibited capacity for transporting or accumulating heavy metals in solution; hence, their recovery in the outlet solution or the accumulation in the material reduces the concentration of heavy metals in the soil.



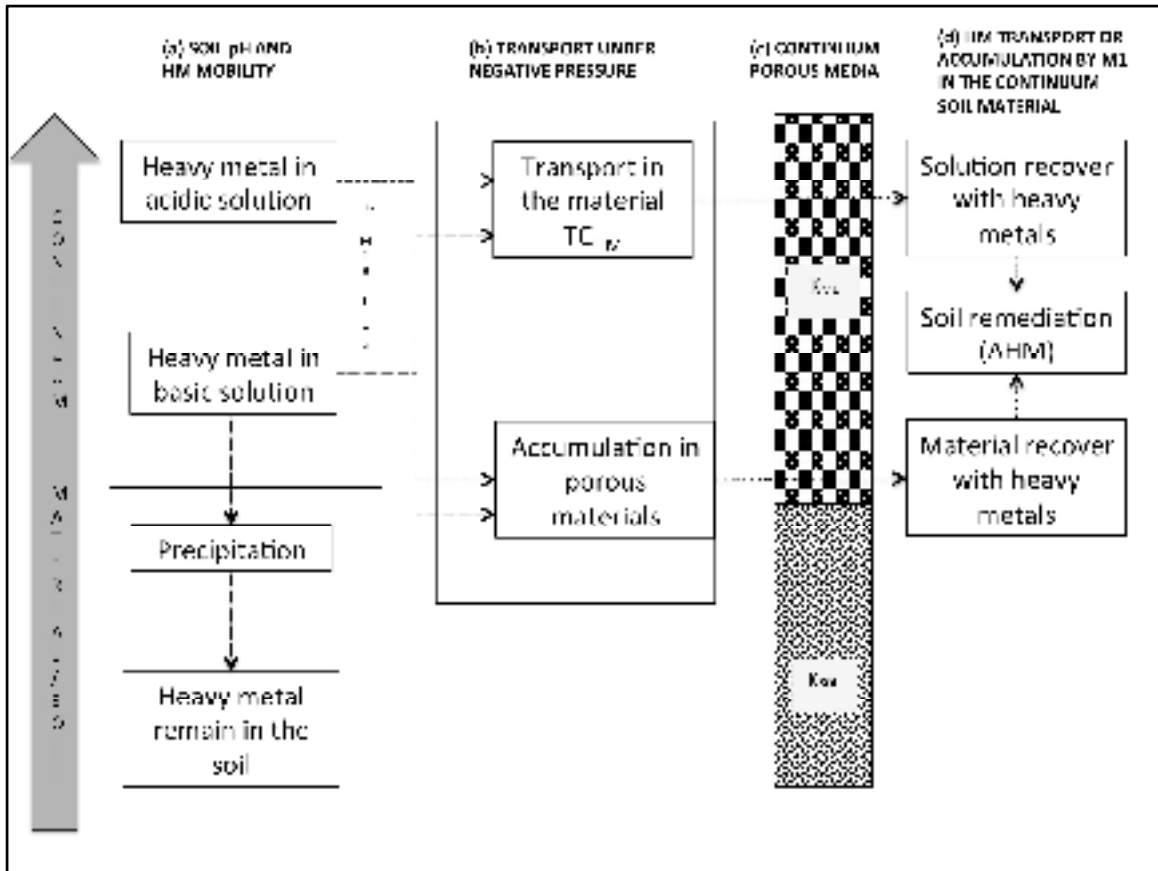

Figure 5.2 Schema of the soil-material continuum

The model depicts the relationship among the variables and reflects the subsystems connexions (Figure 5.2). System dynamics allows the study of the structure of a system and of the general patterns of behaviour within a range of practical values, which leads to the identification of the most important parameters and their global effect on the system (Brennan and Shelley, 1999). The system dynamics model, presented in Annex III, was developed using STELLA 9.1 (iseesystems, 2008). A schema of the model is illustrated in Figure 5.2; Table 5.1 summarizes the values considered for the variables previously described.

Most of the systems dynamics models are based on ordinary differential of difference equations (Voinov, 2008), in this case subject to the constraints of the law of conservation of mass and energy, which software such as Stella solves by numerical iteration methods.

Table 5.1 Values of the variables considered in the model

Variable	Assumptions
Variation of soil pH as a function of time (hours, pH)	(0, 8); (28, 7.5); (56, 6.94); (84, 6.42), (112, 5.78); (140, 4.66); (168, 4.52), (196, 4.52); (224, 5.0); (252, 6.5); (280, 7.0); (308, 7.0), (336, 7.0)
Pore radius of M1 (m)	0.00001
Negative pressure (MPa·m <sup>-1</sup> )	-0.02
TC <sub>HM</sub> for M1 (pH 4)	Pb: 0.10; Ni: 1.0; Zn: 0.99; Al: 0.08; Cr:0.55 ; Cd: 0.99
TC <sub>HM</sub> for M1 (pH 8)	Pb: 0.00; Ni: 0.02; Zn: 0.00; Al: 0.00; Cr:0.00 ; Cd: 0.01
Material permeability or K <sub>M1</sub> (m·h <sup>-1</sup> )	0.44
Soil permeability or K <sub>SOIL</sub> (m·h <sup>-1</sup> )	0.008
Thickness of material layer (m)	0.3
Thickness of soil layer (m)	0.3
Column diameter (m)	0.008
Permeability soil-material (m·h <sup>-1</sup> )	1.6
Heavy metal concentration in soil at t=0 (mg of HM·kg <sup>-1</sup> )	(Pb: 6900); (Ni: 4500); (Zn: 5000); (Al: 500); (Cr: 3950); (Cd: 345)
HM pH mobility	Considering the mobility trends in Figure 1.5

#### 5.1.4 Model results

Considering the transport coefficients obtained for M1, under laboratory conditions at pH= 4 and 8, and at negative pressure P=0.02 MPa·m<sup>-1</sup>, the proposed model was used to estimate the amounts of heavy metals transported and accumulated by M1. The amounts obtained in the laboratory were compared to the results produced by the model. Table 5.2 shows these results, no significant differences were observed.

Table 5.2 Laboratory results vs. model results

Heavy metal	Results			
	Laboratory		Model	
	Transported (mg)	Accumulated (mg)	Transported (mg)	Accumulated (mg)
Pb	0.044	0.35	0.042	0.32
Ni	0.041	0.038	0.042	0.031
Zn	0.57	0.021	0.56	0.016
Al	0.032	0.39	0.033	0.34
Cr	0.21	0.20	0.23	0.18
Cd	0.39	0.04	0.42	0.034

The soil-material continuum model was used to make a prospection of the extraction of heavy metals, considering the pH variations indicated in Table 5.1. Ranges of concentration in soils for each metal and permissible limit values in non-residential soils are displayed in Table 5.3; the last column shows the amount of heavy metals remaining in 1 kg of soil ( $\Delta$ HM, see Equation 5.1) after 336 hours, estimated by the model, in which, the data highlighted in bold in the column of the concentration ranges were used as initial values of the concentration.

Table 5.3 Heavy metals in soil: range and regulatory limits  
 From: <sup>a</sup>Riley *et al.* (1992, p. 28) and NJDEP (1999) <sup>b</sup>Non-residential direct contact soil clean up criteria

Heavy Metal	Soil concentration range <sup>a</sup> (mg·kg <sup>-1</sup> )	Regulatory limits <sup>b</sup> (mg·kg <sup>-1</sup> )	$\Delta$ HM (mg·kg <sup>-1</sup> ) according to the model
Pb	1.0- <b>6,900</b>	600	785
Ni	140- <b>5,000</b>	2,400	15
Zn	150.00- <b>5,000</b>	1,500	21
Al	1- <b>500</b>	-	13.4
Cr	0.05- <b>3,950</b>	100	81.7
Cd	0.1- <b>345</b>	100	0.01

According to the model, Figure 5.3 shows the amount of heavy metals in 1 kg of soil for a given time ( $\Delta HM$ , see Equation 5.1) for an interval of 14 days of continuous operation; in general, the total removal of metals reached values higher than 90% after that period.

$$\Delta HM = HM_{soil} - (HM_{Trans} + HM_{Acc}) \quad (5.1)$$

Where:  $\Delta HM$ = heavy metal variation in 1 kg of soil;  $HM_{soil}$ = heavy metal in soil (mg) at  $t=0$ ,  $HM_{Trans}$ = heavy metal transported by M1 (mg);  $HM_{Acc}$ = heavy metal accumulated by M1 (mg).

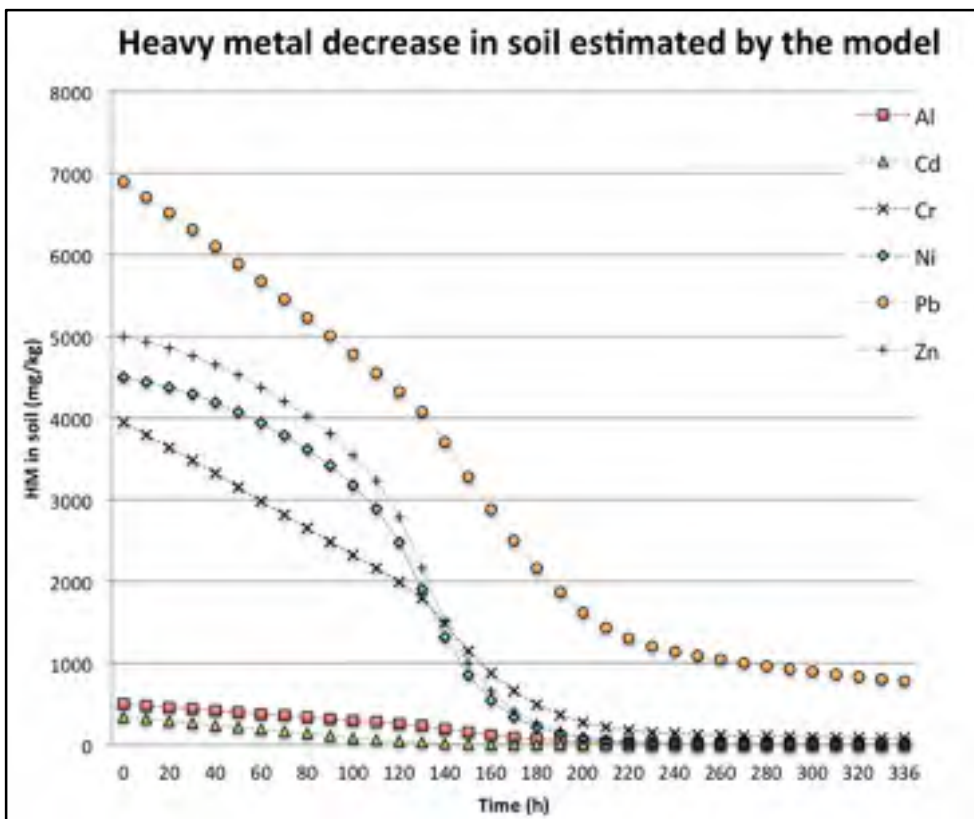

Figure 5.3 Behaviour of the heavy metal concentration estimated through the model

The initial values of concentration of the considered heavy metals in soils show important variations. Pb is the element with the highest concentration value and Cd is the one with the lowest. Due to the variation of pH, heavy metals tend to be removed from the soil, particularly in the interval ranging from 40 to 200 hours, moment in which pH reaches the lowest levels. After this point, the removal values become practically constant because there is a lower concentration of metals in the soil, which decreases the gradient between what remains and what will be removed and, also, owing to the increase in pH, which diminishes the mobility of metals.

#### **5.1.5 Limitations of the model**

The model was proposed based on the laboratory results, where accumulation and transport of heavy metals in the tested materials were observed making an analogy to the xylem of vascular plants; however, their behaviour should be studied when both porous media (soil-material) are coupled.

The model considered saturated conditions and large changes in pH levels. Although saturation conditions can be obtained in sites with high rainfall, changes in pH usually are not drastic in natural conditions; so, further work should focus on the study of the accumulation of metals in the materials when pH oscillates between 6.5 and 8.5, the most likely range of values present in soils in natural conditions.

Due to fact that oxidation states largely depend on the pH of the medium, different chemical species of the same element can be found at the same pH conditions. On the other hand, the mobility of metals in the environment does not have a constant value. Hence, other factors should be considered such as the presence of organic or inorganic ligands, biotic or abiotic conditions, redox reactions, and the fact that plants affect continuously the concentration and metal speciation in the soil solution and in water. In this regard, subsequent work may consider the speciation of elements to study the mobility of the species through the materials and testing the heavy metal transport in the soil-material continuum both in laboratory

conditions and directly in contaminated soils. Variables like change of temperature, heavy metals concentration and material composition should also be examined in future research.

## **5.2 Perspectives and recommendations**

The conceptual model proposed in this work reduces the number of variables involved in phytoremediation process. Metabolic aspects like the type of phytoextractor species, nutrient requirements for the growth of the plant and the environmental conditions modifying the plant development and the production of vegetable biomass are highly relevant in the selection of a phytoremediation technology; however, these kinds of features are not present in the transport or accumulation of heavy metals by the tested materials. From the proposed model, different arrangements can be considered for assessing the fixation of the metals contained in the soil solution passing through the material by testing with or without the application of the negative pressure. Finally, a very important point is that, when materials are removed, the metal recovery by desorption processes is guaranteed, while in phytoextraction processes it is not considered if the metal is adsorbed on the surface of the cell walls or if it is within the cells, which does not allow to know whether the metals can be recovered by desorption methods.

With respect to the materials, different aspects of them should be studied to determine their potential on new technologies based on the transport system of water in vascular plants, these include: type of material, modification of materials to promote the accumulation or transport of heavy metals, transport effects and accumulation in nanomaterials, particularly, in relation to the change of certain environmental variables (concentrations, temperature, pressure, type of contaminants, among others).

### 5.2.1 Artificial xylem technology by biomimicry to the soil-plant continuum

A process that promotes the formation of a continuous medium from soil through materials with similar characteristics to the xylem of vascular plants reduces the number of important factors maintaining a living species. Furthermore, the contaminant may be recovered in both the aqueous phase and in the material and, therefore, there is less risk of reintroducing the heavy metal in the food chain or into the soil. The model illustrated in Figure 5.4 raises a new option for soil decontamination rather than heavy metal isolation together with the soil, as most of the conventional methods currently used.

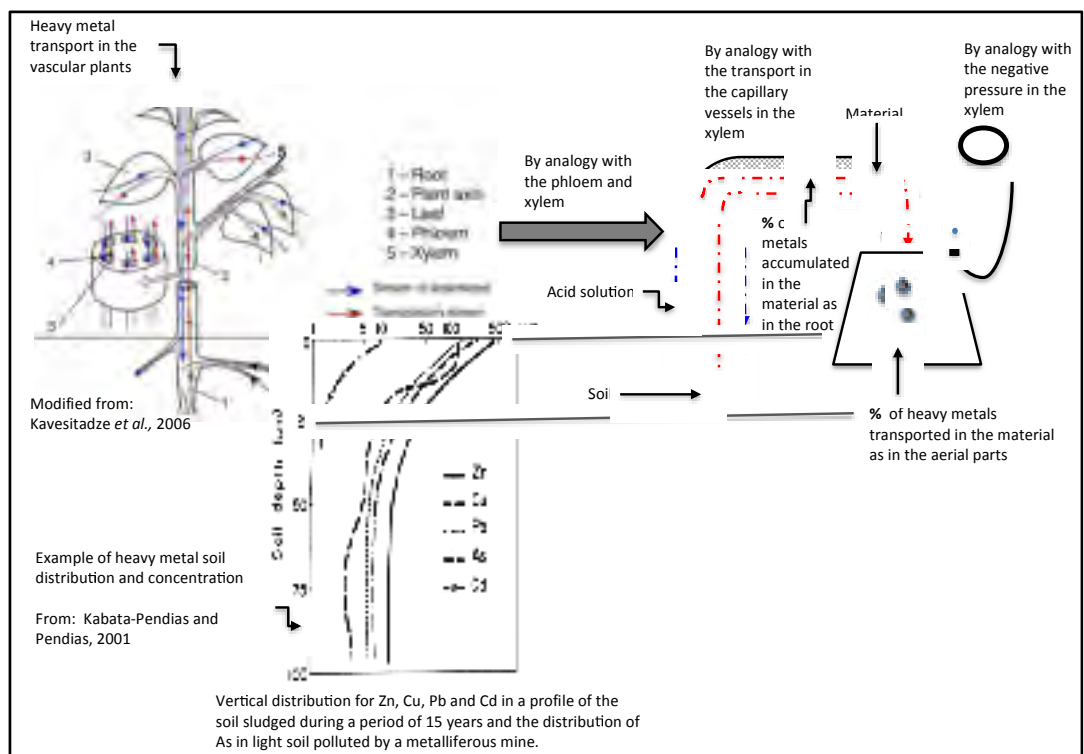

Figure 5.4 Technology based on the phytoextraction process

Until now, phytoextraction processes are being used in the rehabilitation of contaminated soils surface (depth: 0-60 cm). In this regard, the metal removal capacity of hyperaccumulator plants has an important role in the success of the process; nevertheless,

many variables are present when it comes to maintaining a living organism. Thus, temperature conditions, ground humidity, nutrients, site microbiota, soil pH, etc., determine, first, whether the species will be able to survive in the site to be rehabilitated and, subsequently, if such conditions will modify the extraction capacity of the plant. Added to this, it must be considered that these species allow the introduction of contaminants into the food chain and reintroduce the contaminant element to soils once the part of the contaminated plant perishes.

Due to the large number of variables that can modify the metabolism of a plant, many studies are performed at laboratory level trying to control most of them. As a result, significant variations in phytoextraction values are obtained when the species are evaluated directly in field.

### **5.2.2 Bioarrangements used to prevent soil pollution**

The use of biomaterials of low cost should be considered as an option since such materials are seen as wastes in various agricultural and food processes and are generated in large quantities.

In the developed model, pressure conditions similar to those reported for the xylem and a cylinder arrange for the material tested were used. However, in Article 1, the capillary properties of the materials showed that the movement through the pore spaces could result in transport or accumulation of heavy metals on the material surface depending on the conditions of pH, metal in solution and material. Given these characteristics, other arrangements, like those disclosed by the nature, should be tried, such as several forms of tubers and roots. These can be tested as preventive methods of soil contamination, by adding biomaterials on the surface, based on forms similar to those of carrots, beets, potatoes or a tangle of roots, which can be retrieved later and taken to disposal or undergo desorption processes for recovering the heavy metal, regenerating also the material for re-use.



In this way, the modification of biomaterials, or of the characterization of these, can result in the application of more suitable biomaterials for the type of metal present in the site of interest, the pH soil conditions and the type of active site in the material: carboxyl (R-COO-), hydroxyl (-OH), sulphate (R-OSO<sub>3</sub>-) and amino groups (R<sub>2</sub>-NH<sub>2</sub> and R-NH).

### 5.2.3 Heavy metal transport indicator: phytoextraction or phytostabilization

A qualitative indicator, which informs about the type of metal that can be transported by the plants to their aerial parts, or accumulated in their roots, is proposed. This, based on the similarities of the heavy metal transport obtained for M1 and on that reported in the literature for plants. Because this work was developed with solutions, the indicator proposed is obtained from soil solution, as shown in Figure 5.5.

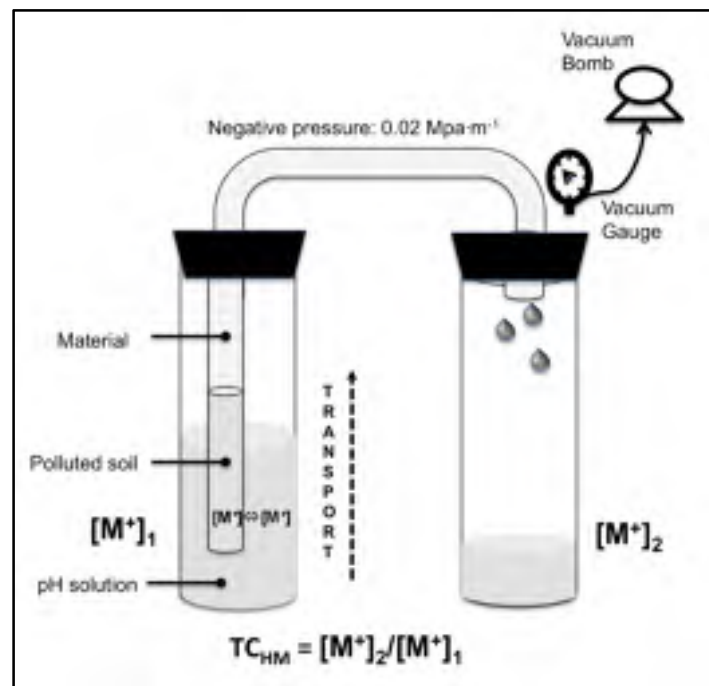

Figure 5.5 Qualitative indicator of heavy metal transport

Thus, in the soil-plant system, heavy metals like Pb, Cr and Al, with a low mobility, are

generally found in the roots, while metals such as Cd, Zn and Ni are easily transported to the shoots. Based on these similarities, heavy metals presenting  $TC_{HM} \approx 1$  when tested by using M1 (composed of 99% of cellulose) in acidic conditions, could be prospects for the application of phytoextraction methods and heavy metals presenting accumulation in M1 could be considered for phytostabilization processes.

## CONCLUSION

Nowadays, the ability of hyperaccumulator plants to extract and concentrate heavy metals in their aerial parts is a subject of great interest because its application in soil and water bioremediation puts forward alternatives to preserve these natural resource characteristics diminishing remediation costs in comparison to traditional methods. However, phytoremediation of heavy metals still has many challenges to overcome in order to be applied on-site with satisfactory results.

Several factors such as use of native plants, low biomass production, number of crops needed to reduce metal concentrations to acceptable standards, nutrient requirements in the soil for the plant growth which, coupled to environmental variables, can affect the growth of the plant, the chemical species of heavy metals and their availability in soil. All these aspects complicate the reproducibility of the phytoremediation processes on-site. Despite these limitations, plants exhibit capacities to accumulate heavy metals in their roots and, in other cases, to transport them to the leaves. Hence, the mechanisms used by plants to accumulate and transport heavy metals should be the basis for the development of new technologies.

Under this approach, this study was developed based on the water transport system of vascular plants. The work proposes a new technology based on the transport mechanisms described to translocate the soil solution from the soil to the aerial parts of plants. From the analogies reflected in the hypotheses of the work, the capillary transport of heavy metals (by emulsion to the capillary system in the xylem vessels), the effect of negative pressure (by resemblance to transpiration in plants) and a transport coefficient by analogy to the enrichment coefficient in plants (that allows the identification of hyperaccumulator species of heavy metals) were studied, in all cases, at acidic and basic conditions.

As in plants, similar patterns of accumulation and transport was observed in the tested materials; nevertheless, both the rate of accumulation and the rate of transport were affected by the pH conditions and by the functional group in the the materials surface, whereas the

pressure had a significant effect only on the rate of flow. Thus, the range of possibilities offered by the combination of these factors define research lines for future developments focused on the establishment of optimal combinations in function of the type of pollutant, the material properties and the environmental pH conditions.

A conceptual model inspired by the soil-plant system was developed to test a new technology based on the soil-material continuum. Removal rates for most of the heavy metals considered in the work, estimated through the proposed model, were around 90%.

Among the tested materials, biomaterials, composed mainly by cellulose, showed trends of heavy metal mobility similar to those reported by some authors in the soil-plant system. Due to the fact that cellulose is the primary component of plants and the biomolecule more abundant in Earth, this material may be the key for the implementation of various biosorbents for soils, which at present are tested for the elimination of heavy metals from water. Cellulose-based materials are commonly regarded as waste materials in food and agricultural processes, so that they are readily available.

A very important advantage in the use of materials instead of plants is that once the materials are recovered from the contaminated sites, the metal accumulated in them can be recovered by desorption techniques, whereas this is not always possible when working with plants because the metal may be trapped within the plant cells. Moreover, the regeneration of materials for re-use is another important point to consider when the application of materials is evaluated.

Future research should focus in the study of the practical implications of the conceptual model proposed here, which is based on the soil-plant continuum, taking into consideration different micro and nanomaterials with specific active groups according to the heavy metals and to the environmental conditions of the contaminated sites. Spherical, conical and spider-form arrangements, similar to those present in plants, should be essayed in order to determine better spatial arrangements that promote the accumulation and transport of heavy metals.

## ANNEX I

### Distribution of species present in the solution according to the pH

Chemical equilibrium diagrams and effect of pH to (a)  $\text{Pb}^{2+}$ , (b)  $\text{Ni}^{2+}$ , (c)  $\text{Zn}^{2+}$  and (d)  $\text{Cd}^{2+}$  by using Hydra and Medusa software.

(Puigdomenech, 2012) (<http://www.kth.se/che/medusa>).

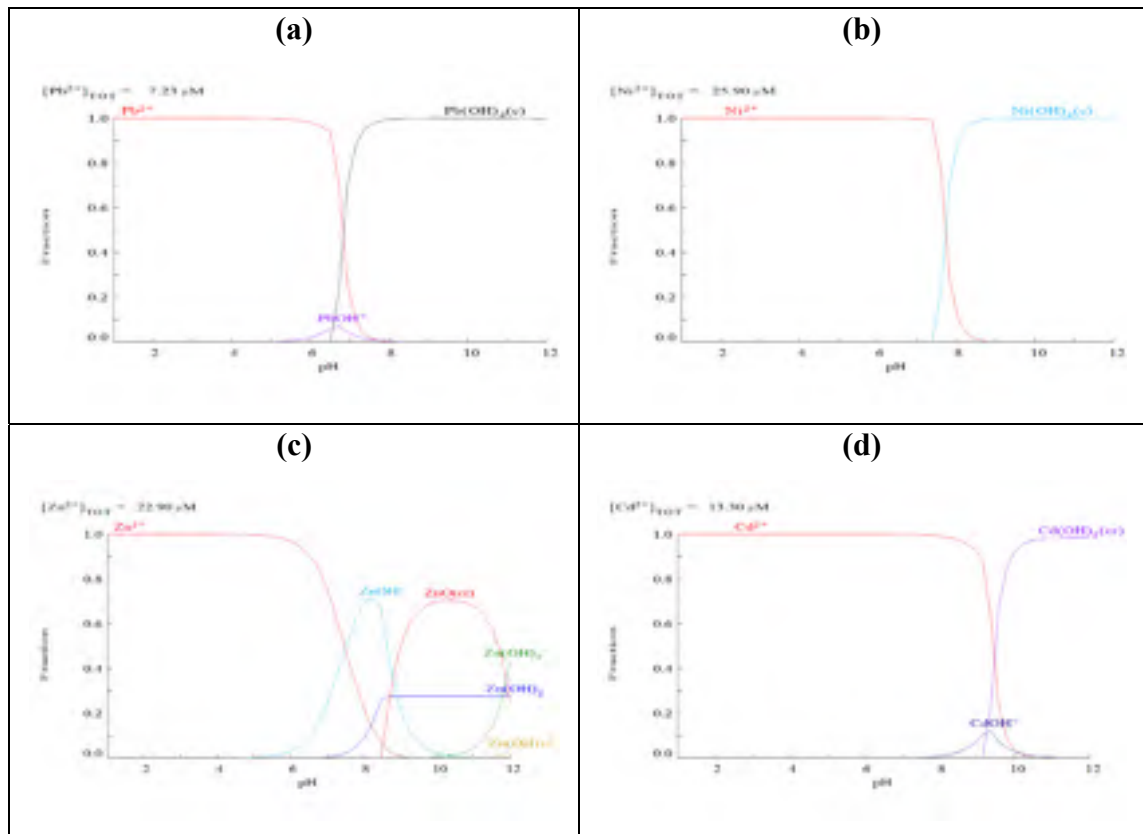

Chemical Equilibrium Diagrams and effect of pH to (a)  $\text{As}^{3+}$ , (b)  $\text{As}^{5+}$ , (c)  $\text{Cr}^{3+}$ , (d)  $\text{Cr}^{6+}$  and (e)  $\text{Al}^{3+}$  by using Hydra and Medusa software.

(Puigdomenech, 2012) (<http://www.kth.se/che/medusa>).

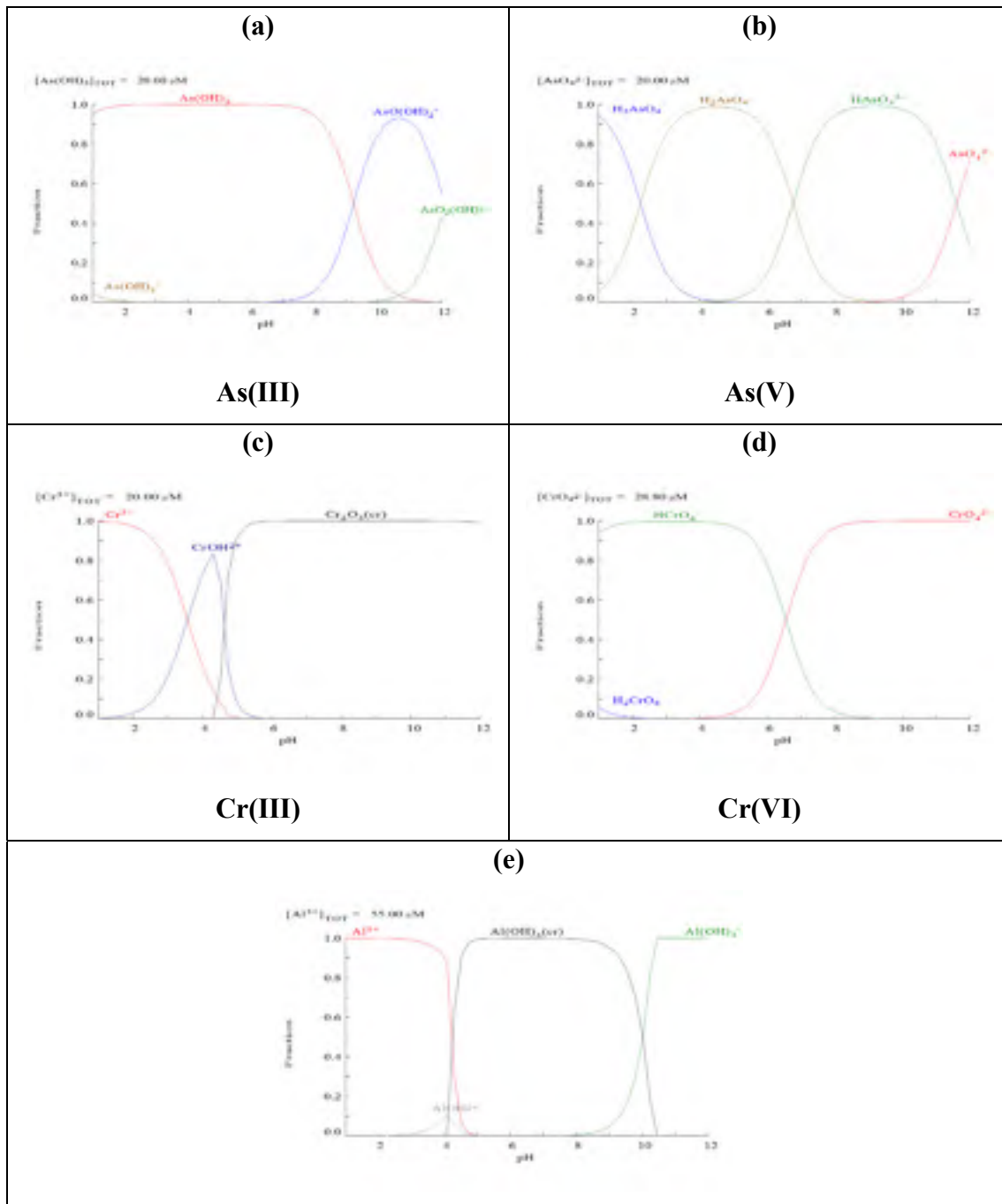

## ANNEX II

### Compilation of EC reported in the literature

Species	Enrichment Coefficient (EC)						
	Pb	Ni	Zn	Al	Cr	As	Cd
<b>Case Study: Yunnan, China</b>							
<b>Reference: Yanqun <i>et al.</i>, 2005</b>							
<i>Incarvillea sp.</i>			0.80				
<i>Corydalis pterygopetala Franch</i>			0.65				0.19
<i>Corydalis pterygopetala Hand-Mazz</i>							0.18
<i>Potentilla fulgens Wall.</i>							0.26
<i>Plantage erosa Wall. In Roxb</i>							0.38
<i>Picris hieracioides L. subsp. Japonica kryly</i>							0.16
<i>Arabis alpinal Var. parviflora Franch</i>	0.13		0.43				
<i>Arabis alpinal Var. parviflora Franch</i>	0.17		0.45				
<i>Sonchus asper (L.) Hill</i>	0.76		0.38				
<i>Stellaria vestita Kurz.</i>	0.48						
<i>Frescuta ovina L.</i>	0.61						
<i>Arenaria rotundifolia Bieberstein</i>	0.38						
<i>Oxalis corymbosa DC.</i>	0.65						
<i>Eupatorium adenophorum Spreng</i>	0.45						
<i>Crisium chlorolepis Petrak</i>	0.27						
<i>Taraxacum mongolicum Hand-Mazz</i>	0.17						
<i>Elsholtzia polisa</i>	0.18						

Species	Enrichment Coefficient (EC)						
	Pb	Ni	Zn	Al	Cr	As	Cd
<b>Case Study: El-Sadat City, Egypt</b>							
<b>Reference: Hegazy <i>et al.</i>, 2011</b>							
<i>Typha domingensis</i>				0.015			
<i>Typha domingensis</i>				6.78			

Species	Enrichment Coefficient (EC)						
	Pb	Ni	Zn	Al	Cr	As	Cd
<b>Case Study: Florida, USA</b>							
<b>Reference: Yoon <i>et al.</i>, 2006</b>							
<i>Gentiana pennelliana</i> Fern.	11		2.6				
<i>Gentiana pennelliana</i> Fern.	0.61		0.54				
<i>Cyperus esculentus</i> L.	0.11		0.83				
<i>Cyperus esculentus</i> L.	0.29		0.45				
<i>Phyla nodiflora</i> (L.)	0.05		0.03				
Greene	0.19		0.40				
<i>Rubus fruticosus</i>	0.2		0.15				
<i>L. agg.</i>	0.15		0.40				
<i>Sesbania herbacea</i>	1.1		1.5				
<i>Stenotaphrum secundatum</i>	1.0		0.82				
<i>Plantago major</i> L.	1.0		0.69				
<i>Bidens alba</i> var. <i>radiata</i>	2.0		0.13				

Species	Enrichment Coefficient (EC)						
	Pb	Ni	Zn	Al	Cr	As	Cd
<b>Case Study: Peruvian Andes</b>							
<b>Reference: Bech <i>et al.</i>, 2012</b>							
<i>S. oleraceus</i>	0.2		0.2				0.4
<i>S. oleraceus</i>	0		0.1				0.1
<i>B. latifolia</i>	6.5		5.7				0.1
<i>B. latifolia</i>	0.4		0.0				
<i>P. orbignyana</i>	3.6		4.0				
<i>P. orbignyana</i>	1.0		0.4				
<i>L. bipinnatifidum</i>	0.1		0.1				0.1



Species	Enrichment Coefficient (EC)						
	Pb	Ni	Zn	Al	Cr	As	Cd
<b>Case Study: Yunnan, China</b>							
<b>Reference: Xiaohai <i>et al.</i>, 2008</b>							
<i>Pteridium var</i>	0.003		0.40				
<i>Polygonum chinense</i>	0.01		0.20				
<i>Pteris ensiformis</i>	0.003		0.21				
<i>Polygonum rude</i>	0.002		0.46				
<i>Pteris fauriei Hieron</i>	0.005		0.29				
<i>Bauhinia variegata</i>	0.004		0.26				
<i>Artemisia lactiflora Wall</i>	0.37		0.22				
<i>Osyris wightiana</i>	0.004		0.40				
<i>Smilax China L.</i>	0.002		0.18				
<i>Aster subulatus Michx</i>	0.07		0.30				
<i>Conyza canadensis (L.) Cronq.</i>	0.07		0.13				
<i>Buddleia officinalis Maxim</i>	0.02		0.13				
<i>Colocasia esculenta</i>	0.30		0.12				
<i>Green vegetables</i>	0.10		0.15				
<i>Tender garlic shoot</i>	0.90		0.12				
<i>Ricinus communis L.</i>	0.40		0.16				
<i>Rumex hastatus</i>	0.80		0.16				
<i>Tephrosia candida</i>	0.80		0.14				
<i>Debregeasia orientalis</i>	0.02		0.15				

Species	Enrichment Coefficient (EC)						
	Pb	Ni	Zn	Al	Cr	As	Cd
<b>Case Study: Yunnan, China</b>							
<b>Reference: Li et al., 2009</b>							
<i>Stellariav vestita</i> Kurz.							0.57
<i>Stellariav vestita</i> Kurz.							0.84
<i>Stellariav vestita</i> Kurz.							0.18
<i>Taraxacum mongolicum</i> Hand-Mazz							0.32
<i>Taraxacum mongolicum</i> Hand-Mazz							0.39
<i>Picris hieracioides</i> L.							0.13
<i>Picris hieracioides</i> L.							0.63
<i>Cardamine flexuosa</i> With.							0.04
<i>Cardamine flexuosa</i> With.							0.73
<i>Lepidium apetalum</i> Wild.							0.52
<i>Rorippa palustris</i> (Leyss.) Bess							0.14
<i>Sinopteris grevilleoides</i>							0.2
<i>Sinopteris grevilleoides</i>							0.45
<i>Sinopteris grevilleoides</i>							0.17
<i>Pteris cretica</i> L.							0.21
<i>Pteris cretica</i> L.							0.03
<i>Pteris cretica</i> L.							0.16
<i>Pteris vittata</i>							0.45
<i>Pteris vittata</i>							0.11

Species	Enrichment Coefficient (EC)						
	Pb	Ni	Zn	Al	Cr	As	Cd
<b>Case Study: Nanjing, China</b>							
<b>Reference: Chao et al., 2007</b>							
<i>Apium graveolens</i>	0.10	1.01	0.47				
<i>Allium sativum</i> Linn	0.14	0.69	0.43				
<i>Brassica oleracea</i> var. <i>viridis</i>	0.13	1.11	0.46				
<i>Spinaca oleracea</i>	0.09	1.48	0.42				

Species	Enrichment Coefficient (EC)						
	Pb	Ni	Zn	Al	Cr	As	Cd
<b>Case Study: Hamadan, Iran</b>							
<b>Reference: Lorestani <i>et al.</i>, 2011</b>							
<i>E. Macroclada</i>			0.43				
<i>C. virgata</i>			0.11				
<i>Z. clinopodioides</i>			0.06				
<i>C. bijarensis</i>			0.03				
<i>B. multifida</i>			0.01				
<i>S. inflata</i>			0.01				
<i>C. robustus</i>			0.05				
<i>E. billardieri</i>			0.04				
<i>C. juncea</i>			0.004				
<i>Cousinia sp.</i>			0.21				
<i>S. orientalis</i>			0.12				
<i>C. congestum</i>			0.11				
<i>C. botrys</i>			0.04				
<i>S. barbata</i>			0.18				
<i>A. verus</i>			0.07				
<i>H. speciosum</i>			0.04				

Species	Enrichment Coefficient (EC)						
	Pb	Ni	Zn	Al	Cr	As	Cd
<b>Case Study: Gangwon, Korea</b>							
<b>Reference: Usman <i>et al.</i>, 2012</b>							
<i>Artemisia princeps</i> Pamp.					0.33	0.21	
<i>Aster koraiensis</i>					0.06	0.25	
<i>Chelidonium majus</i>					0.06	0.1	
<i>Duchesnea chrysantha</i>					0.28	0.48	
<i>Equisetum arvense</i> L.					0.44	0.05	
<i>Erigeron canadensis</i> L.					0.1	0.47	
<i>Glycine soja</i>					0	0	
<i>Iris ensata</i>					22.1	0	
<i>Lactuca indica</i> L.					0.09	0.18	
<i>Mentha arvense</i> L.					0.33	0.35	
<i>Oenanthe javanica</i>					0.43	0	
<i>Persicaria thunbergii</i>					0.03	0.17	
<i>Phragmites communis</i>					0.18	0.02	
<i>Plantago depressa</i> Willd.					0.03	0.01	
<i>Scirpus fluviatilis</i>					0	0.02	
<i>Scirpus radicans</i> Schk.					0.04	3.23	
<i>Scirpus tabernaemontani</i>					0.06	0.06	
<i>Typha orientalis</i>					27.9	0	
<i>Zizania latifolia</i>					0.04	0	

Species	Enrichment Coefficient (EC)						
	Pb	Ni	Zn	Al	Cr	As	Cd
<b>Case Study: Mediterranean climate</b>							
<b>Reference: Branqhino <i>et al.</i>, 2007</b>							
<i>Plantago almogravensis</i> Franco				0.18			

# ANNEX III

## System dynamics model

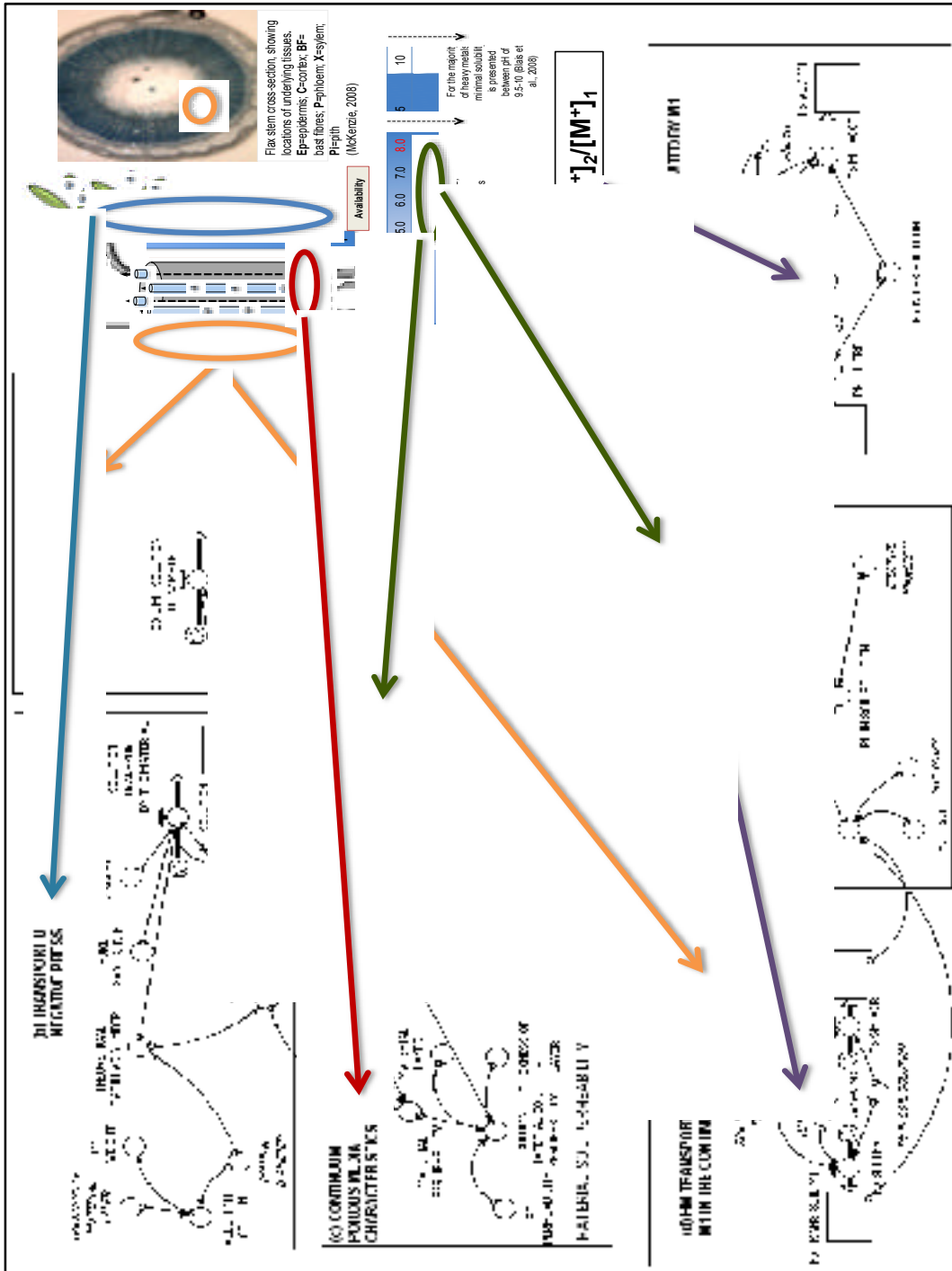

### System dynamics model equations

- $AL\_ACC\_M1(t) = AL\_ACC\_M1(t - dt) + (AL\_M1\_ACCR) * dt$   
 INIT  $AL\_ACC\_M1 = 0$  (mg)  
 INFLOWS:  
 \*  $AL\_M1\_ACCR = M1\_SOLUTION\_FLOW\_RATE * AL\_IN\_LAB\_SOLUTION * AC\_Al * (1/1000)$   
 (mL/h\*mgAl/L\*TF\*1L/1000mL: final units mgAl/h)
- $AL\_ACC\_SOIL\_M1(t) = AL\_ACC\_SOIL\_M1(t - dt) + (AL\_SM\_ACR) * dt$   
 INIT  $AL\_ACC\_SOIL\_M1 = 0$  (mg)  
 INFLOWS:  
 \*  $AL\_SM\_ACR = AL\_IN\_SOIL\_SOLUTION * SOIL\_M1\_SOLUTION\_FLOW\_RATE * AC\_Al * (1/1000)$   
 (mL/h\*mgAl/L\*AC\*1L/1000mL: final units mgAl/h)
- $AL\_TRANS\_M1(t) = AL\_TRANS\_M1(t - dt) + (AL\_M1\_TRR) * dt$   
 INIT  $AL\_TRANS\_M1 = 0$  (mg)  
 INFLOWS:  
 \*  $AL\_M1\_TRR = M1\_SOLUTION\_FLOW\_RATE * AL\_IN\_LAB\_SOLUTION * TC\_AL\_M1 * (1/1000)$   
 (mL/h\*mgAl/L\*TF\*1L/1000mL: final units mgAl/h)
- $AL\_TRANS\_SOIL\_M1(t) = AL\_TRANS\_SOIL\_M1(t - dt) + (AL\_SM\_TRR) * dt$   
 INIT  $AL\_TRANS\_SOIL\_M1 = 0$  (mg)  
 INFLOWS:  
 \*  $AL\_SM\_TRR = AL\_IN\_SOIL\_SOLUTION * SOIL\_M1\_SOLUTION\_FLOW\_RATE * TC\_AL\_M1 * (1/1000)$   
 (mL/h\*mgAl/L\*TF\*1L/1000mL: final units mgAl/h)
- $Cd\_ACC\_M1(t) = Cd\_ACC\_M1(t - dt) + (Cd\_M\_ACCR) * dt$   
 INIT  $Cd\_ACC\_M1 = 0$  (mg)  
 INFLOWS:  
 \*  $Cd\_M\_ACCR = M1\_SOLUTION\_FLOW\_RATE * Cd\_IN\_LAB\_SOLUTION * AC\_Cd * (1/1000)$   
 (mL/h\*mgCd/L\*TF\*1L/1000mL: final units mgCd/h)
- $Cd\_ACC\_SOIL\_M1(t) = Cd\_ACC\_SOIL\_M1(t - dt) + (Cd\_SM\_ACR) * dt$   
 INIT  $Cd\_ACC\_SOIL\_M1 = 0$  (mg)  
 INFLOWS:  
 \*  $Cd\_SM\_ACR = Cd\_IN\_SOIL\_SOLUTION * SOIL\_M1\_SOLUTION\_FLOW\_RATE * AC\_Cd * (1/1000)$   
 (mL/h\*mgCd/L\*AC\*1L/1000mL: final units mgCd/h)
- $Cd\_TRANS\_M1(t) = Cd\_TRANS\_M1(t - dt) + (Cd\_M\_TRR) * dt$   
 INIT  $Cd\_TRANS\_M1 = 0$  (mg)  
 INFLOWS:  
 \*  $Cd\_M\_TRR = M1\_SOLUTION\_FLOW\_RATE * Cd\_IN\_LAB\_SOLUTION * TC\_Cd\_M1 * (1/1000)$   
 (mL/h\*mgCd/L\*TF\*1L/1000mL: final units mgCd/h)
- $Cd\_TRANS\_SOIL\_M1(t) = Cd\_TRANS\_SOIL\_M1(t - dt) + (Cd\_SM\_TRR) * dt$   
 INIT  $Cd\_TRANS\_SOIL\_M1 = 0$  (mg)  
 INFLOWS:  
 \*  $Cd\_SM\_TRR = Cd\_IN\_SOIL\_SOLUTION * SOIL\_M1\_SOLUTION\_FLOW\_RATE * TC\_Cd\_M1 * (1/1000)$   
 (mL/h\*mgCd/L\*TF\*1L/1000mL: final units mgCd/h)
- $Cr\_ACC\_M1(t) = Cr\_ACC\_M1(t - dt) + (Cr\_M1\_ACCR) * dt$   
 INIT  $Cr\_ACC\_M1 = 0$  (mg)  
 INFLOWS:  
 \*  $Cr\_M1\_ACCR = M1\_SOLUTION\_FLOW\_RATE * Cr\_IN\_LAB\_SOLUTION * AC\_Cr * (1/1000)$   
 (mL/h\*mgCr/L\*TF\*1L/1000mL: final units mgCr/h)
- $Cr\_ACC\_SOIL\_M1(t) = Cr\_ACC\_SOIL\_M1(t - dt) + (Cr\_SM\_ACR) * dt$   
 INIT  $Cr\_ACC\_SOIL\_M1 = 0$  (mg)  
 INFLOWS:  
 \*  $Cr\_SM\_ACR = Cr\_IN\_SOIL\_SOLUTION * SOIL\_M1\_SOLUTION\_FLOW\_RATE * AC\_Cr * (1/1000)$   
 (mL/h\*mgCr/L\*AC\*1L/1000mL: final units mgCr/h)
- $Cr\_TRANS\_M1(t) = Cr\_TRANS\_M1(t - dt) + (Cr\_M1\_TRR) * dt$   
 INIT  $Cr\_TRANS\_M1 = 0$  (mg)  
 INFLOWS:  
 \*  $Cr\_M1\_TRR = M1\_SOLUTION\_FLOW\_RATE * Cr\_IN\_LAB\_SOLUTION * TC\_Cr\_M1 * (1/1000)$   
 (mL/h\*mgCr/L\*TF\*1L/1000mL: final units mgCr/h)
- $Cr\_TRANS\_SOIL\_M1(t) = Cr\_TRANS\_SOIL\_M1(t - dt) + (Cr\_SM\_TRR) * dt$   
 INIT  $Cr\_TRANS\_SOIL\_M1 = 0$  (mg)  
 INFLOWS:  
 \*  $Cr\_SM\_TRR = Cr\_IN\_SOIL\_SOLUTION * SOIL\_M1\_SOLUTION\_FLOW\_RATE * TC\_Cr\_M1 * (1/1000)$   
 (mL/h\*mgCr/L\*TF\*1L/1000mL: final units mgCr/h)
- $NL\_ACC\_M1(t) = NL\_ACC\_M1(t - dt) + (NL\_M1\_ACCR) * dt$   
 INIT  $NL\_ACC\_M1 = 0$  (mg)

```

INFLOWS:
  => NI_M1_ACCR = M1_SOLUTION_FLOW_RATE*NI_IN_LAB_SOLUTION*AC_NI*(1/1000)
      (mL/h*mgNi/L*TF*1L/1000mL: final units mgNi/h)
 NI_ACC_SOIL_M1(t) = NI_ACC_SOIL_M1(t - dt) + (NI_SM_ACR) * dt
INIT NI_ACC_SOIL_M1 = 0 (mg)
INFLOWS:
  => NI_SM_ACR = NI_IN_SOIL_SOLUTION*SOIL_M1_SOLUTION_FLOW_RATE*AC_NI*(1/
      1000) (mL/h*mgNi/L*AC*1L/1000mL: final units mgNi/h)
 NI_TRANS_SOIL_M1(t) = NI_TRANS_SOIL_M1(t - dt) + (NI_SM_TRR) * dt
INIT NI_TRANS_SOIL_M1 = 0 (mg)
INFLOWS:
  => NI_SM_TRR = NI_IN_SOIL_SOLUTION*SOIL_M1_SOLUTION_FLOW_RATE*TC_NI_M1*(1/
      1000) (mL/h*mgNi/L*TF*1L/1000mL: final units mgNi/h)
 NI_TRANS_M1(t) = NI_TRANS_M1(t - dt) + (NI_M1_TRR) * dt
INIT NI_TRANS_M1 = 0 (mg)
INFLOWS:
  => NI_M1_TRR = M1_SOLUTION_FLOW_RATE*NI_IN_LAB_SOLUTION*TC_NI_M1*(1/1000)
      (mL/h*mgNi/L*TF*1L/1000mL: final units mgNi/h)
 Pb_ACC_M1(t) = Pb_ACC_M1(t - dt) + (Pb_M1_ACCR) * dt
INIT Pb_ACC_M1 = 0 (mg)
INFLOWS:
  => Pb_M1_ACCR = M1_SOLUTION_FLOW_RATE*Pb_IN_LAB_SOLUTION*AC_Pb_M1*(1/
      1000) (mL/h*mgPb/L*TF*1L/1000mL: final units mgPb/h)
 Pb_ACC_SOIL_M1(t) = Pb_ACC_SOIL_M1(t - dt) + (Pb_SM_ACR) * dt
INIT Pb_ACC_SOIL_M1 = 0 (mg)
INFLOWS:
  => Pb_SM_ACR = Pb_IN_SOIL_SOLUTION*SOIL_M1_SOLUTION_FLOW_RATE*AC_Pb_M1*
      (1/1000) (mL/h*mgPb/L*AC*1L/1000mL: final units mgPb/h)
 Pb_TRANS_M1(t) = Pb_TRANS_M1(t - dt) + (Pb_M1_TRR) * dt
INIT Pb_TRANS_M1 = 0 (mg)
INFLOWS:
  => Pb_M1_TRR = M1_SOLUTION_FLOW_RATE*Pb_IN_LAB_SOLUTION*TC_Pb_M1*(1/
      1000) (mL/h*mgPb/L*TF*1L/1000mL: final units mgPb/h)
 Pb_TRANS_SOIL_M1(t) = Pb_TRANS_SOIL_M1(t - dt) + (Pb_SM_TRR) * dt
INIT Pb_TRANS_SOIL_M1 = 0 (mg)
INFLOWS:
  => Pb_SM_TRR = Pb_IN_SOIL_SOLUTION*SOIL_M1_SOLUTION_FLOW_RATE*TC_Pb_M1*
      (1/1000) (mL/h*mgPb/L*TF*1L/1000mL: final units mgPb/h)
 SOLUTION_TRANSPORTED_BY_SOIL_M1(t) = SOLUTION_TRANSPORTED_BY_SOIL_M1(t - dt)
      + (SOIL_M1_SOLUTION_FLOW_RATE) * dt
INIT SOLUTION_TRANSPORTED_BY_SOIL_M1 = 0(cm^3)
INFLOWS:
  => SOIL_M1_SOLUTION_FLOW_RATE = COLUMN_MATERIAL_SOIL_PERMEABILITY*
      SUCTION_PRESSURE*101.97*CAPILLAR_AREA *1000000 (column permeability soil-
      material m/h * water potential NPa/m * 101.97 m of water/1NPa equivalent to
      eliminate units * capillary area in m^2 * 1000000cm^3/m^3: final units cm^3/h)
 SOLUTION_TRANSPORT_BY_THE_MATERIAL(t) =
      SOLUTION_TRANSPORT_BY_THE_MATERIAL(t - dt) + (M1_SOLUTION_FLOW_RATE) * dt
INIT SOLUTION_TRANSPORT_BY_THE_MATERIAL = 0 (cm^3)
INFLOWS:
  => M1_SOLUTION_FLOW_RATE = (3.1416*PORE_MATERIAL_RADIUS^4/(0*
      WATER_VISCOSITY))*SUCTION_PRESSURE*THEORETICAL_CAPILLAR_NUMBER *
      3600*1000000 (3600s/h*1000000cm^3/m^3*average number of capillary tubes
      cm^3/h to number of capillary tubes obtained to cellulose material)
 Zn_ACC_M1(t) = Zn_ACC_M1(t - dt) + (Zn_M1_ACCR) * dt
INIT Zn_ACC_M1 = 0 (mg)
INFLOWS:
  => Zn_M1_ACCR = M1_SOLUTION_FLOW_RATE*Zn_IN_LAB_SOLUTION*AC_Zn*(1/1000)
      (mL/h*mgZn/L*TF*1L/1000mL: final units mgZn/h)
 Zn_ACC_SOIL_M1(t) = Zn_ACC_SOIL_M1(t - dt) + (Zn_SM_ACR) * dt
INIT Zn_ACC_SOIL_M1 = 0 (mg)

```

- INFLOWS:
- ☑  $Zn\_M1\_TRR = M1\_SOLUTION\_FLOW\_RATE * Zn\_IN\_LAB\_SOLUTION * TC\_Zn\_M1 * (1/1000)$   
(mL/h\*mgZn/L\*TF\*1L/1000mL: final units mgZn/h)
  - $Zn\_TRANS\_SOIL\_M1(t) = Zn\_TRANS\_SOIL\_M1(t - dt) + (Zn\_SM\_TRR) * dt$
  - INIT  $Zn\_TRANS\_SOIL\_M1 = 0$  (mg)
- INFLOWS:
- ☑  $Zn\_SM\_TRR = Zn\_IN\_SOIL\_SOLUTION * SOIL\_M1\_SOLUTION\_FLOW\_RATE * TC\_Zn\_M1 * (1/1000)$  (mL/h\*mgZn/L\*TF\*1L/1000mL: final units mgZn/h)
  - $Al\_IN\_LAB\_SOLUTION = 1.5$  (mg/kg)
  - $Al\_in\_soil = 500$  (mg/kg)
  - $Al\_IN\_SOIL\_SOLUTION = ((\Delta Al\_IN\_SOIL * Al\_pH\_MOBILITY/100) * SOIL\_MASS) / ((EFFECTIVE\_POROSITY * VOLUMEN\_SOIL\_COLUMN * 10) * 1000)$  (mg/kg of heavy metal in soil \* % of heavy metal mobility in the soil \* soil mass in the column in kg / soil volumen in the column in m<sup>3</sup>\*(1 m<sup>3</sup>/1000 L); final units: mg/L of metal)
  - $CAPILLAR\_AREA = 3.1416 * (0.00001^2) * THEORETICAL\_CAPILLAR\_NUMBER (P) \times$  capillary radius  $n =$  average number of capillary tubes)
  - $Cd\_IN\_LAB\_SOLUTION = 1.5$  (mg/kg)
  - $Cd\_in\_soil = 345$  (mg/kg)
  - $Cd\_IN\_SOIL\_SOLUTION = ((\Delta Cd\_IN\_SOIL * Cd\_pH\_MOBILITY/100) * SOIL\_MASS) / ((EFFECTIVE\_POROSITY * VOLUMEN\_SOIL\_COLUMN * 10) * 1000)$  (mg/kg of heavy metal in soil \* % of heavy metal mobility in the soil \* soil mass in the column in kg / soil volumen in the column in m<sup>3</sup>\*(1 m<sup>3</sup>/1000 L); final units: mg/L of metal)
  - $COLUMN\_DIAMETER = 0.008$  (m)
  - $COLUMN\_MATERIAL\_SOIL\_PERMEABILITY = ((LONG\_MATERIAL + LONG\_SOIL) / ((LONG\_MATERIAL / MATERIAL\_PERMEABILITY) + (LONG\_SOIL / SOIL\_PERMEABILITY))) * 100$  (cm/R total permeability of layers soil-material)
  - $Cr\_IN\_LAB\_SOLUTION = 1.5$  (mg/kg)
  - $Cr\_in\_soil = 3950$  (mg/kg)
  - $Cr\_IN\_SOIL\_SOLUTION = ((\Delta Cr\_IN\_SOIL * Cr\_pH\_MOBILITY/100) * SOIL\_MASS) / ((EFFECTIVE\_POROSITY * VOLUMEN\_SOIL\_COLUMN * 10) * 1000)$  (mg/kg of heavy metal in soil \* % of heavy metal mobility in the soil \* soil mass in the column in kg / soil volumen in the column in m<sup>3</sup>\*(1 m<sup>3</sup>/1000 L); final units: mg/L of metal)
  - $EFFECTIVE\_POROSITY = 0.50$  (% of porous saturated of water)
  - $HM\_IN\_SOIL\_SOLUTION = ((SOIL\_MASS * \Delta Zn\_IN\_SOIL * Zn\_pH\_MOBILITY/100) + (SOIL\_MASS * \Delta Ni\_IN\_SOIL * Ni\_pH\_MOBILITY/100) + (SOIL\_MASS * \Delta Cr\_IN\_SOIL * Cr\_pH\_MOBILITY/100) + (SOIL\_MASS * \Delta Al\_IN\_SOIL * Al\_pH\_MOBILITY/100) + (SOIL\_MASS * \Delta Pb\_IN\_SOIL * Pb\_pH\_MOBILITY/100) + (SOIL\_MASS * \Delta Cd\_IN\_SOIL * Cd\_pH\_MOBILITY/100)) / ((EFFECTIVE\_POROSITY * VOLUMEN\_SOIL\_COLUMN * 10) * 1000)$  (mg/kg of heavy metal in soil \* % of heavy metal mobility in the soil \* soil mass in the column in kg / soil volumen in the column in m<sup>3</sup>\*(1 m<sup>3</sup>/1000 L); final units: mg/L of metal)
  - $LONG\_COLUMN\_OF\_SOIL = 0.30$  (m)
  - $LONG\_MATERIAL = 0.3$  (m)
  - $LONG\_SOIL = 0.3$  (m)
  - $M1\_WEIGHT = VOLUMEN\_M1\_COLUMN * 0.0024 / 0.00001507$  (m<sup>3</sup> of column\*0.0024kg of M2/0.00001507 m<sup>3</sup> of the column used in the laboratory)
  - $MATERIAL\_PERMEABILITY = ((M1\_SOLUTION\_FLOW\_RATE * (1/1000000)) / (SUCTION\_PRESSURE) * 1 / (101.97 * CAPILLAR\_AREA))$  (m/s, at pH=4 to M1)
  - $Ni\_IN\_LAB\_SOLUTION = 1.5$  (mg/L)
  - $Ni\_in\_soil = 4500$  (mg/kg)
  - $Ni\_IN\_SOIL\_SOLUTION = ((\Delta Ni\_IN\_SOIL * Ni\_pH\_MOBILITY/100) * SOIL\_MASS) / ((EFFECTIVE\_POROSITY * VOLUMEN\_SOIL\_COLUMN * 10) * 1000)$  (mg/kg of heavy metal in soil \* % of heavy metal mobility in the soil \* soil mass in the column in kg / soil volumen in the column in m<sup>3</sup>\*(1 m<sup>3</sup>/1000 L); final units: mg/L of metal)
  - $Pb\_IN\_LAB\_SOLUTION = 1.5$  (mg/L)
  - $Pb\_in\_soil = 6900$  (mg/kg)
  - $Pb\_IN\_SOIL\_SOLUTION = ((\Delta Pb\_IN\_SOIL * Pb\_pH\_MOBILITY/100) * SOIL\_MASS) / ((EFFECTIVE\_POROSITY * VOLUMEN\_SOIL\_COLUMN * 10) * 1000)$  (mg/kg of heavy metal in soil \* % of heavy metal mobility in the soil \* soil mass in the column in kg / soil volumen in the column in m<sup>3</sup>\*(1 m<sup>3</sup>/1000 L); final units: mg/L of metal)
  - $PORE\_MATERIAL\_RADIUS = 0.00001$  (m)
  - $SOIL\_MASS = VOLUMEN\_SOIL\_COLUMN * 2650$  (Volumen of the column m<sup>3</sup> x apparent density of the soil kg/m<sup>3</sup>: final units kg for soil in the column)
  - $SOIL\_PERMEABILITY = 0.008$  (m/h clay-loam soil)



- SUCTION\_PRESSURE = 0,02 ( MPa/m)
- THEORETICAL\_CAPILLAR\_NUMBER = COLUMN\_DIAMETER\*200000/COLUMN\_DIAMETER
- VOLUMEN\_SOIL\_COLUMN = 3,1416\*((COLUMN\_DIAMETER/2)^2)\*LONG\_COLUMN\_OF\_SOIL ( tube area= 3,1416x0,004^2 m^2 of diameter x length of 0,30 m; final units m^3)
- VOLUM\_M1\_COLUMN = 3,1416\*((COLUMN\_DIAMETER/2)^2)\*LONG\_MATERIAL (tube area = 3,1416x0,004^2 m^2 of diameter x length of 0,30 m; final units m^3)
- WATER\_VISCOSITY = 0,000000001 ( MPa s)
- Zn\_IN\_LAB\_SOLUTION = 1,5 (mg/L)
- Zn\_in\_soil = 5000 (mg/kg)
- Zn\_IN\_SOIL\_SOLUTION = ((ΔZn\_IN\_SOIL\*Zn\_pH\_MOBILITY/100)\*SOIL\_MASS)/ ((EFFECTIVE\_POROSITY\*VOLUMEN\_SOIL\_COLUMN\*10)\*1000) (mg/kg of heavy metal in soil \* % of heavy metal mobility in the soil \* soil mass in the column in kg / soil volumen in the column in m^3\*(1 m^3/1000 L); final units: mg/L of metal)
- ΔAl\_IN\_SOIL = (Al\_in\_soil\*SOIL\_MASS)-(Al\_TRANS\_SOIL\_M1+Al\_ACC\_SOIL\_M1) (mg/kg of soil-mg transported by the column)
- ΔCd\_IN\_SOIL = (Cd\_in\_soil\*SOIL\_MASS)-(Cd\_TRANS\_SOIL\_M1+Cd\_ACC\_SOIL\_M1) (mg/kg of soil-mg transported by the column)
- ΔCr\_IN\_SOIL = (Cr\_in\_soil\*SOIL\_MASS)-(Cr\_TRANS\_SOIL\_M1+Cr\_ACC\_SOIL\_M1) (mg/kg of soil-mg transported by the column)
- ΔNi\_IN\_SOIL = (Ni\_in\_soil\*SOIL\_MASS)-(Ni\_TRANS\_SOIL\_M1+Ni\_ACC\_SOIL\_M1) (mg of soil-mg transported by the column)
- ΔPb\_IN\_SOIL = (Pb\_in\_soil\*SOIL\_MASS)-(Pb\_TRANS\_SOIL\_M1+Pb\_ACC\_SOIL\_M1) (mg/kg of soil-mg transported and accumulated by the column)
- ΔZn\_IN\_SOIL = (Zn\_in\_soil\*SOIL\_MASS)-(Zn\_TRANS\_SOIL\_M1+Zn\_ACC\_SOIL\_M1) (mg/kg of soil-mg transported by the column)
- AC\_Al = GRAPH(SOIL\_pH)  
(4,00, 0,81), (8,00, 0,35)
- AC\_Cd = GRAPH(SOIL\_pH)  
(4,00, 0,08), (8,00, 0,68)
- AC\_Cr = GRAPH(SOIL\_pH)  
(4,00, 0,42), (8,00, 0,35)
- AC\_Ni = GRAPH(SOIL\_pH)  
(4,00, 0,07), (8,00, 0,38)
- AC\_Pb\_M1 = GRAPH(SOIL\_pH)  
(4,00, 0,76), (8,00, 0,34)
- AC\_Zn = GRAPH(SOIL\_pH)  
(4,00, 0,03), (8,00, 0,39)
- Al\_pH\_MOBILITY = GRAPH(SOIL\_pH)  
(2,00, 95,0), (2,65, 75,0), (3,30, 58,0), (3,95, 45,0), (4,60, 28,0), (5,25, 12,0), (5,90, 10,0), (6,55, 10,0), (7,20, 10,0), (7,85, 10,0), (8,50, 9,50)
- Cd\_pH\_MOBILITY = GRAPH(SOIL\_pH)  
(2,50, 100), (3,10, 89,0), (3,70, 72,0), (4,30, 61,0), (4,90, 48,0), (5,50, 38,0), (6,10, 30,0), (6,70, 17,0), (7,30, 12,0), (7,90, 11,0), (8,50, 10,0)

- Cr\_pH\_MOBILITY = GRAPH(SOIL\_pH)  

(2.00, 95.0), (2.65, 75.0), (3.30, 58.0), (3.95, 45.0), (4.60, 28.0), (5.25, 12.0), (5.90, 10.0), (6.55, 10.0), (7.20, 10.0), (7.85, 10.0), (8.50, 9.50)
- Ni\_pH\_MOBILITY = GRAPH(SOIL\_pH)  

(2.00, 98.0), (2.65, 88.0), (3.30, 75.0), (3.95, 58.0), (4.60, 42.0), (5.25, 30.0), (5.90, 12.0), (6.55, 7.00), (7.20, 5.00), (7.85, 3.00), (8.50, 2.00)
- Pb\_pH\_MOBILITY = GRAPH(SOIL\_pH)  

(2.00, 92.0), (2.65, 68.0), (3.30, 50.0), (3.95, 33.0), (4.60, 15.0), (5.25, 7.50), (5.90, 7.50), (6.55, 7.50), (7.20, 7.40), (7.85, 7.40), (8.50, 7.30)
- SOIL\_pH = GRAPH(TIME)  

(0.00, 8.00), (28.0, 7.50), (56.0, 6.94), (84.0, 6.42), (112, 5.78), (140, 4.66), (168, 4.52), (196, 4.52), (224, 5.00), (252, 6.50), (280, 7.00), (308, 7.00), (336, 7.00)
- TC\_Al\_M1 = GRAPH(SOIL\_pH)  

(4.00, 0.08), (8.00, 0.00)
- TC\_Cd\_M1 = GRAPH(SOIL\_pH)  

(4.00, 0.99), (8.00, 0.01)
- TC\_Cr\_M1 = GRAPH(SOIL\_pH)  

(4.00, 0.55), (8.00, 0.00)
- TC\_Ni\_M1 = GRAPH(SOIL\_pH)  

(4.00, 1.00), (8.00, 0.00)
- TC\_Pb\_M1 = GRAPH(SOIL\_pH)  

(4.00, 0.1), (8.00, 0.00)
- TC\_Zn\_M1 = GRAPH(SOIL\_pH)  

(4.00, 0.99), (8.00, 0.00)
- Zn\_pH\_MOBILITY = GRAPH(SOIL\_pH)  

(2.00, 98.0), (2.65, 88.0), (3.30, 75.0), (3.95, 58.0), (4.60, 42.0), (5.25, 30.0), (5.90, 12.0), (6.55, 7.00), (7.20, 5.00), (7.85, 3.00), (8.50, 2.00)

## BIBLIOGRAPHY

- Abhilash, P. C., Pandey, V. C., Srivastava, P., Rakesh, P. S., Chandran, S., Singh, N., Thomas, A.P. (2009). *Phytofiltration of Cadmium from Water by Limnocharis flava (L.) Buchenau Grown in Free-floating Culture System*. Journal of Hazardous Materials 170(2-3), 791-797.
- Adriano, D. C. (2001). *Trace elements in Terrestrial Environments. Biogeochemistry, Bioavailability and Risks of Metals*. Second ed., Springer-Verlag, New York, p. 867.
- Alkorta, I., Garbisu, C. (2001). *Phytoremediation of Organic Contaminants in Soils*. Bioresource Technology 79(3), 273-276.
- Alkorta, I., Hernandez-Allica, J., Garbisu, C. (2004). *Plants Against the Global Epidemic of Arsenic Poisoning*. Environment International 30(7), 949-951.
- Alloway, B. J. (1995). *Heavy Metals in Soils*. Second ed., Blackie Academic & Professional, Glasgow, UK, p. 368.
- Alloway, B. J., Jackson, A. P. (1991). *The Behaviour of Heavy metals in Sewage Sludge-Amended Soils*. Science of the Total Environment 100, 151-176.
- Anawar, H. M., Alam, M. T., Maijibur, M. (2008). *Phytofiltration of Water Polluted with Arsenic and Heavy Metals*. International Journal of Environment and Pollution 33(2-3), 292-312.
- Anawar, H. M., Garcia-Sanchez, A., Murciego, A., Buyolo, T. (2006). *Exposure and Bioavailability of Arsenic in Contaminated Soils from the La Parrilla Mine, Spain*. Environmental Geology 50(2), 170-179.
- Appenroth, K. J. (2010). *Definition of Heavy Metals and Their Role in Biological Systems*. In: I. Sherameti, A. Varma (Eds.), Soil Heavy Metals. Springer-Verlag, Berlin Heidelberg, p. 19-29.
- Baker, A. J. M. (1981). *Accumulators and Excluders: Strategies in the Response of Plants to Trace Metals*. Journal of Plant Nutrition 3, 643-654.
- Baldwin, P. R., Butcher, D. J. (2007). *Phytoremediation of Arsenic by Two Hyperaccumulators in a Hydroponic Environment*. Microchemical Journal, 85(2), 297-300.
- Bar-Cohen, Y. (2006). *Biomimetics: Using Nature to Inspire Human Innovation*. Bioinspiration & Biomimetics 1, 1-12.

- Barceló, J., Poschenrieder, C. (2003). *Phytoremediation: Principles and Perspectives*. Contributions to Science 2(3), 333-344.
- Bech, J., Duran, P., Roca, N., Poma, W., Sánchez, I., Barceló, J., Boluda, R., Roca-Pérez, L., Poschenrieder, C. (2012). *Shoot Accumulation of Several Trace Elements in Native Plant Species from Contaminated Soils in the Peruvian Andes*. Journal of Geochemical Exploration 113, 106-111.
- Belluck, D. A., Benjamin, S. L., David S. (2006). *Why Remediate?* In: G. Echevarria, N. Goncharova, J. L. Morel (Eds.), *Phytoremediation of Metal-contaminated Soils*. Springer-Verlag, Dordrecht, p. 1-23.
- Blais, J. F., Djedidi, Z., Cheikh, R. B., Tyagi, D., Mercier, G. (2008). *Metals Precipitation from Effluents: Review*. Practice Periodical of Hazardous, Toxic and Radioactive Waste Management 12(3), 135-149.
- Blais, J. F., Meunier, N., Mercier, G. (2010). *New Technologies for Toxic Metals Removal from Contaminated Sites*. Recent Patents on Engineering 4(1), 1-6.
- Boer, H. A., Volkov, V. (2003). *Logistics of Water and Salt Transport Through the Plant: Structure and Functioning of the Xylem*. Plant, Cell & Environment 26(1), 87-101.
- Bonser, R. H. (2006). *Patented Biologically-Inspired Technological Innovations: A Twenty Year View*. Journal of Bionic Engineering 3(1), 039-041.
- Bourelleir, P. H., Berthelin, J. (1998). *Contamination des sols par les éléments en traces: Les risques et leur gestion*. Academie des sciences, Paris, p. 438.
- Brankovic, S., Pavlovic-Muratspahic, D., Topuzovic, M., Glisic, R., Bankovic, D., Stankovic, M. (2011). *Environmental Study of Some Metals on Several Aquatic Macrophytes*. African Journal of Biotechnology 19(56), 11956-11965.
- Branquinho, C., Serrano, H., Pinto, M. J., Martins-Loucao, M. A. (2007). *Revisiting the Plant Hyperaccumulation Criteria to Rare Plants and Earth Abundant Elements*. Environmental Pollution 146(1), 437-433.
- Brennan, M. A., Shelley, M. L. (1999). *A Model of the Uptake, Translocation, and Accumulation of Lead (Pb) by Maize for the Purpose of Phytoextraction*. Ecological Engineering 12(3-4), 271-297.
- Brooks, R. R. (1994). *Plants that Hyperaccumulate Heavy Metals*. In: M. E. Farago (Ed.), *Plants and the Chemical Elements: Biochemistry, Uptake, Tolerance and Toxicity*. VCH, Weinheim, Germany, p. 87-106.

- Brooks, R. R., Lee, J., Reeves, R. D., Jaffre, T. (1977). *Detection of Nickeliferous rocks by Analysis of Herbarium Species of Indicator Plants*. Journal of Geochemical Exploration 7, 49-57.
- Brooks, R. R., Robinson, B. H. (1998). *Plants that Hyperaccumulate Heavy Metals: Their Role in Phytoremediation, Microbiology, Archaeology, Mineral Exploration and Phytomining*. CAB International, Oxford, New York, p. 380.
- Butler, R. (2005). *Biomimetics, Technology that Mimics Nature*. [http://news.mongabay.com/2005/0711-rhett\\_butler.html](http://news.mongabay.com/2005/0711-rhett_butler.html). Accessed January 10, 2012.
- Campbell, N. A., Reece, J. B. (2004). *Biology*. Seventh ed., Benjamin Cummings, Brussels, p. 1482.
- Caprette, D. R. (2013). *Student's t Test for Independent Samples*. Experimental Biosciences, Rice University. Resources for Introductory and Intermediate Level Laboratory Courses. <http://www.ruf.rice.edu/~bioslabs/tools/stats/ttest.html>. Accessed May 15, 2013.
- Chao, W., Xiao-Chen, L., Li-Min, Z., Pei-Fang, W., Zhi-Yong, G. (2007). *Pb, Cu, Zn and Ni Concentrations in Vegetables in Relation to Their Extractable Fractions in Soils in Suburban Areas of Nanjing, China*. Polish Journal of Environmental Studies 16(2), 199-207.
- Chatterjee, P. K., Gupta, B. S. (2002). *Absorbent Technology*. First ed., Elsevier Amsterdam, Boston, London, New York, Oxford, Paris, p. 501.
- Chen, Y. X., Lin, Q., Luo, Y. M., GHe, Y. F., Zhen, S. J., Yu, Y. L., Tian, G. M., Wong, M. H. (2003). *The role of Citric Acid on the Phytoremediation of Heavy Metal Contaminated Soil*. Chemosphere 50(6), 807-811.
- Chojnacka, K., Chojnacki, A., Górecka, H., Górecki, H. (2005). *Bioavailability of Heavy Metals from Polluted Soils to Plants*. Science of the Total Environment 337 (1-3), 175-182.
- Clemens, S., Palmgren, M., Krämer, U. (2002). *A Long Way Ahead: Understanding and Engineering Plant Metal Accumulation*. Trends in Plant Science 7(1), 309-315.
- Cui, S., Zhou, Q., Chao, L. (2007). *Potential Hyperaccumulation of Pb, Zn, Cu and Cd in Endurant Plants Distributed in an Old Smeltery, Northeast China*. Engineering Geology 51(1), 1043-1048.
- Cunningham, S. D., Berti, W. R., Huang, J. W. W. (1995). *Phytoremediation of Contaminated Soils*. Trends in Biotechnology 13(9), 393-397.

- Dayan, A. D., Paine, A. J. (2001). *Mechanisms of Chromium Toxicity, Carcinogenicity and Allergenicity: Review of the Literature from 1985 to 2000*. Human Experimental Toxicology 20(9), 439-451.
- De Boer, A. H., Volkov, V. (2003). *Logistics of Water and Salt Transport Through the Plant: Structure and Functioning of Xylem*. Plant, Cell & Environment 26(1), 87-101.
- Denkhaus, E., Salnikow, K. (2002). *Nickel Essentiality, Toxicity, and Carcinogenicity*. Critical Reviews in Oncology Hematology 42(1), 35-56.
- Dermont, G., Bergeron, M., Mercier, G., Laflèche-Richer, M. (2008). *Metal-Contaminated Soils: Remediation Practices and Treatment Technologies*. Practice Periodical of Hazardous, Toxic and Radioactive Waste Management 12(3), 188-209.
- Dudka, S., Miller, P. (1999). *Accumulation of Potentially Toxic Elements in Plants and Their Transfer to Human Food Chain*. Journal of Environmental Science and Health, Part B: Pesticides, Food Contaminants, and Agricultural Wastes 34(4), 681-708.
- Dumas, E., Laforest, V., De Roy, M., Forano, C., Bourgois, J. (2012). *PCB Adsorption by Organomodified LDH Phases*. Proceedings of the Water, Wastes and Sustainable Development Seminar, Agadir, Morocco, March 21-24, 2012. (Adsorption de PCB par des Phases HDL Organomodifiées. Colloque Eau, Déchets et Développement Durable, Agadir, Maroc, 21-24 mars 2012.)
- Duruibe, J. O., Ogwuegbu, M. O. C., Egwurugwu, J. N. (2007). *Heavy Metal Pollution and Human Biotoxic Effects*. International Journal of Physical Sciences 2(5), 112-118.
- Efstathiou, C. E. (2013). *Student's t-Test: Comparison fo two means*. Department of Chemistry, University of Athens. [http://www.chem.uoa.gr/applets/AppletTtest/App1\\_Ttest2.html](http://www.chem.uoa.gr/applets/AppletTtest/App1_Ttest2.html). Accessed May 15, 2013.
- Environment Canada (2000). *Proceedings of the second phytoremediation technical seminar*. Vancouver, BC, June 13, 2000.
- Environment Canada (2003). *Phytorem - Potential Green Solutions for Metal Contaminated Sites*. <http://www.ec.gc.ca/Publications/default.asp?lang=En&xml=B8A7B13F-FF7B-4375-BBAF-2DE33346C127>. Accessed June 11, 2011.
- Environment Canada (2012). *Technical Assistance Bulletin # 22, In-Situ Remediation Technologies for Contaminated Sites*. <http://www.on.ec.gc.ca/pollution/ecnpd/tabs/tab22-e.html>. Accessed December 08, 2012.
- Ernst, W. H. (2005). *Phytoextraction of Mine Wastes - Options and Impossibilities*. Chemie der Erde Geochemistry 65(S1), 29-42.

- Ernst, W. H. (1996). *Bioavailability of Heavy Metals and Decontamination of Soils by Plants*. Applied Geochemistry 11(1-2), 163-167.
- Fellet, G., Marchiol, L., Perosa, D., Zerbi, G. (2007). *The Application of Phytoremediation Technology in a Soil Contaminated by Pyrite Cinders*. Ecological Engineering 31(3), 207-214.
- Feng, D., Aldrich, C., Tan, H. (2000). *Treatment of Acid Mine Water by Use of Heavy Metal Precipitation and Ion Exchange*. Minerals Engineering 13(6), 623-642.
- Fritioff, A., Greger, M. (2003). *Aquatic and Terrestrial Plant Species with Potential to Remove Heavy Metals from Stormwater*. International Journal of Phytoremediation 5(3), 211-224.
- Garbisu, C., Alkorta, I. (2001). *Phytoextraction: a Cost-Effective Plant-Based Technology for the Removal of Metals from the Environment*. Bioresource Technology 77(3), 229-236.
- Gérente, C., Couespel du Mesnil, P., Andrès, Y., Thibault, J.-F., Le Cloirec, P. (2000). *Removal of Metal Ions from Aqueous Solution on Low Cost Natural Polysaccharides. Sorption Mechanisms Approach*. Reactive and Functional Polymers 46(2), 135-144.
- Ghorbani, H. (2008). *Factors Controlling the Bioavailability of Potentially Harmful Metals in Wastewater Treated Soils*. Proceedings of the International Meeting on Soil Fertility Land Management and Agroclimatology, Kusadasi, Turkey, October 29-31, 2008, p. 987-996.
- Ghosh, M., Singh, S. P. (2005a). *A Comparative Study of Cadmium Phytoextraction by Accumulator and Weed Species*. Environmental Pollution 133(2), 365-371.
- Ghosh, M., Singh, S. P. (2005b). *A Review on Phytoremediation of Heavy Metals and Utilization of It's by Products*. Asian Journal on Energy and Environment 6(4), 214-231.
- Girard, M. C., Walter, J. C., Berthelin, J., Morel, J. L. (2005). *Soils and Environment: Course, Exercices and Case Studies* (Sols et Environnement : Cours, Exercices et Études de Cas). First ed., Dunod, Paris, p. 816.
- Gisbert, C., Almela, C., Velez, D., Lopez-Moya, J. R., de Haro, A., Serrano, R., Montoro, R., Navarro-Avino, J. (2008). *Identification of as Accumulation Plant Species Growing on Highly Contaminated Soils*. International Journal of Phytoremediation 10(3), 185-196.
- Glick, B. R. (2003). *Phytoremediation: Synergistic Use of Plants and Bacteria to Clean Up the Environment*. Biotechnology Advances 21(5), 383-393.

- Guo, Z., Cao, Y. (2005). *Experimental Studies of Biliquid Capillary Siphons*. Chemical Engineering Science 60(10), 2621-2626.
- Hacke, U. G., Sperry, J. S., Wheeler, J. K., Castro, L. (2006). *Scaling of Angiosperm Xylem Structure with Safety and Efficiency*. Tree Physiology 26(6), 689-701.
- Haque, N., Peralta-Videa, J. R., Jones, G. L., Gill, T. E., Gardea-Torresdey, J. L. (2008). *Screening the Phytoremediation Potential of Desert Broom (Baccharis sarothroides Gray) Growing on Mine Tailings in Arizona, USA*. Environmental Pollution 153(2), 362-368.
- Harper, J. L. (1977). *Population Biology of Plants*. First ed., Academic Press, New York, p. 900.
- He, Z. L. L., Yang, X. E., Stoffella, P. J. (2005). *Trace Elements in Agroecosystems and Impacts on the Environment*. Journal of Trace Elements in Medicine and Biology 19(2-3), 125-140.
- Hegazy, A. K., Abdel-Ghani, N. T., El-Chaghaby, G. A. (2011). *Phytoremediation of Industrial Wastewater Potentiality by Typha domingensis*. International Journal of Environment Science and Technology 8(3), 639-648.
- Helms, M., Vattam, S. S., Goel, A. K. (2009). *Biologically Inspired Design: Process and Products*. Design Studies 30(5), 606-622.
- Hernández-Allica, J., Garbisu, C., Barrutia, O., Becerril, J. M. (2007). *EDTA-Induced Heavy Metal Accumulation and Phytotoxicity in Cardoon Plants*. Environmental and Experimental Botany 60(1), 26-32.
- Hsiu-Chuan, V., C., M.-T., Yuen-Yi, T., Kung-Lin, O. (2006). *Assessment of Heavy Metal Bioavailability in Contaminated Sediments and Soils Using Green Fluorescent Protein-based Bacterial Biosensors*. Environmental Pollution 142(1), 17-23.
- Hu, H. (2002). *Human Health and Heavy Metals Exposure*. In: M. McCally (Ed.), Life Support. The Environment and Human Health. MIT Press, USA, p. 65-82.
- January, M., Cutright, T., Van Keulen, H., Wei, R. (2008). *Hydroponic Phytoremediation of Cd, Cr, Ni, As and Fe: Can Helianthus annuus Hyperaccumulate Multiple Heavy Metals?* Chemosphere 70(3), 531-537.
- Jarup, L. (2003). *Hazards of Heavy Metal Contamination*. British Medical Bulletin 68(1), 167-182.
- Kabata-Pendias, A. (2004). *Soil-Plant Transfer of Trace Elements: An Environmental Issue*. Geoderma 122(1), 143-149.



- Kabata-Pendias, A., Mukherjee, A. (2007). *Trace Elements from Soil to Human*. First ed., Springer-Verlag, Berlin Heidelberg, p. 550.
- Kabata-Pendias, A., Pendias, H. (2001). *Trace Elements in Soils and Plants*. Third ed., CRC Press, Boca Raton, London, New York, Washington DC, p. 403.
- Kamal, M., Ghaly, A. E., Mahmoud, N., Côté, R. (2004). *Phytoaccumulation of Heavy Metals by Aquatic Plants*. *Environmental International* 29(8), 1029-1039.
- Kamnev, A. A., Van der Lelie, D. (2000). *Chemical and Biological Parameters as Tools to Evaluate and Improve Heavy Metal Phytoremediation*. *Bioscience Reports* 20(4), 239-258.
- Kashem, M. A., Singh, B. R. (2002). *The effect of Fertilizer Additions on the Solubility and Plant-availability of Cd, Ni and Zn in Soil*. *Nutrient Cycling in Agroecosystems* 62(3), 287-296.
- Kim, I. S., Kang, H. K., Johnson-Green, P., Lee, E. J. (2003). *Investigation of Heavy Metal Accumulation in Polygonum Thunbergii for Phytoextraction*. *Environmental Pollution* 126(1), 235-243.
- Kirkham, M. B. (2006). *Cadmium in Plants on Polluted Soils: Effects of Soil Factors, Hyperaccumulation and Amendments*. *Geoderma* 137(1), 19-32.
- Krämer, U. (2003). *Phytoremediation to Phytochelatin-Plant Trace Metal Homeostasis*. *New Phytologist* 158(1-9), 4-6.
- Krämer, U. (2005). *Phytoremediation: Novel Approaches to Cleaning Up Polluted Soils*. *Current Opinion in Biotechnology* 16(2), 133-141.
- Krishnamurti, G. S. R., Naidu, R. (2008). *Chemical Speciation and Bioavailability of Trace Metals*. In: A. Violante, P. M. Haug, G. M. Gadd (Eds.), *Biophysico-Chemical Processes of Heavy Metals and Metalloids in Soil Environments*. First ed., Wiley Interscience, New Jersey, p. 419-466.
- Kukier, U., Peters, C., Chaney, R. A., Roseberg, J. (2004). *The Effect of pH on Metal Accumulation in Two Alyssum Species*. *Journal of Environmental Quality* 33(1), 2090-2102.
- Kvesitadze, G., Khatisashvili, G., Sadunishvili, T., Ramsden, J. (2006). *Biochemical Mechanisms of Detoxification in Higher Plants: Basis of Phytoremediation*. First ed., Springer-Verlag, Berlin Heidelberg, p. 262.

- Lassat, M. M. (2000). *Phytoextraction of Metals from Contaminated Soil: A Review of Plants/Soil/Metal Interaction and Assessment of Pertinent Agronomic Issues*. Journal of Hazardous Substance Research 2(5), 1-25.
- Lassat, M. M. (2002). *Phytoextraction of Toxic Metals: A Review of Biological Mechanisms*. Journal of Environmental Quality 31(1), 109-120.
- Lattif, A., Karim, A., Ahmad, S., Ridzuan, M., Hung, Y. T. (2012). *Phytoremediation of Metals in Industrial Sludge by Cyperus Kyllingia-Rasiga, Asystassia Intrusa and Scindapus Pictus Var Argyaeus Plant Species*. International Journal of Integrated Engineering 4(2), 1-8.
- Leyval, C., Turnau, K., Haselwandter, K. (1997). *Effect of Heavy Metal Pollution on Mycorrhizal Colonization and Function: Physiological, Ecological and Applied Aspects*. Mycorrhiza 7(1), 139-153.
- Li, Y., Zu, Y., Fang, Q., Gao, Z., Schwartz, C. (2009). *Relationship Between Heavy Metal Concentrations of Herbaceous Plants and Soils at four Pb-Zn Mining Sites in Yunnan, China*. Frontiers of Environmental Science and Engineering in China 3(3), 325-333.
- Liao, X. Y., Chen, T. B., Lei, M., Huang, Z. C., Xiao, X. Y., An, Z. Z. (2004). *Root Distributions and Elemental Accumulations of Chinese Brake (Pteris vittata L.) from As-contaminated Soils*. Plant and Soil 261(1-2), 109-116.
- LoRESTANI, B., Cheraghi, M., Yousefi, N. (2011). *Phytoremediation Potential of Native Plants Growing on a Heavy Metals Contaminated Soil of Copper mine in Iran*. World Academy of Science, Engineering and Technology 77(1), 377-382.
- Lstiburek, J. W. (2007). *Capillary Suction Small Sacrifices*. American Society of Heating, Refrigeration and Air-Conditioning Engineers Journal 49(7), 58-61.
- LübBen, S., Sauerbeck, D. (1991). *The Uptake and Distribution of Heavy Metals by Spring Wheat*. Water, Air and Soil Pollution 57-58(1), 239-247.
- Malarkodi, M. (2007). *Remediation of Metal Contaminated Soils Using Plants - A Review*. Agricultural Reviews 28(2), 107-117.
- Malik, R. N., Husain, S. Z., Nazir, I. (2010). *Heavy Metal Contamination and Accumulation in Soil and Wild Plant Species from Industrial Area of Islamabad, Pakistan*. Pakistan Journal of Botany 42(1), 291-301.
- McGrath, S. P., Zhao, F. J. (2003). *Phytoextraction of Metals and Metalloids from Contaminated Soils*. Current Opinion in Biotechnology 14(3), 277-282.

- McGrath, S. P., Zhao, F. J., Lombi, E. (2002). *Phytoremediation of Heavy Metals, Metalloids and Radionuclides*. *Advanced in Agronomy* 75, 1-56.
- McKenzie, R. (2007). *Stem-histology-cross-section-tag.svg*. <http://commons.wikimedia.org/wiki/File:Stem-histology-cross-section-tag.svg>. Accessed January 10, 2010.
- Miclean, M., Roman, C., Levei, E., Senila, M., Abrahm, B., Cordos, E. (2000). *Heavy Metals Availability for Plants in Mining Area from North-Western Romania*. Proceedings of the 15th International Congress of the International Soil Conservation Organization. Budapest, May 18-23, 2008, p. 340.
- Miranda, L. R., Gomes, L. M., Fernandes, G., Velho, L., Cotta, M., Rossatto, D., Haridasan, M., Franco, C. (2011). *Al-Hyperaccumulator Vochysiaceae from the Brazilian Cerrado Store Aluminum in Their Chloroplasts Without Apparent Damage*. *Environmental and Experimental Botany* 70(1), 37-42.
- Moreno-Jiménez, E., Fresno, E., López, C., Peñalosa, J. M. (2010). *Hydroponics as a valid tool to asses arsenic availability in mine soils*. *Chemosphere* 79(5), 513-517.
- Mudgal, V., Madaan, N., Mudgal, A. (2010). *Heavy Metals in Plants: Phytoremediation: Plants Used to Remediate Heavy Metal Pollution*. *Agriculture and Biology Journal of North America* 1(1), 40-46.
- Mukhtar, S., Bhatti, H., Khalid, M., Ul Haq, A., Shahzad, S. (2010). *Potential of Sunflower (Helianthus Annuus L.) for Phytoremediation of Nickel (Ni) and Lead (Pb) Contaminated Water*. *Pakistan Journal of Botany* 42(6), 4017-4026.
- Mulligan, C. N., Yong, R. N., Gibbs, B. F. (2001a). *An Evaluation of Technologies for the Heavy Metal Remediation of Dredged Sediments*. *Journal of Hazardous Materials* 85(1-2), 145-163.
- Mulligan, C. N., Yong, R. N., Gibbs, B. F. (2001b). *Remediation Technologies for Metal-Contaminated Soils and Groundwater: An Evaluation*. *Engineering Geology* 60(1-4), 193-207.
- Nijsee, J. (2004). *On the Mechanism of Xylem Vessel Length Regulation*. *Plant Physiology* 134(1), 32-34.
- Nikiforova, T. E., Kozlov, V. A. (2010). *Specific Features of Sorption of Heavy Metal Ions by Cellulose-Containing Sorbent from Aqueous Media*. *Russian Journal of Applied Chemistry* 83(10), 1781-1784.
- New Jersey Department of Environmental Protection (NJDEP). (1999). *Guidance for Soil Cleanup Criteria*. <http://www.nj.gov/dep/srp/guidance/scc/>. Accessed July 30, 2012.

- Nriagu, J. O. (2007). *Zinc Toxicity in Humans*. [http://www.extranet.elsevier.com/homepage\\_about/mrwd/nvrn/Zinc%20Toxicity%20in%20Humans.pdf](http://www.extranet.elsevier.com/homepage_about/mrwd/nvrn/Zinc%20Toxicity%20in%20Humans.pdf). Accessed January 11, 2013.
- Objegba, V. J., Fasidi, I. O. (2004). *Accumulation of trace elements by Pistia stratiotes: Implications for Phytoremediation*. *Ecotoxicology* 13(7), 637-646.
- Öztürk, H. B., Vu-Manh, H., Bechtold, T. (2009). *Interaction of Cellulose with Alkali Metal Ions and Complexed Heavy Metals*. *Lenzinger Berichte* 87, 142-150.
- Padmavathiamma, P. K., Li, L. Y. (2007). *Phytoremediation Technology: Hyper-Accumulation Metals in Plants*. *Water Air and Soil Pollution* 184(1-4), 105-126.
- Peijnenbur, W. (2004). *Fate of Contaminants in Soil*. In: P. Doelman, H. J. P. Eijsackers (Eds.), *Vital Soil Function, Value and Properties*. Elsevier, p. 245-280.
- Pilon-Smits, E., Freeman, J. (2006). *Environmental Cleanup Using Plants: Biotechnological Advances and Ecological Considerations*. *Frontiers in Ecology and the Environment* 4(4), 203-201.
- Pulford, I. D., Watson, C. (2003). *Phytoremediation of Heavy Metal-contaminated Land by Trees - A Review*. *Environment International* 29(1), 529-540.
- Rachou, J., Sauvé, S. (2008). *Evaluation of Affinity Constants of Cu, Cd, Ca and H for Active Soil Surfaces for a Solid Phase-Controlled Soil Ligand Model*. *Environmental Chemistry* 5(2), 1448-2517.
- Raskin, I., Ensley, B. D. (2000). *Phytoremediation of Toxic Metals : Using Plants to Clean Up the Environment*. First ed., Wiley, New York, p. 304.
- Reddad, Z., Gérente, C., Andres, Y., Le Cloirec, P. (2002). *Adsorption of Several Metal Ions onto a Low-Cost Biosorbent Kinetic and Equilibrium Studies*. *Environmental Science & Technology* 36(9), 2067-2073.
- Riffat, N. M., Syed, Z. H., Ishfaq, N. (2010). *Heavy Metal Contamination and Accumulation in Soil and Wild Plant Species from Industrial Area of Islamabad, Pakistan*. *Pakistan Journal of Botany* 42(1), 291-301.
- Riley, R. G., Zachara, J. M., Wobber, F. J. (1992). *Chemical Contaminants on DOE Lands and Selection of Contaminant Mixtures for Subsurface Science Research*. U.S. Department of Energy, Office of Energy Research, Subsurface Science Program. <http://www.osti.gov/bridge/servlets/purl/10147081-WqqySl/10147081.pdf>. Accessed November 07, 2012.

- Robinson, B., Grenn, S., Mills, T., Clothier, B., van der Velde, M., Laplane, R., Fung, L., Deurer, M., Husrst, S., Thayalakumaran, T., van den Dijssel, C. (2003). *Phytoremediation: Using Plants as Biopumps to Improve Degraded Environments*. Australian Journal of Soil Research 41(3), 599-611.
- Saeed, A., Akhter, W., Iqbal, M. (2005). *Removal and Recovery of Heavy Metals from Aqueous Solution Using Papaya Wood as a New Biosorbent*. Separation and Purification Technology 45(1), 25-31.
- Sasmaz, A., Sasmaz, M. (2009). *The Phytoremediation Potential for Strontium of Indigenous Plants Growing in a Mining Area*. Environmental and Experimental Botany 67(1), 139-144.
- Schmitt, O. H. (1969). *Some Interesting and Useful Biomimetic Transforms*. Proceedings of the 3rd International Biophysics Congress, Boston, 29 August to 3 September, p. 297.
- Seregin, I. V., Ivanov, V. B. (2001). *Physiological Aspects of Cadmium and Lead Toxic Effects on Higher Plants*. Russian Journal of Plant Physiology 48(4), 523-544.
- Shah, F., Ahmad, N., Masood, K., Peralta-Video, J., Ahmad, F. (2010). *Heavy Metal Toxicity in Plants*. In: M. Ashraf, M. Ozturk, M. S. A. Ahmad (Eds.), Plant Adaptation and Phytoremediation. Springer-Verlag, New York, p. 71-97.
- Sheoran, V., Sheoran, A. S., Poonia, P. (2011). *Role of Hyperaccumulators in Phytoextraction of Metals From Contaminated Mining Sites: A Review*. Critical Reviews in Environmental Science and Technology 41(2), 168-214.
- Singh, R., Dhania, G., Sharma, A., Jaiwal, P. (2007). *Biotechnological Approaches to Improve Phytoremediation Efficiency for Environment Contaminants*. In: S. N. Singh, R. D. Tripathi (Eds.), Environmental Bioremediation Technologies. Springer-Verlag, Berlin, p. 223-258.
- Singh, R., Gautam, N., Mishra, A., Gupta, R. (2011). *Heavy Metals and Living Systems: An Overview*. Indian Journal of Pharmacology 43(3), 246-253.
- Sinha, R., Sunil, H., Tandon, P. (2007). *Phytoremediation: Role of Plants in Contaminated Site Management*. In: S. S. Singh, R. D. Tripathy (Eds.), Environmental Bioremediation Technologies. Springer-Verlag, Berlin, p. 315-330.
- Sperry, J. (2011). *Hydraulics of Vascular Water Transport*. In: W. Przemyslaw (Ed.), Signaling and Communication in Plants. Mechanical Integration of Plant Cells and Plants. Springer-Verlag, Berlin Heidelberg, p. 353-327.

- Sperry, J., Volker, S., Uwe, G. H. (2003). *Xylem Hydraulics and the Soil-Plant-Atmosphere Continuum: Opportunities and Unresolved Issues*. *Agronomy Journal* 95(1), 1362-1370.
- Sun, L., Niu, Z., Sun, T. (2007). *Effects of Amendments of N, P, Fe on Phytoextraction of Cd, Pb, Cu, and Zn in Soil of Zhangshi by Mustard, Cabbage, and Sugar Beet*. *Environmental Toxicology* 22(6), 565-571.
- Taiz, L., Zeiger, E. (2010). *Calculating Velocities of Water Movement in the Xylem and in Living Cells*. *Plant Physiology*, Fifth Online ed. <http://www.plantphys.net>. Accessed October 10, 2011.
- Tangahu, B., Abdullah, S., Barsri, H., Idris, M., Anuar, N., Muchlisin, M. (2011). *A Review on Heavy Metals (As, Pb and Hg) Uptake by Plants Through Phytoremediation*. *International Journal of Chemical Engineering* 2011, 1-31.
- Tavisto, M., Kusima, R., Pasila, A., Hautala, M. (2003). *Wetting and Wicking of Fibre Plant Straw Fractions*. *Industrial Crops and Products* 18(1), 25-35.
- Tlustos, P., Pavlikova, D., Szakova, J., Balik, J. (2002). *Plant Accumulation Capacity for Potentially Toxic Elements*. In: J. L. Morel, G. Echevarria, N. Goncharova (Eds.), *Phytoremediation of Metal-Contaminated Soils*. Springer-Verlag, Amsterdam, p. 347.
- Tobin, J. M., Cooper, D. G., Neufeld, R. J. (1984). *Uptake of Metal Ions by Rhizopus arrhizus Biomass*. *Applied and Environmental Microbiology* 47(4), 821-824.
- Tremel-Schaub, A., Feix, I. (2005). *Soil Contamination. Transfert from Soils to Plants (Contamination des Sols. Transferts des Sols vers les Plantes)*. First ed., EDP Sciences-ADEME Editions, Les Ulis-Angers, p. 413.
- United Nations Environment Programme and Agency for the Environment and Energy Management (UNEP and ADEME). (2006). *Identification and Management of Contaminated Sites. A Methodological Guide*. First ed., ADEME Editions, Paris, p. 117.
- United States Department of Agriculture (USDA). (1998). *Soil Quality Indicators: pH*. Soil Quality Information Sheet of the Natural Resources Conservation Service. <http://soils.usda.gov/sqi/publications/files/indicate.pdf>. Accessed January 25, 2011.
- United States Environmental Protection Agency (USEPA). (2012). *Using Phytoremediation to Clean Up Sites*. <http://www.epa.gov/superfund/accomp/news/phyto.htm>. Accessed October 26, 2012.

- Usman, R. A., Lee, S. S., Award, Y. M., Lim, K. J., Yang, J. E., Ok, Y. S. (2012). *Soil Pollution Assessment and Identification of Hyperaccumulating Plants in Chromated Copper Arsenate (CCA) Contaminated Sites, Korea*. *Chemosphere* 87(8), 872-878.
- Valderrama, A., Tapia, J., Peñailillo, P., Carvajal, D. (2012). *Water Phytoremediation of Cadmium and Copper using Azzolla Filiculoides Lam. in a Hydroponic System*. *Water and Environment Journal*, DOI: 10.1111/wej.12015.
- Vargas-Nieto, C., Carrizao, J. G., Castillo, E. (2011). *A Study of Low-cost Adsorbent Materials for Removing Cr(VI) from Aqueous Waste Effluent*. *Ingeniería e Investigación* 31(1), 154-162.
- Vidali, M. (2001). *Bioremediation. An Overview*. *Pure and Applied Chemistry* 73(7), 1163-1172.
- Vincent, J. F. V., Bogatyreva, O. A., Bogatyrev, N. R., Bowyer, A., Phal, A. K. (2006). *Biomimetics: Its Practice and Theory*. *Journal of the Royal Society Interface* 3(1), 471-482.
- Violante, A., Cozzolino, V., Perelomov, L., Caporale, A. G., Pigna, M. (2010). *Mobility and Bioavailability of Heavy Metals and Metalloids in Soil Environments*. *Journal of Soil Science and Plant Nutrition* 10(3), 268-292.
- Vitorello, V. A., Capaldi, F. R., Stefanuto, V. A. (2005). *Recent Advances in Aluminum Toxicity and Resistance in Higher Plants*. *Brazilian Journal of Plant Physiology* 17(1), 129-143.
- Vogel, S. (1994). *Life in Moving Fluids: The Physical Biology of Flow*. Second ed., Princeton University Press, United Kingdom, p. 467.
- Voinov, A. (2008). *Systems Science and Modeling for Ecological Economics*. First ed., Elsevier Academic Press, London, Boston, San Diego, p. 416.
- Watson, C., Pluford, D., Riddell-Black, D. (2003). *Screening of Willow Species for Resistance to Heavy Metals: Comparison of Performance in a Hydroponics System and Field Trials*. *International Journal of Phytoremediation* 5(4), 351-365.
- Wu, J., Hsu, C., Cunningham, S. D. (1999). *Chelate-Assisted Pb Phytoextraction Pb Availability Uptake, and Translocation Constraints*. *Environmental Science Technology* 33(11), 1898-1904.
- Xiaohai, L., Yuntao, G., Khan, S., Gang, D., Aikui, C., Li, L. Y., Lei, Z., Zhonghan, L., Xuecan, W. (2008). *Accumulation of Pb, Cu, and Zn in Native Plants Growing on Contaminated Sites and Their Potential Accumulation Capacity in Heqing, Yunnan*. *Journal of Environmental Science* 20(12), 1469-1474.

- Yang, L. (2008). *Phytoremediation: An Ecotechnology for Treating Contaminated Sites*. Practice Periodical of Hazardous, Toxic, and Radiactive Waste Management 21(4), 290-298.
- Yanqun, Z., Yuan, L., Jianjun, C., Haiyan, C., Li, Q., Schwartz, C. (2005). *Hyperaccumulation of Pb, Zn and Cd in Herbaceous Grown on Lead-Zinc Mining Area in Yunnan, China*. Environment International 31(1), 755-762.
- Yanqun, Z., Yuan, L., Schwartz, C., Langlade, L., Fan, L. (2004). *Accumulation of Pb, Cd, Cu and Zn in Plants and Hyperaccumulator Choice in Lanping Lead-Zinc Mine Area, China*. Environment International 30(1), 567-576.
- Ying, G., Murray, P., Sauvé, S., Hendershot, W. (2002). *Low Metal Bioavailability in Contaminated Urban Site*. Environmental Toxicology and Chemistry 21(5), 954-961.
- Yokel, R. A., McNamara, P. L. (2002). *Aluminum Toxicokinetics: An Updated Minireview*. Pharmacology Toxicology 88(4), 159-167.
- Yoon, J., Cao, X., Zhou, Q., Ma, L. Q. (2006). *Accumulation of Pb, Cu, and Zn in native plants growing on a contaminated Florida site*. Science of the Total Environment 368(1), 456-464.
- Yu, L. J., Shukla, S. S., Dorris, K. L., Shulka, A., Margrave, L. S. (2003). *Adsorption of Chromium from Aqueous Solutions by Maple Sawdust*. Journal of Hazardous Materials B 100(1-3), 53-63.
- Yunusov, B. (2011). *Improving Ecological Parameters of Wastewater by Integrating Various Cleaning Methods*. Chemical and Petroleum Engineering 47(1-2), 133-139.
- Zhao, F. J., Dunham, S. J., McGrath, S. P. (2002). *Arsenic Hyperaccumulation by Different Fern Species*. New Phytologist 156(1), 27-31.
- Zümreoglu-Karan, B., Nedim, A. (2012). *Layered Double Hydroxides-Multifunctional Nanomaterials*. Chemical Papers 66(1), 1-10.