

# Optimizing Total Cost of Ownership (TCO) for 5G Multi-Tenant Mobile BackHaul (MBH) Optical Transport Networks

by

Nassim HADDAJI

MANUSCRIPT-BASED THESIS PRESENTED TO ÉCOLE DE  
TECHNOLOGIE SUPÉRIEURE  
IN PARTIAL FULFILLMENT FOR THE DEGREE OF  
DOCTOR OF PHILOSOPHY  
Ph.D.

MONTREAL, "FEBRUARY 5, 2019"

ÉCOLE DE TECHNOLOGIE SUPÉRIEURE  
UNIVERSITÉ DU QUÉBEC



Nassim HADDAJI, 2019



This Creative Commons license allows readers to download this work and share it with others as long as the author is credited. The content of this work cannot be modified in any way or used commercially.

**BOARD OF EXAMINERS**

THIS THESIS HAS BEEN EVALUATED

BY THE FOLLOWING BOARD OF EXAMINERS

M. Mohamed Cheriet, Thesis Supervisor  
Department of Automated Production Engineering, Ecole de Technologie Supérieure (ETS)  
Montreal, Quebec, Canada H3C 1K3

M. Kim-Khoa Nguyen, Co-supervisor  
Department of Electrical Engineering, Ecole de Technologie Supérieure (ETS)

M. Chamseddine Talhi, President of the Board of Examiners  
Department of Software Engineering and IT, Ecole de Technologie Supérieure (ETS)

M. Michel Kadoch, Member of the jury  
Department of Electrical Engineering, Ecole de Technologie Supérieure (ETS)

M. Roch H. Glitho, External Examiner  
Concordia Institute of Information Systems Engineering - CIISE, Concordia University  
Montreal, Quebec, Canada H3G 2W1

THIS THESIS WAS PRESENTED AND DEFENDED

IN THE PRESENCE OF A BOARD OF EXAMINERS AND THE PUBLIC

ON "JANUARY 18, 2019"

AT ÉCOLE DE TECHNOLOGIE SUPÉRIEURE



## FOREWORD

This dissertation is submitted for the degree of Doctor of Philosophy at the University of Quebec, Ecole de Technologie Superieure (ETS). The research described herein was conducted under the supervision of Professor Mohamed Cheriet in the Department of Automated Production Engineering and Professor Kim-Khoa Nguyen in the Department of Electrical Engineering, between October 2015 and October 2018.

This work is to the best of my knowledge original, except where acknowledgements and references are made to previous work. Neither this, nor any substantially similar dissertation has been or is being submitted for any other degree, diploma or other qualification at any other university.

Part of this work has been presented in the following publications:

1. N. Haddaji, K. Nguyen and M. Cheriet, "Transformative Design Model towards an End-to-end Integrated-Optical-Packet-Network in Metro and Core Networks", IEEE Communications Society, Networks 2016 Conference, September 2016.
2. N. Haddaji, K. Nguyen and M. Cheriet, "Towards End-to-End Integrated Optical Packet Network: Empirical Analysis," Elsevier, Optical Switching and Networking, June 2017. DOI: 10.1016/j.osn.2017.06.003.
3. N. Haddaji, A. Bayati, K. Nguyen, and M. Cheriet, "Backhauling-as-a-Service (BHaaS) for 5G Optical Sliced Networks: An Optimized TCO Approach", IEEE OSA, Journal of Lightwave Technology, July 2018. DOI: 10.1109/JLT.2018.2855148
4. N. Haddaji, K. Nguyen and M. Cheriet, "TCO Planning Game for 5G Multi-Tenant Virtualized Mobile BackHaul (V-MBH) Network", submitted to IEEE OSA, Journal of Lightwave Technology, January 2019.

5. N. Haddaji, K. Nguyen and M. Cheriet, "Optimizing Profit Margins for 5G Multi-Tenant Virtualized Mobile BackHaul (V-MBH) Network", submitted to 15th International Wireless Communications & Mobile Computing Conference, June 2019.

Nassim HADDAJI

January 2019

## ACKNOWLEDGEMENTS

I would like to thank all the people who are continuously supporting me with their valuable encouragements. I would never have been able to continue my work with same energy and motivation without the guidance of my professors and committee members, help from friends, and support from my parents and my family.

I would like to express my deepest gratitude to my supervisor Professor Mohamed CHERIET, for his excellent guidance, endless caring, patience, and providing me with an excellent atmosphere for doing research.

I am extremely grateful to Professor Kim Khoa NGUYEN, who let me experience the research exercise in the field with nice and practical discussions beyond the textbooks, patiently corrected my writing and drove my work path.

I would like to thank "Synchronmedia lab" team members, who as good friends, were always willing to help and give their best suggestions. My work would not have been possible without their helps.

Special thanks to my parents Salem and Fatima, my uncle Saied in Tunisia, my two brothers Wady and Nabil, and my entire family. They were always supporting me and encouraging me with their best wishes.

Last but not least, I would like to extend extra special thanks to my wife Ibtissam and my four kids Salma, AbderRahman, Abdallah and Mariam for their patience and their sacrifices. They were always there cheering me up and stood by me through the good times and bad.

Nassim HADDAJI





# **Optimisation du coût total de possession (TCO) des réseaux de transport optiques multi-clients pour les réseaux mobiles 5G**

Nassim HADDAJI

## **RÉSUMÉ**

Les éléments de réseau existants atteignent leur fin de vie et les réseaux de transport par paquets ne sont pas optimisés de manière efficace. En particulier, l'architecture des cellules à haute densité dans les futurs réseaux 5G sera confrontée à de grands défis techniques et financiers en raison de l'avalanche de trafic et de la croissance massive des périphériques connectés. La constante augmentation de la densité et de la demande de trafic au sein des futurs réseaux hétérogènes 5G (HetNets) entraînera des coûts de déploiement, d'extension et d'exploitation énormes pour les futurs réseaux Mobile BackHaul (MBH). L'objectif de cette thèse est donc de fournir un mécanisme efficace de planification du réseau physique et un outil d'ingénierie des ressources optimisé afin de réduire le coût total de possession (TCO) et d'augmenter les revenus générés. Cela aidera les fournisseurs de services (SP) et les opérateurs de réseaux mobiles (MNO) à améliorer l'évolutivité de leur réseau et à maintenir des marges de profit des projets (PPM) positives.

Pour atteindre cet objectif, notre cadre de travail doit traiter trois problèmes clés, qui sont résumés comme suit: i) comment concevoir et migrer vers un réseau MBH fiable et évolutif à un coût optimal?, ii) comment contrôler le déploiement et l'activation des ressources du réseau dans un tel MBH en fonction de la demande de trafic requise de manière efficace et rentable?, et iii) comment améliorer le partage des ressources dans un tel réseau et maximiser les marges de profit de manière efficace?

Dans le cadre de nos contributions pour résoudre le premier problème évoqué ci-dessus et pour planifier le MBH avec un TCO réduit et une évolutivité améliorée, nous proposons un plan de migration complet vers un réseau de paquets optiques intégrés de bout en bout (E2-IOPN) pour les réseaux de transport optiques. Nous passons en revue divers défis empiriques rencontrés par un véritable fournisseur de services lors de son processus de transformation vers le réseau E2-IOPN, ainsi que la mise en œuvre d'un plan tel-que-construit (as-built) et d'une conception de haut niveau (HLD) pour la migration vers des technologies à coût-par-bit moins élevé telles que GPON, MPLS-TP, OTN et DWDM de prochaine génération. Ensuite, nous proposons une stratégie à plus long terme basée sur les approches SDN et NFV, qui offrira une création de services rapide de bout en bout avec un contrôle de réseau centralisé rentable. Nous définissons des modèles de coûts CapEx et OpEx et conduisons une étude comparative des coûts qui montre les avantages et l'impact financier de l'introduction de nouvelles technologies à base de paquets à faible coût pour acheminer le trafic de services existants et nouveaux.

Pour aborder le deuxième problème, nous introduisons tout d'abord un algorithme basé sur un modèle de géométrie stochastique (Voronoi Tessellation) afin de définir plus précisément les zones MBH dans une zone géographique et de calculer plus précisément les demandes de trafic

requis et l'infrastructure MBH associée. Afin d'optimiser le déploiement et l'activation des ressources du réseau MBH de manière efficace et rentable, nous proposons une nouvelle méthode appelée BackHauling-as-a-Service (BHaaS) pour la planification du réseau et l'analyse du TCO basée sur la demande de trafic requise et une approche consistant à «vous ne payez que pour ce que vous utilisez». En outre, nous améliorons les performances de la méthode BHaaS en introduisant une nouvelle méthode plus sensible au service, appelée Traffic-Profile-as-a-Service (TPaaS), afin de réduire encore les coûts liés aux profils de trafic activés chaque année. Les résultats montrent que BHaaS et TPaaS peuvent augmenter de 22 % le bénéfice du projet par rapport au modèle de TCO traditionnel.

Enfin, nous introduisons de nouveaux modèles de coûts (CapEx et OpEx) pour le MBH virtualisé (V-MBH) multi-locataires du réseau 5G dans le cadre de notre contribution au troisième problème. En fait, afin d'améliorer le partage des ressources et d'optimiser les bénéfices du réseau, nous développons un nouveau modèle d'optimisation basée sur l'approche "Vous payez uniquement pour l'utilisation que vous en faites" appelé Virtual-Backhaul-as-a-Service (VBaaS). VBaaS peut servir d'outil de planification pour optimiser la marge de profit du projet (PPM) tout en tenant compte du TCO et du retour sur investissement (ROI) généré chaque année. Nous formulons un jeu de tarification (MPG) pour les opérateurs de réseau mobile afin d'optimiser le TCO et de calculer la stratégie de tarification Pareto-Equilibrium optimale pour les instances de service aux locataires (TSI) offertes. Ensuite, nous comparons CapEx, OpEx, TCO, ROI et PPM pour un cas d'utilisation spécifique connu dans l'industrie sous le nom de projet CORD en utilisant le MBH traditionnel (T-MBH) et le virtualisé MBH (V-MBH), ainsi que l'utilisation de la stratégie de prix aléatoire versus la stratégie de prix d'équilibre.

Les résultats de notre méthode offrent aux SPs et aux MNOs une estimation plus précise de la demande de trafic, une planification optimisée de l'infrastructure et le déploiement annuel des ressources, ainsi qu'une analyse TCO optimisée (CapEx et OpEx) avec une stratégie de tarification améliorée et une augmentation du ROI généré. Les résultats numériques montrent que la rentabilité du réseau a été multipliée par trois avec les solutions proposées par rapport aux méthodes traditionnelles MBH (T-MBH).

**Mots-clés:** 5G, MBH, E2IOPN, TCO, ROI, PPM, CapEx, OpEx, SDN, NFV, CORD, BHaaS, TPaaS, VBaaS, Traffic Profiles, Multi-location, Virtualisation, Découpage de réseau, Theorie des jeux, Competition des prix.

# **Optimizing Total Cost of Ownership (TCO) for 5G Multi-Tenant Mobile BackHaul (MBH) Optical Transport Networks**

Nassim HADDAJI

## **ABSTRACT**

Legacy network elements are reaching end-of-life and packet-based transport networks are not efficiently optimized. In particular, high density cell architecture in future 5G networks will face big technical and financial challenges due to avalanche of traffic volume and massive growth in connected devices. Raising density and ever-increasing traffic demand within future 5G Heterogeneous Networks (HetNets) will result in huge deployment, expansion and operating costs for upcoming Mobile BackHaul (MBH) networks with flat revenue generation. Thus, the goal of this dissertation is to provide an efficient physical network planning mechanism and an optimized resource engineering tool in order to reduce the Total Cost of Ownership (TCO) and increase the generated revenues. This will help Service Providers (SPs) and Mobile Network Operators (MNOs) to improve their network scalability and maintain positive Project Profit Margins (PPM).

In order to meet this goal, three key issues are required to be addressed in our framework and are summarized as follows: i) how to design and migrate to a scalable and reliable MBH network in an optimal cost?, ii) how to control the deployment and activation of the network resources in such MBH based on required traffic demand in an efficient and cost-effective way?, and iii) how to enhance the resource sharing in such network and maximize the profit margins in an efficient way?

As part of our contributions to address the first issue highlighted above and to plan the MBH with reduced network TCO and improved scalability, we propose a comprehensive migration plan towards an End-to-End Integrated-Optical-Packet-Network (E2-IOPN) for SP optical transport networks. We review various empirical challenges faced by a real SP during the transformation process towards E2-IOPN as well as the implementation of an as-built plan and a high-level design (HLD) for migrating towards lower cost-per-bit GPON, MPLS-TP, OTN and next-generation DWDM technologies. Then, we propose a longer-term strategy based on SDN and NFV approach that will offer rapid end-to-end service provisioning with cost-efficient centralized network control. We define CapEx and OpEx cost models and drive a cost comparative study that shows the benefit and financial impact of introducing new low-cost packet-based technologies to carry traffic from legacy and new services.

To address the second issue, we first introduce an algorithm based on a stochastic geometry model (Voronoi Tessellation) to more precisely define MBH zones within a geographical area and more accurately calculate required traffic demands and related MBH infrastructure. In order to optimize the deployment and activation of the network resources in the MBH in an efficient and cost-effective way, we propose a novel method called BackHauling-as-a-Service (BHaaS) for network planning and Total Cost of Ownership (TCO) analysis based on required

traffic demand and a "You-pay-only-for-what-you-use" approach. Furthermore, we enhance BHaaS performance by introducing a more service-aware method called Traffic-Profile-as-a-Service (TPaaS) to further drive down the costs based on yearly activated traffic profiles. Results show that BHaaS and TPaaS may enhance by 22% the project benefit compared to traditional TCO model.

Finally, we introduce a new cost (CapEx and OpEx) models for 5G multi-tenant Virtualized MBH (V-MBH) as part of our contribution to address the third issue. In fact, in order to enhance the resource sharing and maximize the network profits, we drive a novel pay-as-you-grow and optimization model for the V-MBH called Virtual-Backhaul-as-a-Service (VBaaS). VBaaS can serve as a planning tool to optimize the Project Profit Margin (PPM) while considering the TCO and the yearly generated Return-on-Investment (ROI). We formulate an MNO Pricing Game (MPG) for TCO optimization to calculate the optimal Pareto-Equilibrium pricing strategy for offered Tenant Service Instances (TSI). Then, we compare CapEx, OpEx, TCO, ROI and PPM for a specific use-case known in the industry as CORD project using Traditional MBH (T-MBH) versus Virtualized MBH (V-MBH) as well as using randomized versus Pareto-Equilibrium pricing strategies.

The results of our framework offer SPs and MNOs a more precise estimation of traffic demand, an optimized infrastructure planning and yearly resource deployment as well as an optimized TCO analysis (CapEx and OpEx) with enhanced pricing strategy and generated ROI. Numerical results show more than three times increase in network profitability using our proposed solutions compared with Traditional MBH (T-MBH) methods.

**Keywords:** 5G, MBH, E2IOPN, TCO, ROI, PPM, CapEx, OpEx, SDN, NFV, CORD, BHaaS, TPaaS, VBaaS, Traffic Profiles, Multi-tenancy, Virtualization, Network slicing, Game theory, Price competition

## TABLE OF CONTENTS

	Page
INTRODUCTION .....	1
0.1 Definitions .....	1
0.1.1 5G technology .....	1
0.1.2 5G service requirements .....	2
0.1.3 Heterogeneous Networks (HetNets) .....	3
0.1.4 Mobile Backhaul (MBH) .....	4
0.1.5 CAPEX, OPEX and TCO analysis .....	5
0.2 General context .....	6
0.2.1 Challenges of network modernization .....	7
0.2.2 Challenges in optimized network engineering .....	8
0.2.3 Challenges for innovative planning tools .....	9
0.3 Emerging 5G technology concepts and Motivation .....	9
0.3.1 Virtualization and softwarization in 5G .....	10
0.3.2 Network slicing and multi-tenancy .....	11
0.3.3 Issues and limitations .....	12
0.3.4 Motivation .....	13
0.4 Problem statement and Research questions .....	14
0.4.1 Problem statement .....	14
0.4.2 Research questions and related main issues .....	15
0.4.2.1 Research question RQ1 .....	15
0.4.2.2 Research question RQ2 .....	16
0.4.2.3 Research question RQ3 .....	16
0.5 Objectives and Methodology .....	17
0.5.1 Research hypothesis .....	17
0.5.2 Main objective .....	17
0.5.3 Specific Objectives .....	17
0.5.3.1 Specific objective SO1 .....	17
0.5.3.2 Specific Objective SO2 .....	18
0.5.3.3 Specific Objective SO3 .....	18
0.5.4 General methodology .....	19
0.5.4.1 Methodology M1: TCO modeling in space (Technological transformation and traffic demand estimation) .....	19
0.5.4.2 Methodology M2: TCO modeling in time (Project life-time optimization) .....	20
0.5.4.3 Methodology M3: TCO competition modeling (MNO Pricing Game (MPG)) .....	21
0.6 Outline of the thesis .....	22
LITERATURE REVIEW .....	25

1.1	The state-of-the-art of transport networks .....	25
1.1.1	Access layer .....	25
1.1.2	Metro layer .....	27
1.1.3	Core layer .....	28
1.1.4	Control layer .....	29
1.2	TCO Optimization for 5G Mobile Backhaul Optical Sliced Networks .....	31
1.2.1	5G MBH Solutions: TCO approach .....	31
1.2.2	Multi-tenancy and Network slicing in 5G MBH .....	32
1.3	Optimizing 5G MBH Profitability by Network Virtualization and Game Theory .....	33
1.3.1	Cost reduction methods .....	33
1.3.2	Network Virtualization .....	34
1.3.3	Game Theory .....	35
1.4	Discussion .....	36
CHAPTER 2	TOWARDS END-TO-END INTEGRATED OPTICAL PACKET NETWORK: EMPIRICAL ANALYSIS .....	41
2.1	Abstract .....	41
2.2	Introduction .....	42
2.3	THE STATE-OF-THE-ART OF TRANSPORT NETWORKS .....	46
2.3.1	Access layer .....	47
2.3.2	Metro layer .....	49
2.3.3	Core layer .....	51
2.3.4	Control layer .....	52
2.4	Challenges in migrating towards E2-IOPN .....	53
2.4.1	Migration challenges in access networks .....	54
2.4.1.1	Out-side Plant (OSP) planning and design .....	54
2.4.1.2	Fiber cables monitoring and fault detection .....	55
2.4.1.3	CPE activation and management .....	55
2.4.2	Migration challenges in metro networks .....	57
2.4.2.1	New ePC network requirements .....	58
2.4.2.2	Legacy TDM based networks challenge .....	60
2.4.2.3	Efficient network control challenge .....	60
2.4.3	Migration challenges in the core network .....	61
2.4.3.1	Cost reduction challenge .....	61
2.4.3.2	Efficient traffic forwarding challenge .....	61
2.4.3.3	Inter-working challenge .....	62
2.4.3.4	Resources monetization challenge .....	62
2.4.3.5	Efficient network control challenge .....	63
2.5	SP migration plan towards E2-IOPN .....	63
2.5.1	Towards GPON in access networks .....	63
2.5.1.1	General architecture .....	64
2.5.1.2	Out-Side Plant (OSP) .....	65

2.5.1.3	Auto Configuration Server (ACS) .....	68
2.5.1.4	Optical Fiber Monitoring System (OFMS) .....	70
2.5.2	Towards MPLS-TP in Metro Networks .....	72
2.5.2.1	General architecture .....	72
2.5.2.2	LTE X2 Traffic Engineering .....	74
2.5.2.3	OAM plan .....	75
2.5.2.4	Network resiliency plan .....	76
2.5.2.5	QoS plan .....	78
2.5.2.6	End-to-end service provisioning .....	81
2.5.2.7	SP network synchronization plan .....	83
2.5.3	Towards OTN and EON in Core Networks .....	85
2.5.3.1	Multi-Layer Optimization (MLO) .....	85
2.5.3.2	Resources Optimization .....	86
2.5.3.3	Resilient Control Planes .....	88
2.5.3.4	Inter-domain service provisioning .....	90
2.5.3.5	End-to-end OAMP plan .....	90
2.5.3.6	Agile photonic layer .....	91
2.5.3.7	Resources monetization .....	91
2.6	SP longer-term strategy: SDN/NFV .....	92
2.6.1	Why SDN? .....	92
2.6.2	Benefits of SDN for E2IOPN .....	92
2.6.3	Challenges facing the migration to SDN .....	94
2.6.4	An SDN vision in E2-IOPN .....	94
2.6.5	Future work: a novel TRT-TE framework .....	95
2.7	Cost comparative study .....	96
2.8	Conclusion .....	100
<b>CHAPTER 3 BACKHAULING-AS-A-SERVICE (BHAAS) FOR 5G OPTICAL SLICED NETWORKS: AN OPTIMIZED TCO APPROACH .....</b>		
<b>103</b>		
3.1	Abstract .....	103
3.2	Introduction .....	104
3.3	Related work .....	106
3.3.1	5G MBH Solutions: TCO approach .....	106
3.3.2	Multi-tenancy and Network slicing in 5G MBH .....	108
3.4	Problem statement and system definition .....	109
3.4.1	Proposed Backhauling-as-a-Service (BHaaS) method .....	111
3.4.2	Proposed Traffic-Profile-as-a-Service (TPaaS) method .....	112
3.5	Cost modeling .....	113
3.5.1	Traditional TCO cost model, .....	113
3.5.2	Proposed BHaaS cost model .....	114
3.5.3	Proposed TPaaS cost model .....	118
3.5.4	MBH survey algorithm for stochastic aggregation zones .....	118
3.6	Results and Discussion .....	120



3.6.1	Traffic demand forecasting using MBH survey algorithm .....	120
3.6.2	Comparing TPaaS, BHaaS and Traditional TCO model .....	121
3.6.3	CapEx and OpEx analysis using TPaaS .....	125
3.6.4	TCO and ROI analysis using TPaaS .....	126
3.6.4.1	Ring-based MBH networks .....	127
3.6.4.2	PON-based MBH networks .....	127
3.6.5	Satisfied traffic demand and activated resources .....	127
3.6.6	Calculation Runtime for various traffic demands .....	128
3.7	Conclusion .....	128
3.8	Acknowledgement .....	131
CHAPTER 4	TCO PLANNING GAME FOR 5G MULTI-TENANT VIRTUALIZED MOBILE BACKHAUL (V-MBH) NETWORK .....	133
4.1	Abstract .....	133
4.2	Introduction .....	134
4.3	Related Work .....	137
4.4	System Model .....	141
4.4.1	VBaaS TCO Optimization .....	141
4.4.1.1	Framework definition .....	141
4.4.1.2	Assumptions .....	144
4.4.1.3	Problem Formulation .....	144
4.4.1.4	Control parameters .....	147
4.4.2	MNO Pricing Game (MPG) .....	149
4.4.2.1	Problem statement .....	149
4.4.2.2	Game definition .....	150
4.4.2.3	Mathematical model .....	151
4.5	Validation and results .....	152
4.5.1	Use case definition .....	154
4.5.2	T-MBH vs V-MBH .....	154
4.5.3	Pareto-equilibrium price .....	158
4.6	Conclusion .....	160
4.7	Acknowledgement .....	161
CONCLUSION AND RECOMMENDATIONS .....		163
5.1	General conclusion .....	163
5.2	Major contributions .....	164
5.3	Discussion and future work .....	166
5.4	Articles in peer-reviewed journals and conferences .....	167



## LIST OF TABLES

	Page
Table 1.1	CapEx and OpEx for Hardware (HW) and Software (SW) components in Traditional and Virtualized MBH network..... 35
Table 2.1	SP activated OAM tools in the metro networks ..... 75
Table 2.2	SP QoS Scheme in the metro network ..... 79
Table 2.3	SP Traffic Engineering model in the metro network ..... 83
Table 2.4	CapEx and OpEx Model parameters ..... 97
Table 2.5	Packet and TDM drop interfaces in Model 1 and Model 2 devices..... 98
Table 3.1	Decision Variables ..... 113
Table 3.2	Problem parameters ..... 114
Table 3.3	Average distance between eNodeBs (Kolydakis et al., 2014)..... 119
Table 3.4	Number of Towers per Aggregation areas ..... 121
Table 3.5	Use case values..... 123
Table 4.1	Costs for Hardware and Software components in T-MBH and V-MBH networks ..... 138
Table 4.2	Symbol Notation ..... 145
Table 4.3	Problem parameters ..... 145
Table 4.4	Input parameters..... 153



## LIST OF FIGURES

	Page
Figure 0.1	Mobile BackHaul (MBH) network..... 4
Figure 0.2	CAPEX and OPEX evolution in Time ..... 5
Figure 0.3	5G massive connectivity demand and main challenges ..... 7
Figure 0.4	Shared resources in Multi-tenant and virtualized 5G ..... 12
Figure 0.5	Outline diagram of the thesis ..... 23
Figure 2.1	<i>SP</i> legacy transport networks architecture ..... 47
Figure 2.2	Current DSL based last-mile network ..... 49
Figure 2.3	<i>SP</i> access network transformation towards GPON based FTTH ..... 56
Figure 2.4	Transport Network transformation towards E2IOPN ..... 64
Figure 2.5	Example of <i>SP</i> passive FDT configuration ..... 67
Figure 2.6	Example of Tagging code of FDTs and Customer Buildings ..... 68
Figure 2.7	Example of missing reflection peaks in OFMS system ..... 71
Figure 2.8	MPLS-TP Network transformation design towards E2-IOPN..... 73
Figure 2.9	Offloading <i>SP</i> traffic to agile OTN and CDC DWDM lower layers ..... 87
Figure 2.10	<i>SP</i> SDN vision in E2-IOPN using TRT-TE application..... 93
Figure 2.11	Cost comparative study using different transport technologies ..... 98
Figure 3.1	Crosshaul network architecture (Fronthaul + Backhaul) for future 5G mobile networks.....107
Figure 3.2	MBH resource assignment and mapping diagram .....117
Figure 3.3	Aggregation areas defined by Voronoi Tessellation algorithm (Montreal island use case).....122
Figure 3.4	Estimated traffic demand for various small cell density zones .....123
Figure 3.5	Comparing TPaas, BHaaS and Traditional TCO .....124

Figure 3.6	CapEx and OpEx yearly evolution for PON and Ring-based networks (using TPaaS) .....	126
Figure 3.7	TCO and ROI yearly evolution for PON and Ring-based networks (using TPaaS) .....	128
Figure 3.8	Yearly evolution of new activated rings, Edge Nodes and Satisfied Traffic Demand for Ring-based networks (using TPaaS) .....	129
Figure 3.9	Calculation runtime using CPLEX optimization tool for various traffic demands .....	130
Figure 4.1	Traditional Mobile BackHaul (T-MBH) network .....	136
Figure 4.2	Resource Mapping Tree in virtualized optical backhaul networks .....	143
Figure 4.3	Slicing MNO V-MBH networks to MVNOs .....	150
Figure 4.4	CapEx and OpEx yearly evolution for T-MBH vs V-MBH .....	154
Figure 4.5	TCO and ROI yearly evolution for T-MBH vs V-MBH .....	156
Figure 4.6	PPM yearly evolution for T-MBH vs V-MBH, Renting servers and VNFaaS scenarios .....	157
Figure 4.7	PPM yearly evolution for V-MBH using Randomized pricing versus Equilibrium pricing .....	159
Figure 4.8	Total PPM for T-MBH vs V-MBH using Randomized pricing and Equilibrium pricing .....	160

## LIST OF ALGORITHMS

	Page
Algorithm 2.1    Automatic ONT remote activation.....	69
Algorithm 3.1    MBH Survey Algorithm: Voronoi diagram and MBH area calculation .....	120



## LIST OF ABBREVIATIONS

ACR	Adaptive Clock Recovery
ACS	Auto-Configuration Server
ACL	Access Control List
APS	Automatic Protection Switching
ANSI	American National Standards Institute
ARPU	Average Revenue Per User
ATN	Aggregation Transport Node
BFD	Bidirectional Forward Detection
BHaaS	BackHauling as a Service
BoD	Bandwidth-on-Demand
BSS	Business Support System
BVT	Bandwidth-Variable Transponders
CapEx	CApital EXPenditure
CAR	Committed Access Rate
CD	Connection Demand
CDC	Colorless, Directionless and Contention-less
CGE	Carrier Grade Ethernet
CIR	Committed Interface Rate
CO	Central Office

CoS	Class of Service
CORD	Central Office Re-architected as a Datacenter
CWDM	Coarse Wavelength Division Multiplexing
CPE	Customer Premise Equipment
CVLAN	Customer VLAN ID
DCI	Data Center Inter-connectivity
DCSP	Differentiated services Code Point
DEI-bit	Drop Eligible Indicator bit
DNI	Dual-Node Interconnection
DSLAM	Digital Subscriber Line Access Multiplexer
DWDM	Dense Wavelength Division Multiplexing
ePC	evolved Packet Core
EON	Elastic Optical Network
ETN	Edge Transport Node
ETSI	European Telecommunications Standards Institute
FDT	Fiber Distribution Termination
FTTH	Fiber-To-The-Home
FTTC	Fiber-To-The-Curb
FM	Fault Monitoring
GACH	Generic Associated CHannel



Gbps	Giga Bit Per Second
GNSS	Global Networks Synchronization System
GPON	Gigabit Passive Optical Network
GUI	Graphical User Interface
HDPE	High-Density Polyethylene Pipe
HetNet	Heterogeneous Networks
HSI	High Speed Internet
IQD	Incremental Quantity Discount
IP	Internet Protocol
LACP	Link Aggregation Control Protocol
LAG	Link Aggregation
LSP	Label Switched Path
LTE	Long Term Evolution
MBH	Mobile BackHaul network
MILP	Mixed Linear Integer Program
MIMO	Multi-Input-Multi-Output) antenna
MPLS-TP	MPLS - Transport Profile
MLO	Multi-Layer Optimization
MNO	Mobile Network Operator
MPG	MNO Pricing Game

MPLS	Multi-Protocol Label Switching
MSOH	Multiplexer Section OverHead
MSPP	Multi-Service Provisioning Platform
MVNO	Mobile Virtual Network Operator
NBI	North-Bound Interfaces
NG-SDH	Next-Generation SDH
NFV	Network Functions Virtualization
NMS	Network Management Systems
NNI	Network Node Interface
OAM	Operation, Administration and Maintenance
OD	Outer Diameter
ODU	Optical Data Unit
OFDM	Orthogonal Frequency Division Multiplexing
OFMS	Optical Fiber Monitoring System
OMCI	ONU management and control interface
ONT	Optical Network Termination
OLT	Optical Line Termination
OpEx	Operating Expenditure
OSI	open systems interconnection
OSP	Out-side Plant

OSS	Operation Support System
OTN	Optical Transport Network
PBB-TE	Provider Backbone Bridge / Traffic Engineering
PCE	Path Computation Engine
PCP	Priority Code Point
PDH	Plesiochronous Digital Hierarchy
PHP	Per-Hop Behaviors
PIR	Peak Interface Rate
PM	Performance Monitoring
PPM	Project Profit Margin
PRC	Primary Reference Clock
PTP	Precise Time Protocol
PTP	Priced Traffic Profile
PW	Pseudo-Wire
PWE3	Pseudo-Wire Edge-to-Edge Emulation
QoE	Quality of Experience
QoS	Quality of Service
RAN	Radio Access Network
ROI	Return On Investment
RSA	Routing and Spectrum Assignment

## XXVIII

RSOH	Regenerator Section OverHead
SDH	Synchronous Digital Hierarchy
SDN	Software-Defined Networks
SONET	Synchronous Optical NETwork
SLA	Service Level Agreements
SP	Service Provider
SSM	Synchronization Status Message
SSS	Spectrum Selective Switch
SSU	Synchronization Supply Units
STD	Satisfied Traffic Demand
STM-x	Synchronous Transport Module - Level x
SVLAN	Service VLAN ID
TCO	Total Cost of Ownership
TDD	Total Traffic Demand
TDM	Time Division Multiplexing
TPaaS	Traffic Profile as a Service
TSI	Tenant Service Instance
TSP	Telecom Service Provider
T-MBH	Traditional Mobile BackHaul network
UNI	User Network Interface

VBaaS	Virtual Backhaul as a Service
VC-x	Virtual Container - Level x
VPN	Virtual Private Network
VNF	Virtual Network Function
VRRP	Virtual Router resilient Protocol
VLAN	Virtual Local Area Network
VM	Virtual Machine
V-MBH	Virtualized Mobile BackHaul Network
WFQ	Weighted Fair Queuing
WRR	Weighted Robin Round
WSON	Wavelentgh Switched Optical Network
WSS	Wavelength Selection Switching



## INTRODUCTION

The purpose of this chapter is to present the motivation for the research activities on optimizing the profitability for 5G multi-tenant Mobile BackHaul (MBH) optical networks and to provide a general background about the importance of this topic in the success of future 5G technology.

### 0.1 Definitions

#### 0.1.1 5G technology

The 5G technology coming in the near future refers to the fifth generation of mobile communication networks. It is being standardized by the 5G-PPP Architecture Working Group (until 2020) to be able to satisfy the ever-increasing traffic demand and to serve more users with stringent service requirements (like higher data rates, ultra-low network latencies and low energy consumption). Mobile broadband services, Machine-to-Machine (M2M) communications, and ultra-low latency applications are the main types of service scenarios offered by 5G technology. The cellular network architecture of future 5G network is based on random and ultra-dense small cells for more flexibility and scalability. The 5G technology is bringing several new concepts such as: Software-Defined Network (SDN), Network Function Virtualization (NFV), millimeter wave spectrum, massive Multi-Input Multi Output (MIMO), network ultra-densification, big data and mobile cloud computing, Internet of Things (IoT), Device-to-Device (D2D) connectivity, green communications, and centralized Radio Access Network (C-RAN). Some of these technologies have been studied in current LTE-Advanced networks. Nevertheless, the exponential growth in traffic demand and data rates in 5G is driving to new scalability and financial challenges that need to be further addressed (I. F. Akyildiz, S. Nie, S-C. Lin, M. Chandrasekaran, 2016)

### 0.1.2 5G service requirements

Few years ago, end-user traffic was generated basically by mobile phones which required relatively low data rates and simple service requirements. Today, several types of connected devices and end-user applications such as smart watches, autonomous vehicles, Internet of Things (IoT), Augmented Reality (AR) and tactile Internet are driving to new network and user experience requirements. Coming 5G technology is bringing even more scalability and performance challenges due to the expected explosion in traffic demand and number of connected devices. The various service requirements of future 5G technology are summarized as follows:

- High connectivity: future cellular architecture is driven by a very high-density Heterogeneous Networks (HetNets) with several small cells inside macro cells to accommodate the cell edge end-users.
- Traffic demand and High data rates: Tremendous avalanche of traffic volume (10 000 x more) with 10+ Gbps peak data rates and 100 Mbps cell edge data rates, etc. that will be addressed in 5G networks by new **eMBB (enhanced Mobile Broadband)** which provides greater data-bandwidth.
- High scalability: due to massive growth in connected devices (50 billion devices, i.e. 10 to 100 x more devices). This will be addressed in 5G networks by new **mMTC (massive Machine Type Communications)** which includes NB-IoT (Narrow-band Internet of Things).
- Reduced latency: due to new services requirements and characteristics such as Ultra-Low Latency (ULL) applications with latency  $\leq 1$  ms. This will be addressed in 5G networks by new **URLLC (Ultra Reliable Low Latency Communications)** which will offer full end-to-end latency reduction.



- Low energy: 1000 times less energy consumption per bit.
- **Ultra low cost !!!**

To address these huge throughput demand and ultra-low latency requirements, it is inevitable to redesign the entire network architecture by considering an end-to-end network integration based on scalable, high bandwidth and Ultra-Low latency (ULL) technologies. A recent solution to drop the end-to-end network latency is based on the emerging network edging concept by building several new **edge data centers** to be as close as possible to the end-users of new 5G applications. This emerging edging approach where most of the network intelligence is moving to the edge / access layer will offer last-mile traffic a higher scalability and much lower propagation delays. The latency calculation will be basically depending on the communication delays introduced by the backhaul network since most of traffic does not to go anymore up to the core datacenters (in the core network). This validate once more the importance of the backhaul network to offer future 5G technology the required scalability, throughput and low latency.

### **0.1.3 Heterogeneous Networks (HetNets)**

Heterogeneous Networks (HetNets) are defined by the cellular networks in the Radio Access Network (RAN) that collect the wireless traffic from the mobile end-users and forward it to the core network. HetNets are based on low-power small cells (like micro-cells, femtocells, pico-cells, and relay nodes) within bigger macro-cells in order to improve the coverage and required capacity. Small cells extend the coverage to the end-users, offload data traffic from congested macro-cells and uniformly distribute the available capacity of the network. The HetNets are connected to the core network thanks to the Mobile Backhaul (MBH) network as shown in Fig. 0.1. (A. BenMimoune, F. A. Khasawneh & M. Kadoch, 2015)

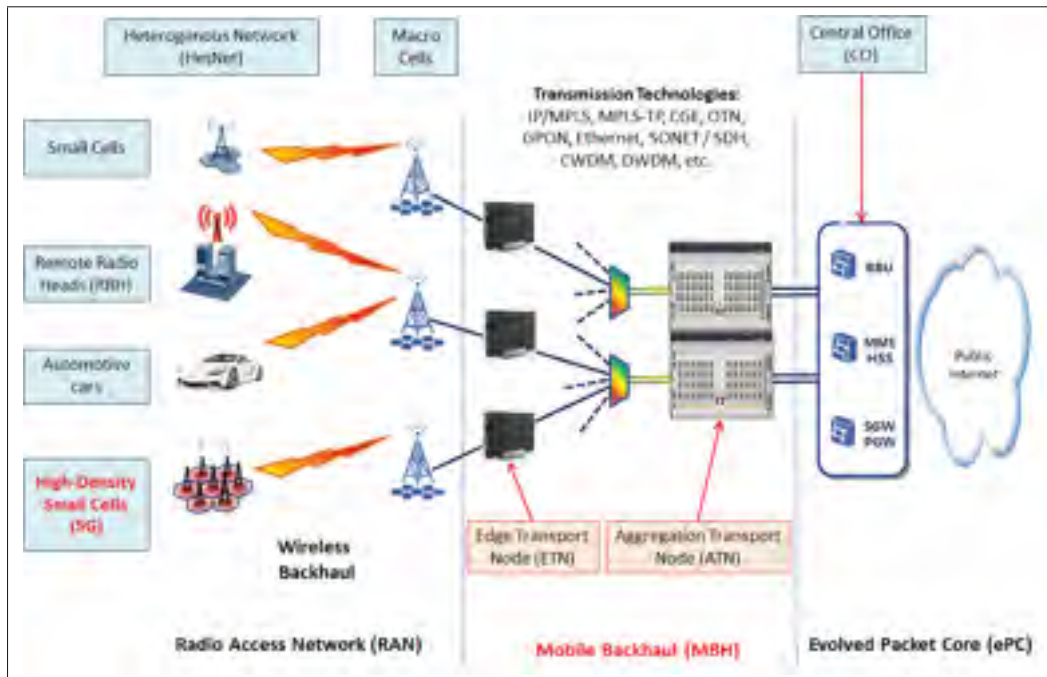

Figure 0.1 Mobile BackHaul (MBH) network

#### 0.1.4 Mobile Backhaul (MBH)

The Mobile Backhaul (MBH) is the access transport network that collects the traffic from several hundreds of high density radio access network (RAN) with hundreds of 3G and 4G mobile towers (respectively, NodeB and eNodeB). MBH then forwards the collected traffic towards centralized BBU (Base Band Unit) pools in the MNO core network. Fig. 0.1 shows the MBH connecting thousands and even millions of current mobile towers (4G eNodeBs) and future 5G Remote Radio Heads (RRH) and MIMO antenna arrays to the Evolved Packet Core (EPC) in the core network. Thus, the MBH has to offer huge end-to-end scalability and reliability to address all end-user service requirements. Different wireless and wireline transport technologies are competing in the MBH such as SONET/SDH, ATM, OTN, GPON, Carrier Grade Ethernet, MPLS-TP, IP/MPLS, etc. (L. Li & S. Shen, 2011)

### 0.1.5 CAPEX, OPEX and TCO analysis

Capital Expenditure (CapEx) is defined as the acquisition and deployment costs required to build or expand a network. Operating Expenditure (OpEx) is defined as the costs required to operate and maintain the deployed and running network. CAPEX and OPEX cost calculation is using published prices from the industry. Fig. 0.2 shows an example of the evolution of the project cost (CAPEX + OPEX) in time and its relationship with generated revenue. The loss point is defined when the costs of any project are higher than the revenue. Nevertheless, the estimation of these costs for mobile networks is challenging and need precise techno-economic modelling. Unlike the availability of CAPEX cost models, precise OPEX models are rare and are often calculated as percentage of the CAPEX costs.



Figure 0.2 CAPEX and OPEX evolution in Time

The Total Cost of Ownership (TCO) analysis is an important step during the planning and design phases of any transport network project that provides a good insight into the impact of each deployment option and strategic decision. The TCO calculation is proportional to the CapEx and OpEx costs over a certain number of years (usually  $Y = 5$ ). It is a main control

and validation tool that offers a good visibility for optimal decision making in terms of how much network resources to be acquired, deployed and operated. In the traditional approach of TCO calculation, the resource requirements are estimated for the entire project at once and thus makes the initial CAPEX very high and challenging for most of the project owners. This may even delay the kick-off time of these projects due to budget limitations. Innovative and comprehensive TCO analysis models and more accurate estimations of CapEx and OpEx are substantial to optimize network TCO and improve the network profitability. While current cost analysis are based on the costs of real hardware devices, the costs of new virtualized network elements need to be considered in the cost models and TCO analysis of coming 5G projects. (T. M. Knoll, 2015)

## **0.2 General context**

Telecommunication networks are facing several scalability and reliability challenges to satisfy the raising number of residential and enterprise customers. The ever-increasing number of mobile end-users with high bandwidth and strict quality of services (QoS) requirements is driving to large network modernization and huge resource expansions in all the layers of the network. In particular, Mobile BackHaul (MBH) networks are growing very fast to be able to connect the massive number of 2G, 3G and 4G mobile towers in the Radio Access Network (RAN) to the mobile core network. 5G Technology is bringing a massive number of mobile towers in the RAN (almost 1 million new outdoor small cell connections in 2019 as shown in Fig. 0.3). This huge number of new small cells drives to huge technical and financial challenges.

In order to address the 5G network requirements, Mobile Network Operators (MNO) are obliged to drive a big end-to-end network transformation that shall cover: i) the last-mile and access layer, ii) the backhaul and aggregation layer, as well as iii) the core and control layers. Particularly, the backhaul represents one of the biggest challenge to the success of coming

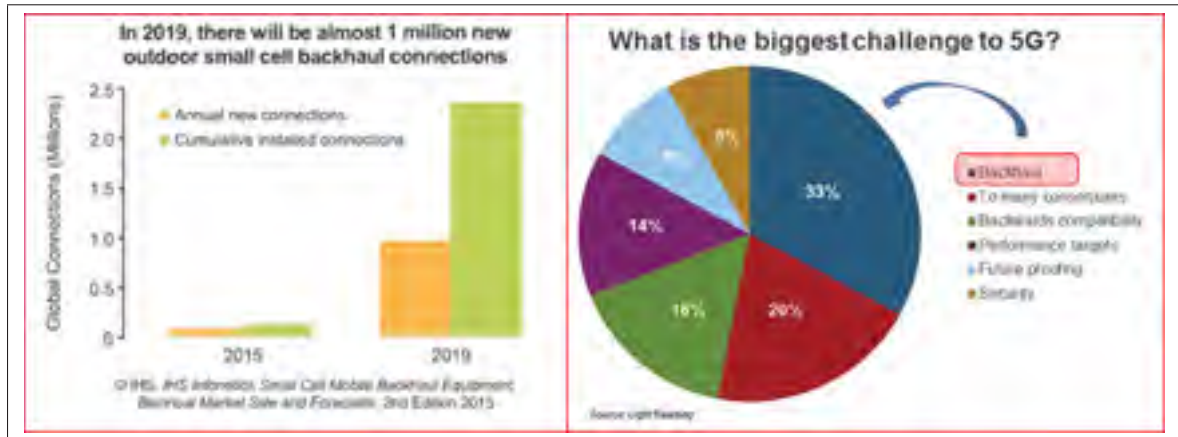

Figure 0.3 5G massive connectivity demand and main challenges

5G technology as shown in Fig. 0.3. The optical transmission technologies remain the most promising solutions for future 5G transport networks. Thus, we focus our work on the optical based mobile backhaul (MBH) of these transport networks. More precisely, we focus on the economics to build and operate future **greenfield** 5G mobile backhaul (MBH) networks where huge budgets are inevitable. The scalability of the 5G network is closely linked to the amount of money that MNOs invest in building, expanding and operating these networks.

### 0.2.1 Challenges of network modernization

Current legacy networks are based on expensive and not anymore efficient devices and technologies. Most of the traffic is unnecessarily crossing expensive and power consuming purpose-built network equipment that are full of unnecessary software stack and complicated upper layer protocols. These traditional networks are becoming overloaded and not anymore profitable and thus, need to be efficiently re-designed. On top of the financial and classical design challenges, MNOs are facing various new technical challenges with the complexity of coming 5G architecture. Legacy Time Division Multiplexing (TDM) technologies are not anymore efficient for current all-IP services. Legacy Digital Subscriber Lines (DSL) solutions using copper cables in the last mile are no longer sufficient to offer the bandwidth and Quality of Services

(QoS) for current quadruple-play services. They have to be replaced by recent FTTH (Fiber-to-the-Home) solutions such as XG-PON (X-Gigabit Passive Optical Network) technologies (Murakami & Koike, 2014). Rigid optical transport technologies such as PDH (Plesiochronous Digital Hierarchy), SDH (Synchronous Digital Hierarchy) and SONET (Synchronous Optical Network) are being replaced by elastic and low-cost all-packets transport networks such as MPLS-TP (Multi Protocol Label Switching-Traffic Profile), OTN (Optical Transport Network) and DWDM (Dense Wavelength Division Multiplexing) technologies (Chun et al., 2014), (Murakami et al., 2014) and (M. Jaber, M. A. Imran, R. Tafazolli & A. Tukmanov, 2016). The huge core traffic; which is currently unnecessarily transiting the IP core transport network; need to be offloaded from the high-cost IP/MPLS routers to the more cost-effective OTN switching networks and DWDM high capacity systems (Hutcheon et al., 2011) and (H. Lee, K. Lee, Na & Y. Lee, 2014). Fig.0.1 shows the mobile transport network and summarizes various transmission technologies competing to connect the RAN to the Evolved Packet Core (EPC) network.

### **0.2.2 Challenges in optimized network engineering**

Network engineering is the exercise of planning the required network infrastructure to carry out a given traffic demand. Several MNOs are over-estimating forecasted traffic demand and thus they are over-designing their network infrastructure. Coming 5G technology is bringing even more traffic demand with exploding number of connected devices. Thus, future 5G networks with high density and heterogenous cell architecture will face huge scalability and profitability challenges. This makes network planning of optical MBH networks a critical and complex problem (Mukhopadhyay & Das, 2015). Excessive procurement and uncontrolled deployment of unused equipment, modules and interfaces is raising the initial MBH deployment costs as well as the later operating costs. Several MNOs are not able to kick-off their MBH projects due to the initial high required budgets (Jaber et al., 2016). Thus, efficient and smart planning is necessary for scalable and profitable MBH project. In order to control the deployment,

expansion and operation costs in more efficient way, innovative planning and design tools are urging for new MBH projects. Network resources need to be monetized and generate new innovative business models. The installation and activation of the network resources in the MBH network need to be controlled and optimized based on required traffic demand in an efficient and cost-effective way.

### **0.2.3 Challenges for innovative planning tools**

Several networks already stopped being profitable due to the high network costs versus the flat generated revenues. Others are still increasing their costs by expanding their MBH network capacities to increase their network scalability. These networks will certainly stop being profitable as well if they continue expanding the network without efficient resource planning and smart pricing strategies. MNOs shall reverse the end-of-profit trend with innovative planning tools, smart services and differentiated prices. They have to start re-thinking how to build and expand their MBH networks in an efficient way to generate higher revenues while keeping the costs as low as possible.

### **0.3 Emerging 5G technology concepts and Motivation**

Traditional MBH (T-MBH) networks are based on expensive hardware with high CapEx and OpEx. These initial high deployment costs need to be invested prior to starting revenue generation. This makes it very hard for several MNOs to kick-off their projects on-time due to lack of budgets. Software Defined Networking (SDN) and Network Function Virtualization (NFV) as well as Network Slicing and Multi-tenancy are emerging concepts in coming 5G technology to maximize resource sharing and reduce the network costs (CAPEX and OPEX).



### 0.3.1 Virtualization and softwarization in 5G

Software-Defined Networks (SDN) (Cho, Lai, Shih & Chao, 2014) and Network Function Virtualization (NFV) (Chen, Rong, Zhang & Kadoch, 2017) are novel concepts that offer openness, flexibility, and efficient resource management. Expensive purpose-built devices in the T-MBH are replaced by low-cost commodity devices (called white-boxes). Although they don't necessarily rely on each other, both virtualization and softwarization have a close relationship and they both benefit and complement each other. In fact, SDN splits the control plane from the data/forwarding plane in the network elements and offer a centralized and holistic network view. This will centrally control the traffic forwarding and enhance the traffic engineering capabilities in order to allow more efficient network resource assignment. NFV moves the network functions (like routing, switching, encryption, firewall, etc) to the cloud and offer them as Virtual Network Functions (VNF). It focuses on network management and optimizes the network VNF services. Most of the network processing and computing intelligence are moved to Virtual Network Functions (VNF) running in centralized servers. These VNFs manage and control the packet forwarding functionalities of the white-boxes to achieve higher scalability and flexibility. In this context, CORD (Central-Office-Re-architected-as-a-Datacenter) (Peterson et al., 2016) is a network virtualization project based on SDN/NFV architecture that offers multi-tenant connectivity (Access-as-a-Service) and elastic cloud services (Software-as-a-Service) for residential (R-CORD), enterprise (E-CORD), and mobile (M-CORD) network applications.

The architecture of coming 5G networks is mainly based on the virtualization (NFV) and softwarization (SDN) concepts to offer creativity, openness and competitiveness to 5G technology. 5G architecture is following this trend by moving most of access, transport and core network related functions to Virtual Machines (VM) running into servers as VNFs and deploy new network services through various network slices. This network virtualization and softwarization



separate the physical infrastructure from its services and thus, simplify the development and deployment of new networking features in a purely software based way. No expensive hardware upgrades as well as installation and configuration of new firmware are required anymore. As a result, this will drastically drop the CapEX and OpEx costs in software based networks. (C. E. Tsirakis & P. Matzoros, 2017)

### **0.3.2 Network slicing and multi-tenancy**

In order to avoid expensive purpose built networks and drop the network costs, the network slicing concept is an emerging solution to maximize resource sharing and network multi-tenancy. In fact, physical mobile network resources like RAN, transport and core networks as well as physical radio resources and licensed spectrum, are abstracted and partitioned into several logical networks or network slices. Each virtual network slice is assigned to a separate service provider or tenant who can access and operate only his part of the whole infrastructure. The remaining parts of the shared network will be totally isolated and transparent to that tenant. In particular, host MNOs lease isolated slices from their Virtualized MBH (V-MBH) to several Mobile Virtual Network Operators (MVNOs) or Tenants. The MVNOs are sharing the resources from the host MNO infrastructure and are competing to serve their own end-users as shown in Fig. 0.4. Thus, each MNO tries to maximize his profit margins by decreasing his TCO and maximizing his Return-on-Investment (ROI) (Sun et al., 2018). Network slicing is connected to the novel concepts of SDN and NFV to correlate and abstract underlying physical resources for each network slice. As a result, differentiated and customized services can be offered to customers by decoupling the network infrastructure from provided services. (D. C. Mur, P. Flegkas, D. Syrivelis, Q. Wei and J. Gutiérrez, 2016). Nevertheless, it is very challenging to MNOs to precisely calculate the costs of their networks while considering the shared network resources.



Figure 0.4 Shared resources in Multi-tenant and virtualized 5G

### 0.3.3 Issues and limitations

Planning scalable 5G MBH transport networks becomes one of the most hard and challenging issues. The migration from massively deployed legacy networks to recent all-IP based solutions is promising but very challenging. There is no efficient mechanism to optimize the deployment and assignment of network resources on yearly basis based on required traffic demand and generated service revenues. Heavy routing protocols in the core network are very expensive and are consuming valuable power and space. Consequently, transport networks are costly and not fully exploited. This results in waste of capacity and affect the network scalability and profitability. Yet, existing planning solutions are no longer appropriate for coming 5G requirements. With a target to reduce the TCO and improve the scalability and profitability of optical MBH networks, prior work focused on the choice of the most efficient and cost-effective technologies as well as the optimization of the number of planned network elements and related costs.

On the other hand, multi-tenancy and network slicing based on virtualized resources are promising solutions to satisfy MBH network greediness while reducing related expenditures. Lower

layer networks (in OSI model) have always been considered as dumb and transparent transport pipes without being monetized. Existing TCO analysis are not fairly considering Service Level Agreements (SLA) between MNOs and their customers. Cost calculation models in prior work are driven by initial estimated hardware quantity and prices. Costs of basic equipment and related modules (subrack, management and power modules, switching fabric, user interfaces, etc) are all considered in the initial cost calculation even before they actually carry traffic and generate revenue. Their TCO models do not scale with the growth of service and generated ROI (Return On Investment). There is no appropriate model that fairly distributes costs over multiple virtual operators, and also optimizes physical resource planning. Cost models do not consider the Average Revenue Per User (ARPU) values generated by satisfying each connected Tenant Service Instances (TSI) and the total ROI generated by yearly activated network services. Continuous expansion of MBH physical networks based on current cost models will drastically increase network TCO for future very high density 5G networks. This represents a very high risk on the profitability and success of future 5G technology.

#### **0.3.4 Motivation**

In order to meet the emerging requirements of future 5G high-density and random cellular architecture, there is an urgent need to efficiently build and operate future Greenfield 5G Mobile Backhaul networks (MBH) with minimum costs and higher scalability. **Innovative planning tools** based on dynamic activation, pay-as-you-grow pricing and yearly distribution of traffic demand need to be developed to avoid over-provisioning infrastructure and precisely calculate the network costs while considering the shared resources. This will help split project costs over several years and avoid high kick-off project budgets. Moreover, costs of various service-aware traffic profiles have to be taken into account according to different end-user Service Level Agreements (SLA) and generated revenues. The Project Profit Margin (defined as  $PPM = ROI - TCO$ ) need to be optimized based on the estimated traffic demands, the time and quantity

of yearly activated MBH resources as well as the generated ROI. The different types and costs of activated traffic profiles as well as virtualization of network resources need to be considered in the PPM optimization models. The wholesale prices are the prices defined by MNOs to lease network slices or connectivity links within the MBH in a higher amount than invested costs in order to generate high Return-on-Investment (ROI) and positive project profit margins (PPM). These wholesale price needs to be further optimized using appropriate game theory models. As a summary, the scalability and profitability of coming 5G MBH network can be achieved by:

- defining the most efficient end-to-end plan for the future transport networks based on the most scalable and cost-effective transmission technologies
- efficiently controlling the deployment and activation of network resources and optimizing the long-term TCO.
- using recent network slicing and virtualisation concepts to maximize the resource sharing and enhancing the Project Profit Margins (PPM).

## **0.4 Problem statement and Research questions**

### **0.4.1 Problem statement**

The research problem addressed in our work is stated as follows:

How to precisely estimate future 5G MBH Total Cost of Ownership (TCO) while considering shared resources and new 5G network architecture and related emerging technologies?

## 0.4.2 Research questions and related main issues

In order to address above problem statement and drive our work methodology that will be discussed in Section 0.5, we further detail the problem statement into four research questions (RQ) as follows:

### 0.4.2.1 Research question RQ1

**RQ1:** Planning and optimizing the Total Traffic Demand (TTD) and required network infrastructure within greenfield 5G backhauling zones in a cost-effective way?

The main issues related to RQ1 are:

- How to optimize network planning by focusing on the contributions and the impact of the IEEE, ITU, and IETF standards in the lower layers of the telecommunications stack such as GPON (Gigabit Passive Optical Network), Wavelength Division Multiplexing (WDM), Carrier Grade Ethernet (CGE), Optical Transport Network (OTN), Multi-Protocol Label Switching (MPLS) and MPLS-Traffic Profile (MPLS-TP)?
- How to address technical challenges that most MNOs are facing to build their migration plan toward the E2-IOPN and how to compensate the lack of detailed standardization?
- How to accurately estimate the MBH network deployment and operating costs in order to precisely evaluate and validate the investments in building the network infrastructure?
- How to reduce the infrastructure costs and monetize the network resources in order for MNOs to generate new revenue streams and maintain positive PPM?

#### **0.4.2.2 Research question RQ2**

**RQ2:** Modeling and optimizing the deployment and activation time of greenfield 5G MBH network resources while minimizing the costs and increasing the generated revenues?

The main issues related to RQ2 are:

- How to optimize the deployment and activation of the network hardware and software resources in the backhaul network in an efficient and cost-effective way?
- How to accurately estimate the network costs for software based Virtualized backhaul (V-MBH) networks?
- How to implement accurate decision-helping tools to optimize the resource distribution and activation time over the project lifetime based on given traffic demand and generated ROI?

#### **0.4.2.3 Research question RQ3**

**RQ3:** Modeling the price competition of multiple host Mobile Network Operators (MNOs) and calculating the Nash equilibrium in the 5G oligopoly market?

The main issues related to RQ3 are:

- How to fairly distribute costs and optimize physical resource sharing over multiple MVNOs?
- How to reduce the network TCO and maintain positive PPM for software based V-MBH while considering competing MNO strategies?
- How to define the optimal pricing strategy for offered V-MBH slices to various MVNOs?
- How to implement accurate decision-helping tools to optimize the resource distribution and activation time over the project lifetime based on Pareto-Equilibrium pricing strategy?

## **0.5 Objectives and Methodology**

### **0.5.1 Research hypothesis**

The research hypothesis (RH) of this framework is defined as follows:

**RH:** By optimizing a dynamic distribution and activation over the **space** and over the **time** of the network shared resources and by defining a Pareto-Equilibrium **pricing strategy**, we reduce the Total Cost of Ownership (TCO) of the 5G Multi-Tenant and Virtualized Mobile BackHaul (MBH) and improve the 5G network profit and scalability.

### **0.5.2 Main objective**

The main objective (MO) of this framework is defined as follows:

**MO:** Modeling and optimizing the Total Cost of Ownership (TCO) of 5G MBH network by optimizing the distribution of MBH resources over the **space** and over the **time** and by determining the **Nash equilibrium** that optimize the revenue of all competitors.

### **0.5.3 Specific Objectives**

The main objective (MO) can be further detailed into three specific objectives SO-1, SO-2 and SO-3 that respectively address above research questions RQ-1, RQ-2 and RQ-3:

#### **0.5.3.1 Specific objective SO1**

The first specific objective (SO) of this framework is defined as follows:

**SO-1:** Optimizing the distribution over the **space** of MBH backhauling zones and calculating the Total Traffic demand (TTD) in each zone.

In order to drop the high costs and increase the scalability and profitability of today overloaded networks, we need to efficiently plan future transport networks and optimize deployed resources while generating new revenues accordingly. Thus, our objective is to optimize the distribution of Backhauling Zones (using Voronoi tessellation) and estimate Total Traffic Demand (TTD) in each zone. Then, we build an efficient migration plan towards an End-to-End Integrated-Optical-Packet-Network (E2-IOPN) in access, metro and core networks. We review various empirical challenges during the transformation project towards E2-IOPN and we propose an implementation plan and high-level design for migrating towards GPON, MPLS-TP, OTN and next-generation DWDM.

### **0.5.3.2 Specific Objective SO2**

**SO-2:** Optimizing the evolution of network TCO and ROI over the **time**

Many MNOs are still over-designing their network infrastructure due to their initial over-estimation of traffic demand. With the ever-increasing traffic demand and fast growth in connected devices, future 5G networks with high density cell architecture will face huge scalability and profitability challenges. Huge deployment, expansion and operating costs are expected for upcoming 5G high density MBH networks. Recent SDN, NFV, multi-tenancy and network slicing concepts are emerging solutions to maximize resource sharing and network profits. We need to anticipate novel and efficient planning techniques to optimize the deployment and activation of the network resources in the backhaul network based on required traffic demand.

### **0.5.3.3 Specific Objective SO3**

**SO-3:** Modeling the pricing competition among tenants and determine the equilibrium that optimize the revenue of all competitors.



Given the MBH network which is virtualized, sliced and is exploited by a set of MNOs. Network resources of these host MNOs are sliced and leased to several Mobile Virtual Network Operators (MVNO) or Tenants who are renting V-MBH slices at a wholesale price to connect their towers. We define and model the pricing game taking into account the best strategies of the various competing MNOs in an oligopoly 5G market. Then, we calculate the Nash-equilibrium (best schedule) to activate their network resources in order to maximize their revenues.

#### **0.5.4 General methodology**

We propose three consecutive methodologies M1, M2 and M3 to respectively address the requirements of the research questions RQ1, RQ2 and RQ3 (discussed in Section 0.4.2) as well as the specific objective SO1, SO2 and SO3 (discussed in Section 0.5). The three methodologies are defined as follows:

##### **0.5.4.1 Methodology M1: TCO modeling in space (Technological transformation and traffic demand estimation)**

The methodology M1 addresses the research question RQ1 and the specific objective SO1. In this methodology, we present a practical transformation experience for a real service provider towards an *End-to-End Integrated Optical Packet Network (E2-IOPN)* as a first necessary step for next generation reliable and low-cost MBH networks. This transformation project was implemented in this network following a long literature review and market analysis with various technology partners and solution vendors in the telecoms industry. The methodology M1 is summarized as follows:

- Introduce a novel algorithm based on stochastic geometry algorithm (Voronoi Tessellation) to more precisely define the backhauling zones within a geographical area and optimize their estimated Total Traffic Demand (TTD) in each zone for more accurate TCO analysis.

- Conduct a detailed empirical analysis of the various challenges and issues faced by a real service provider *SP* in his network modernization towards a more advanced and cost-effective E2IOPN network.
- Define a comprehensive high-level design (HLD) as implemented by that service provider *SP* that considers the integration (hand-shake) and inter-operability solutions between the various technologies used within E2IOPN layers.
- Assure a detailed CapEx and OpEx comparative study between the different optical technologies that may be used within the E2IOPN.

#### **0.5.4.2 Methodology M2: TCO modeling in time (Project life-time optimization)**

The methodology M2 addresses the research question RQ2 and the specific objective SO2. In this methodology, we define new models for the CapEx and OpEx costs for the Traditional MBH (T-MBH) network based on purpose-built hardware devices. We propose a new planning method to optimize the deployment and control the utilization of future T-MBH resources. We propose a novel TCO analysis method that can be implemented as a decision-helping and network planning tool to optimize the distribution and activation time of the T-MBH resources over the project lifetime. The methodology M2 is summarized as follows:

1. Define a comprehensive CapEX and OpEX calculation model for optical T-MBH networks.
2. Propose a novel TCO analysis method called BackHauling-as-a-Service (BHaaS) based on "You-pay-only-for-what-you-use" to optimize the yearly planned deployment and activation of resources based on a given traffic demand and related generated revenues.

3. Enhance the previous BackHauling-as-a-Service (BHaaS) method by a more service-aware method called Traffic-Profile-as-a-Service (TPaaS) that further optimizes the TCO by considering the various costs of different traffic profiles.
4. We propose a detailed CapEX and OpEx cost formulation for SDN/NFV based 5G multi-tenant V-MBH in order to reduce network costs and dynamically scale the network infrastructure following the ever-increasing traffic demand.
5. We introduce a novel pay-as-you-grow and service-aware optimization model called Virtual-Backhaul-as-a-Service (VBaaS) as a planning tool for future V-MBH projects to optimize the PPM and the yearly deployment and activation of software and hardware components.

#### **0.5.4.3 Methodology M3: TCO competition modeling (MNO Pricing Game (MPG))**

The methodology M3 addresses the research question RQ3 and the specific objective SO3. In this methodology, we extend the TPaaS cost model discussed in M2 and used for T-MBH networks to software-based multi-tenant Virtualized MBH (V-MBH) networks by introducing a novel pay-as-you-grow and optimization model called Virtual-Backhaul-as-a-Service (VBaaS). VBaaS is a planning tool to optimize the Project Profit Margin (PPM) while minimizing the TCO and maximizing the yearly generated ROI. We also formulate an MNO Pricing Game (MPG) for TCO optimization to calculate the optimal Pareto-Equilibrium pricing strategy for offered software based connectivity services called Tenant Service Instances (TSI). The methodology M3 is summarized as follows:

1. We define a price competition game to model the interaction between resource activation and price strategies of multiple competing MNOs in order to calculate the optimal Pareto-Equilibrium prices for offered backhauling services.

## 0.6 Outline of the thesis

This current "Introduction" (Chapter 0) presents the general context, the problem statement and the objectives of this research framework. It also defines the proposed methodology to address the various research questions of the problem. A summary outline diagram of the thesis is presented in Fig. 0.5. Chapter 1 reviews the prior work related to the scope of the research problems. The three next chapters present the three articles published in response to the specific research questions. The three articles are outlined as follows:

1. Chapter 2: Towards End-to-End Integrated Optical Packet Network: Empirical Analysis
2. Chapter 3: Backhauling-as-a-Service (BHaaS) for 5G Optical Sliced Networks: An Optimized TCO Approach.
3. Chapter 4: TCO Planning Game for 5G Multi-Tenant Virtualized Mobile BackHaul (V-MBH) Network.

Chapter 5 presents a general conclusion of the thesis and a global discussion about this work and future horizons.

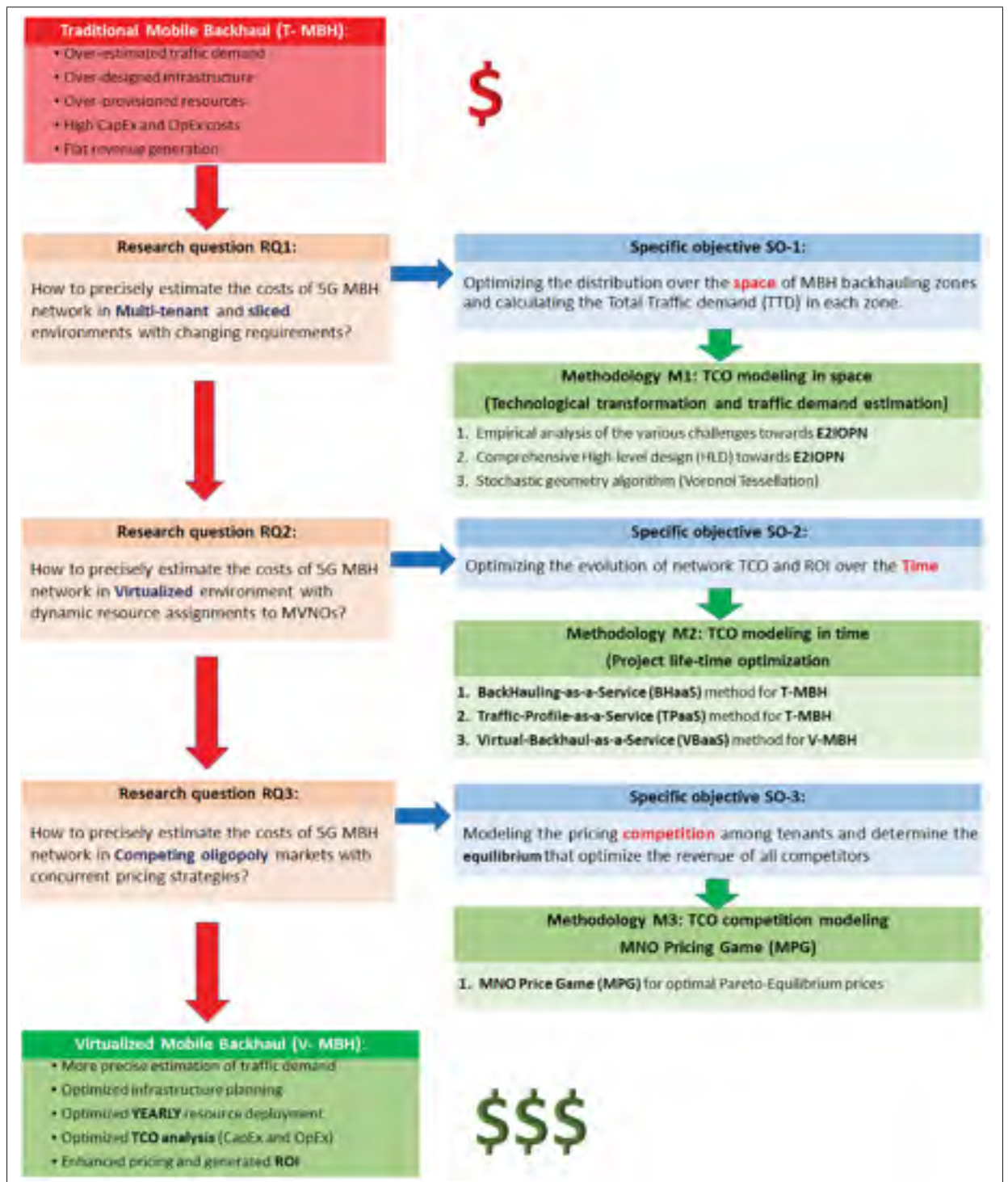

Figure 0.5 Outline diagram of the thesis



## **LITERATURE REVIEW**

This chapter presents a review of the state-of-the-art methods related to the TCO optimization problem for 5G Mobile Backhaul (MBH) Optical Networks. This chapter is divided into Three (3) sections that are in line with the challenges discussed in the introduction and faced by Mobile Network Operators (MNOs) to build and operate future high density 5G networks. The first section presents the various technical and financial challenges encountered by MNOs in the different layers of the network. The second section presents several cost modeling and TCO analysis as well as network slicing and multi-tenancy methods to increase the resource sharing and reduce the raising costs. The third section covers the emerging solutions to increase the network profitability based on network virtualization and software defined networks. It covers also several price competition gaming models to define and correlate pricing best response strategies.

### **1.1 The state-of-the-art of transport networks**

The E2-IOPN is addressing end-to-end service provisioning and quality monitoring across all layers of the transport networks (Polito et al., 2011). The discussion is addressing all parts of the network starting from access and metro backhaul networks to core transport networks. In fact, DSL lines were widely deployed in the access to connect the different services end-users in the last-mile layer. Stacked SDH rings used to be the main transport technology in the backhaul and metro networks to forward the traffic from the access aggregation components to the core. The core network is based on IP/MPLS core routers connected together in a mesh by higher granularity SDH containers over DWDM wavelengths or directly by DWDM links (IPoDWDM). Each layer and each technology of the legacy network used to be managed and controlled by separate Management Systems from different vendors.

#### **1.1.1 Access layer**

Most of the service providers are still using already massively-deployed copper-based technologies (e.g. ADSL2+ and VDSL2) for residential Triple / Quadruple play customers as well

as Ethernet-based leased lines for small enterprise and business customers. The last-mile network within the access layer provides interfaces of several Mbps to these end-users. These customers are usually connected to an aggregation equipment (called DSLAM for Digital Subscriber Line Access Multiplexer) in a star (hub-and-spoke) topology. DSL customers can be connected directly to the DSLAM located in the Central Offices (CO) if they are close or to smaller mini-DSLAMs located inside Active Street Cabinets to increase the reach (in case of longer distances). Aggregated traffic is forwarded by the DSLAM to the IP based core network.

In the mobile backhaul network, the traffic pattern in 2G/GSM BTS, 3G/UMTS NodeB and 4G/LTE eNodeB is in general also forming a star topology with the core network (Base Station Controller BSC, Radio Network Controller RNC and enhanced Packet Core ePC). Most of Mobile Network Operators (MNO) are still using already massively-deployed TDM-based SDH technology to collect traffic coming from Radio Access Networks (RAN). However, FTTH technologies (e.g. GPON, NG-PON and WDM-PON) are emerging and offering low cost-per-bit solutions and almost unlimited bandwidth. While NG-PON and WDM-PON standards are still lacking maturity, FTTH networks based on GPON technology are achieving a lot of success for residential and small business customers. The number of deployed GPON networks is increasing exponentially (Maes et al., 2012), (Murakami et al., 2014) et (Effenberger, et al., 2007). They have been used by several MNOs as the main mobile backhaul solution regardless of their limited scalability and reliability (Verbrugge et al., 2008).

Moreover, MPLS-TP technology was recently introduced as more suitable solution, replacing SDH and SONET in both access and metro networks. In particular, MPLS-TP is becoming the promising solution regarding backhauling 2G, 3G and 4G traffic (Bitar, 2011) and (Sommer, et al., 2010). Service providers (in particular, MNOs) are gradually phasing out their SDH/SONET networks and migrating to MPLS-TP technology. Nevertheless, some enterprise customers (education, government, industrial and financial sectors) with delay-sensitive applications and no tolerance to shared network resources (like in GPON and MPLS-TP), strongly require higher capacity (up to 10 Gbps) and dedicated low-latency connectivity. In these particular cases, direct point-to-point Active Ethernet (ptp-AE) link is commonly offered as al-



ternative low-cost solution. Service providers may also adopt a wavelength-to-an-enterprise vision or a “spectral slice to a user” as a more efficient but more expensive solution (Kachris et al., 2012) and (Gumaste et al., 2013).

### **1.1.2 Metro layer**

The metro layer connects different sites inside metropolitan areas with speeds up to 100 Gbps are required. Depending on the size of the metropolitan networks, service providers are usually splitting the metro layer to metro access, metro aggregation (or edge) and metro core. The sites can be different Point-of-Presence (POP) or COs belonging to the same service provider. All traffic coming from the access layer is aggregated in the POP and forwarded to the core network (Rambach, et al., 2013). The sites can also be different offices belonging to the same enterprise connected through an L2 or L3 VPNs. Although most of the service providers are migrating this layer to pure Ethernet-based packet technologies, several metro networks are still based on legacy SDH and more recent MSPP (NG-SDH). In MSPP, Ethernet traffic is mapped over SDH virtual containers using GFP (Generic Framing Procedure) adaptation protocol (Gumaste et al., 2013) and (Huang et al., 2008). Until very recently, SDH and its flavors were the dominating transmission networks thanks to their strong OAM tools. These tools offers high efficiency for TDM voice as well as high QoS and security for low-rate data traffic (Sommer, et al., 2010).

SDH technology is phasing out due to its rigid TDM-based pipes (Chun et al., 2014). There are emerging Carrier-Grade Ethernet (CGE) technologies to replace SDH in the metro access and metro aggregation layer, like PBB-TE (Provider Backbone Bridge / Traffic Engineering G802.1ah) (Gumaste et al., 2013) or MPLS-TP in which MPLS-TP would be the promizing one (Cao et al., 2010), (Sommer, et al., 2010) and (Murakami et al., 2014). As in the access networks, MPLS-TP, which can be defined in a simplest way as the Transport Profile of IP/MPLS, is gradually replacing SDH (Choi, 2016). It is an Ethernet-based low cost solution that offers required performance, scalability, and especially CapEx (CAPital EXpenditure) and OpEx (OPeration EXpenditure) reduction (Rambach, et al., 2013). It offers multi-service adaptation and high bandwidth utilization thanks to statistical multiplexing. It also provides simple

and user-friendly plug-and-click provisioning using Graphical User Interface (GUI) portals. MPLS-TP provides strong SDH-like resiliency mechanisms (less than 50 ms, 1:1 LSP protection, PW APS...) as well as pro-active carrier class OAM tools with strong QoS schemes. It offers also PTP IEEE 1588 Precise Timing Protocol for LTE network synchronization (Huang et al., 2009) and (Golnari, Shabany, Nezamalhoseini & Gulak, 2015).

Recently, OTN switching is also gaining a lot of attention in metro networks (Donovan et al., 2008) and (H. Lee, K. Lee, Na & Y. Lee, 2014). Thanks to its robust multi-service transport infrastructure scaling from 1 Gbps up to 100 Gbps, OTN is now recognized as the next generation switched transport solution for multi-service packet optical networks in the core, metro core and even metro aggregation layers. Furthermore, few service providers have even started deploying OTN down to the access network for business customers' use cases where no statistical multiplexing is required and where bandwidth granularity is starting from 1 Gbps and beyond.

### **1.1.3 Core layer**

In the core network, services are often routed by IP/MPLS Provider routers (known as P routers). Traffic coming from the metro networks is first received by Provider Edge (PE) routers that map pure IP traffic into MPLS tunnels. A number of 40 Gbps and 100 Gbps optical interfaces are connecting the IP core routers in mesh topology or in multiple connected rings on top of the huge long haul and ultra-long haul DWDM transmission bandwidth (Roy, Turkcu, Hand & Melle, 2014). To increase reliability, service providers often use mesh topology to have more efficient protection and restoration mechanisms. IP/MPLS network offers good control but relatively high cost per port, which limits growing networks scalability (Rambach et al., 2013). Also, delay-sensitive applications are strongly affected by the huge latency introduced by the heavy routing processes. Statistics show that more than 70% of the traffic remains inside the metro network or does not need to go to IP core layer thanks to its deterministic traffic pattern. This traffic is mainly connection-oriented and is unnecessarily crossing the IP/MPLS network. It should be offloaded to lower layers (Cao et al., 2010).

Thanks to its robust multi-service transport infrastructure scaling from 1 Gbps up to 100 Gbps per wavelength, several service providers are gradually introducing OTN in their core networks by offloading deterministic traffic to lower layers using ODU switching on top of 40 Gbps and 100 Gbps DWDM links. Service providers have to maximize the value of each technology in the network and enable traffic transport at the most cost-effective layer (Yin et al., 2012). MPLS-TP traffic coming from access and metro access networks is also groomed in ODU-x ( $x=1..4$ ) switched tunnels. On the photonic layer, 40 Gbps and 100 Gbps DWDM wavelength channels are currently carrying OTN groomed ODUs (Donovan et al., 2008) and (Lee et al., 2014).

As one of the most promising solutions for next-generation optical networks, Elastic Optical Networking (EON) offers dynamic and on-demand spectrum resource assignment to next-generation core networks. Using Bandwidth-Variable Transponders (BVT) and Spectrum Selective Switches (SSS), connection services are mapped into dedicated slots within standardized flexible spectral grid (from 6.25 and 12.5 GHz sub-wavelength up to 400 GHz superchannels and beyond). Lightpath is transmitted over single-carrier or coherent Optical Orthogonal Frequency Division Multiplexing (CO-OFDM) transmission schemes. Recently, legacy GMPLS based Routing and Spectrum Assignment (RSA) mechanisms are migrating to more flexible and programmable GMPLS/PCE and SDN based control planes. Service provisioning calculation in core networks is moving to centralized Path Computation Element (PCE) in the Software Defined EON (SD-EON) architecture (Liu et al., 2014), (Iovanna, Ubaldi & Di Michele, 2014) and (Chen et al., 2016).

#### **1.1.4 Control layer**

Currently, the network control layer is based on i) separate Network Management Systems (NMS) to control and manage each network domain and ii) several control plane protocols embedded within the devices themselves to communicate among each other. Most of the time, each vendor NMS is using proprietary interfaces and protocols to communicate with the same vendor network devices. In several cases, this vendor is having separate NMS for each kind of

technology. The network control layer is becoming very complicated with different network islands managed by different NMS systems. This is causing a number of inter-operability and inter-domain service provisioning issues (Chamania et al., 2009). For more flexibility and efficiency, operators are migrating to SDN/NFV based unified and centralized network control. SDN architecture is based on decoupling the control plane of network elements from the hardware, and implementing it in upper software-based layers. Only data plane (forwarding plane) remains in the network devices. This architecture efficiently reduces complexity and cost of the network infrastructure and thus, solves the increasing network scalability issue. NFV concept is based on virtualizing several network functions (routing, firewall, encryption, etc) and shifting the network intelligence to cloud-based building blocks, called Virtual Network Functions (VNFs) (Thyagaturu et al., 2016). Totally offloaded from legacy dedicated hardware, these VNFs reside in one or more virtual machines in IT virtualized environments (Thyagaturu et al., 2016), (Liu, 2014), (Li & Chen, 2015) and (Cyan Inc, 2014). More details about SDN architecture and its features are discussed in Section 5.

In particular, new control plane designs are emerging to offer more flexibility and programmability to SD-EONs. (Liu et al., 2014) investigate the performance and validate the feasibility of EON architecture based on low-cost Direct-Detection Optical OFDM (DDO-OFDM) scheme in core networks under OpenFlow-based SDN control plane. (Zhu et al., 2015) introduce a novel inter-domain protocol (IDP) design and a multi-domain cooperative RSA algorithm for SD-EON multi-domain use cases. (Giorgetti, Paolucci, Cugini & Castoldi, 2015) propose a novel Hierarchical PCE (HPCE) architecture that uses BGP-LS (Border Gateway Protocol - Link State extension) to pro-actively update the parent PCE (pPCE) and offer end-to-end inter-domain service provisioning. Intra-domain path calculation remains under the custody of local child PCEs (cPCE). (Chen et al., 2016) discuss the role of competing brokers in OpenFlow based SD-EON cross-domain service orchestration. An effective revenue-driven bidding strategy is proposed to optimize service pricing and increase brokers' profit based on competition behaviors prediction.

## 1.2 TCO Optimization for 5G Mobile Backhaul Optical Sliced Networks

### 1.2.1 5G MBH Solutions: TCO approach

Several technologies and techniques are proposed in the literature to plan efficient 5G MBH with reduced long-term TCO (Khan, Kellerer, Kozu & Yabusaki, 2011). (La Oliva et al., 2015) and (Mur, Flegkas, Syrivelis, Wei & Gutiérrez, 2016) emphasize on the novel concept of Crosshaul (Xhaul) as a cost-effective architecture. Xhaul architecture is defined by integrating 5G backhaul and fronthaul transport networks for flexible and heterogeneous transmission links. Different network architecture (tree, ring, etc) are integrated in a unified Xhaul packet Forwarding Element (XFE) and controlled by a central processing unit to reduce CapEx and OpEx. (Kolydakis & Tomkos, 2014) proposes a TCO comparison between wireless and fiber technologies in 5G fronthaul and backhaul solutions which shows that fiber is more cost effective than wireless in high density areas (less than 1 km spacing distance between adjacent eNodeBs).

From evolving fiber solutions perspective, (Ranaweera et al., 2013) discusses advantages of PON technology in reducing up to 60% of 5G MBH cost. Traffic is collected by Edge Transport Nodes (ETN) and forwarded to Aggregation Transport Nodes (ATN) using the optimized fiber routes, locations of splitters, and number of ports. (Sung, Chow, Yeh & Chang, 2015) adopts spectral-efficient OFDM (Orthogonal Frequency Division Multiplexing) modulation technique and proposes an Optical Distribution Network (ODN) sharing scheme based on existing PON infrastructure to avoid deploying new fiber cables. (H. Chen et al., 2016) applies K-means clustering and a multi-stage access nodes strategy with shared cable ducts and introduces a cost-effective solution based on TWDM-PON (Time and Wavelength Division Multiplexed PON) to optimize cost of dense 5G MBH. These solutions assume all OLTs covering the whole geographical area are co-located in a single Central Office (CO). Several cost modeling and optimization methods have been presented for optical network TCO analysis. (Jarray, Jaumard & Houle, 2010) proposes CapEx and OpEx cost modeling and a MILP (Mixed Integer Linear Programming) optimization method for large scale mesh networks based on column

generation techniques and a rounding off heuristic. (Mahloo, Monti, Chen & Wosinska, 2014) introduces a comprehensive TCO evaluation model for small cells MBH by identifying critical cost drivers affecting CapEx and OpEx. (Zefreh, Tizghadam, Leon-Garcia, Elbiaze & Miron, 2016) proposes a MILP model to minimize CapEx for multi-chassis routers and multi-rate line cards in IP over optical networks. Their proposed optimization is limited to initial (day one) CapEx calculation while OpEx was not considered.

### **1.2.2 Multi-tenancy and Network slicing in 5G MBH**

Multi-tenancy and network slicing are novel approaches to offer service-aware and cost-efficient 5G networks. (Costa-Requena, Santos & Guasch, 2015) emphasizes on the importance of integrating recent SDN (Software Defined Networking) and NFV (Network Function Virtualization) concepts in optimizing 5G MBH resources and saving up to 14% of CapEx. (Kholdashenas et al., 2016) presents infrastructure multi-tenancy within 5G SESAME project by sharing the physical resources among various MNOs, service providers and Over-the-Top (OTT) users. (Mur et al., 2016) presents a network slicing solution based on dynamic partitioning and sharing physical resources among several virtual networks. (Zhou, Li, Chen & Zhang, 2016) introduces the concept of hierarchical Network Slicing as a Service (NSaaS) where customized end-to-end network slices are offered to MNOs as a service with enhanced slice management and quality assurance mechanisms. (Sama, Beker, Kiess & Thakolsri, 2016) discusses requirements of coming applications and services in 5G era and propose a new mechanism for multiple slicing based on required service type. (Bakhshi & Ghita, 2016) defines six unique traffic profiles based on NetFlow, cluster analysis and users application usage trends for future networks monitoring, policy enhancement and anomaly detection. Nevertheless, these solutions are not considered in TCO analysis. They rather rely on deterministic connectivities with static resource allocations and service-agnostic pipes. Resources are transparently allocated regardless of service SLAs and revenues. The pricing of traffic profiles is not considered in the costs of user interfaces and results in unfairness in TCO calculation. A wiser and more

adaptive service-aware resource activation should be defined to reduce CapEx and OpEx and enhance 5G network scalability.

### **1.3 Optimizing 5G MBH Profitability by Network Virtualization and Game Theory**

#### **1.3.1 Cost reduction methods**

The offered SLAs are depending on network capacity and available QoS. The compromise between optimal investment costs and decided service pricing strategy is a challenging planning question for MNOs. In particular, several efforts were carried out in previous works to optimize the infrastructure resources and drop the costs of coming 5G optical backhaul networks. However, most of the focus was offered to the technical issues until some recent studies that has been carried out on the economic aspects in optimizing MBH networks. In this section, we review various related works and their contributions.

(Zefreh, Tizghadam, Leon-Garcia, Elbiaze & Miron, 2014) introduce a Mixed Linear Integer Program (MILP) optimization algorithm to generate - while minimizing CapEx - a detailed Bill of Materials (BoM) and an optimum network design in IP over DWDM transport networks. The model takes as input several parameters such as i) network topology, ii) traffic demand matrix and iii) prices of various network elements./cards/modules for multi-chassis routers with multi-rate line cards. German and US backbone sample networks are used as examples to evaluate performance of the proposed heuristic method and compare the generated BoM with realistic ones.

(Mahloo, Monti, Chen & Wosinska, 2014) present a comprehensive cost modeling methodology to assess the TCO of MBH networks including both microwave and fiber technology options. The authors introduce a first complete assessment of the entire TCO and the impact of a given backhaul technology on a HetNet deployment using small cells. Detailed CapEx and OpEx breakdown is proposed and can be used for different backhaul technologies and architectures. The model is applied on the MBH of a dense urban area over a 20-year time period.



Results show the impact of MBH technology and HetNets density on the MBH TCO. Fiber remains the most promising technology for backhaul for dense HetNets thanks to its scalability and high capacity.

### 1.3.2 Network Virtualization

(Knoll, 2015) defines a detailed techno-economic model for LTE networks including a novel comprehensive TCO analysis for real and virtualized network components. Various project life-cycle phases are considered in the TCO calculation. CapEx and OpEx cost models take into account various SDN/NFV based scenarios: i) equipment can be owned or rented, ii) real or virtual devices, iii) globally or individually, and iv) VNFs running on top of Virtual Machines (VMs) can be outsourced/rented based on a VNF-as-a-Service (VNFaaS) model. The model development and result analysis are done using the software “Strategic Telecoms Evaluation Model (STEM)” over a 5 years runtime. The resulting CapEx and OpEx cost analysis investigates the profitability of a fully virtualized versus a traditional mobile network. Yearly accumulated TCO results are summed up over the run period for fully owned or rented data-center resources. Nevertheless, cost values are based on assumptions and market forecasts with around 20% uncertainty. Table 1.1 summarizes these various scenarios that will be considered in our evaluation study in Section 4.5.

(Bouras, Ntarzanos & Papazois, 2016) present a techno-economic analysis for the integration of state of the art technologies such as SDN, NFV and Cloud Computing in 5G mobile networks. CapEx and OpEx are compared between traditional and the proposed network architecture to estimate TCO based on the number of deployed Base Station (BS) sites in Sweden. First, the model is applied on traditional BS deployment with 10, 20, 30, 50, 80, and 100 physical BSs. Second, the model is applied on the proposed network architecture where up to 6 Virtual BSs (vBS) are deployed on one physical Software-based BS (SBS). Results show that virtual network architecture offers a significant TCO reduction compared with traditional deployments (OpEx, CapEx, and thus TCO are reduced by 60+% in comparison with the traditional network scenario.)



Table 1.1 CapEx and OpEx for Hardware (HW) and Software (SW) components in Traditional and Virtualized MBH network

<b>Type</b>	<b>Fully owned Traditional MBH</b>	<b>Fully owned Virtualized MBH</b>
$CapEx^{HW}$	Traditional GPON CPEs OLT racks and basic hardware Traffic modules, switching fabric Power and management modules Installation / deployment fees	Commodity GPON CPEs Access racks and I/O blades Commodity servers Spine and leaf switches Installation / deployment fees
$CapEx^{SW}$	Fully loaded equipment software	<b>VNF deployment costs</b> <b>VNFs one-time license fees</b>
$OpEx^{HW}$	Spare parts and warranty Right-to-Use and license keys	Spare parts and warranty Right-to-Use and license keys
$OpEx^{SW}$	Network managed services System maintenance costs	VNF maintenace costs Software and certificate update
<b>Type</b>	<b>Renting servers in V-MBH</b>	<b>Renting VNF-as-a-Service</b>
$CapEx^{HW}$	Commodity GPON CPEs Access racks and I/O blades	Commodity GPON CPEs Access racks and I/O blades
$CapEx^{SW}$	<b>VNF deployment costs</b> <b>VNFs one-time license fees</b>	
$OpEx^{HW}$	<b>Servers annual rental fees</b>	<b>Servers annual rental fees</b>
$OpEx^{SW}$	VNF maintenace costs Software and certificate update	<b>VNFs annual rental fees</b>

### 1.3.3 Game Theory

The price competition among various 5G host MNOs is based on a **non-cooperative game** since the regulations do not allow the competing MNOs to share among them any information about their pricing strategies. Thus, each competing MNO is a rational player that tries to build his best pricing strategy based on the best responses of other competing players without a common-knowledge scenario. In this context, (Yu & Kim, 2014) present a game theoretic compromise of the quality versus price competition among MNOs and analyse the price dynamics in a real world. An optimization problem is defined based on a two-stage competition model combining Cournot (quality and investment) and Bertrand (price and revenue) competi-

tion games. The outcome is an equilibrium point between the quality of service (QoS) offered by MNO networks and the competing service prices driven by end-users. The authors emphasize on the importance of defining *"how much of the network capacity should be provisioned and how high the service price should be"* (Yu et al., 2014). The authors recommends a simple regulation rule that guarantees an equilibrium point of price levels (Pareto optimal price) to drive effective resource planning and optimum network investments. Nevertheless, the quantities of resources dedicated by competing host MNOs are normalized (fixed) and are not fairly following the project deployment pace as in real world. The prices of offered services are not considering the different traffic profiles that may be priced differently as well. Thus, the yearly dedicated quantities and related prices need to be generalized in the definition of the competition game and the resulting pareto-equilibrium prices to consider their yearly evolution for different tenants and different service types over the project life cycle.

#### **1.4 Discussion**

Planning scalable 5G MBH transport networks becomes one of the most hard and challenging issues. The migration from massively deployed legacy networks to recent all-IP based solutions is promising but very challenging. There is no efficient mechanism to optimize the deployment and assignment of network resources on yearly basis based on required traffic demand and generated service revenues. Heavy routing protocols in the core network are very expensive and are consuming valuable power and space. Thus, most of traffic crossing L3 IP/MPLS domain need to be offloaded to lower layers of the OSI reference model. Consequently, transport networks are costly and not fully exploited. This results in waste of capacity and affect the network scalability and profitability. Yet, existing planning solutions are no longer appropriate for coming 5G requirements. With a target to reduce the TCO and improve the scalability and profitability of optical MBH networks, prior work focused on the choice of the most efficient and cost-effective technologies as well as the optimization of the number of planned network elements and related costs.

On the other hand, multi-tenancy and network slicing based on virtualized resources are promising solutions to satisfy MBH network greediness while reducing related expenditures. Lower layer networks (in OSI model) have always been considered as dumb and transparent transport pipes without being monetized. Existing TCO analysis are not fairly considering Service Level Agreements (SLA) between MNOs and their customers. Cost calculation models in prior work are driven by initial estimated hardware quantity and prices. Costs of basic equipment and related modules (subrack, management and power modules, switching fabric, user interfaces, etc) are all considered in the initial cost calculation even before they actually carry traffic and generate revenue. Their TCO models do not scale with the growth of service and generated ROI (Return On Investment). There is no appropriate model that fairly distributes costs over multiple virtual operators, and also optimizes physical resource planning. Continuous expansion of MBH physical networks based on current cost models will drastically increase network TCO for future very high density 5G networks. Cost models do not consider the Average Revenue Per User (ARPU) values generated by satisfying each connected Tenant Service Instances (TSI) and the total ROI generated by yearly activated network services.

In order to meet the emerging requirements of future 5G high-density and random cellular architecture, there is an urgent need to efficiently build and operate future 5G Mobile Backhaul networks (MBH) with minimum costs and higher scalability. Innovative planning tools based on dynamic activation, pay-as-you-grow pricing and yearly distribution of traffic demand need to be developed to avoid over-provisioning infrastructure. This will help split project costs over several years and avoid high kick-off project budgets. Moreover, costs of various service-aware traffic profiles have to be taken into account according to different end-user Service Level Agreements (SLA) and generated revenues. The project profit margin ( $PPM = ROI - TCO$ ) need to be optimized based on the estimated traffic demands, the time and quantity of yearly activated MBH resources as well as the generated ROI. The different types and costs of activated traffic profiles as well as virtualization of network resources need to be considered in the PPM optimization models. The wholesale prices used by MNOs to lease connectivity links

within the MBH and used to generate the ROI need to be further optimized using appropriate game theory models.

Thus, the methodology of our workframe to enhance the scalability and profitability of coming 5G MBH network can be summarized as:

- We present a practical transformation experience for a real service provider towards an *End-to-End Integrated Optical Packet Network (E2-IOPN)* as a first necessary step for next generation reliable and low-cost MBH networks. We conduct a detailed empirical analysis of the various challenges and issues faced by a real service provider *SP* in his network modernization towards a more advanced and cost-effective E2IOPN network.
- We define a comprehensive high-level design (HLD) as implemented by that service provider *SP* that considers the integration (hand-shake) and inter-operability solutions between various technologies used within E2IOPN layers. We assure a detailed CapEx and OpEx comparative study between different optical technologies that may be used within E2IOPN.
- We introduce a novel algorithm based on Voronoi Tessellation diagram to more precisely define the backhauling zones within a geographical area and optimize their estimated Total Traffic Demand (TTD) in each zone for more accurate TCO analysis.
- We define a comprehensive CapEX and OpEx calculation model for optical T-MBH networks. We propose a novel TCO analysis method called BackHauling-as-a-Service (BHaaS) based on "You-pay-only-for-what-you-use" to optimize the yearly planned deployment and activation of resources based on a given traffic demand and related generated revenues.
- We enhance the previous BackHauling-as-a-Service (BHaaS) method by a more service-aware method called **Traffic-Profile-as-a-Service (TPaaS)** that further optimizes the TCO by considering the various costs of different traffic profiles.
- We propose a detailed CapEX and OpEX cost formulation for SDN/NFV based 5G multi-tenant virtualized MBH (V-MBH). We introduce a novel pay-as-you-grow and service-aware optimization model called **Virtual-Backhaul-as-a-Service (VBaaS)** as a planning

tool for future V-MBH projects to optimize the PPM and the yearly deployment and activation of software and hardware components.

- We define a price competition game called **MNO Pricing Game (MPG)** to model the interaction between resource activation and price strategies of multiple competing MNOs in order to calculate the optimal Pareto-Equilibrium prices for offered backhauling services.



## CHAPTER 2

### TOWARDS END-TO-END INTEGRATED OPTICAL PACKET NETWORK: EMPIRICAL ANALYSIS

Nassim Haddaji<sup>1</sup>, Kim-Khoa Nguyen<sup>2</sup>, Mohamed Cheriet<sup>1</sup>

<sup>1</sup> Department of Automated Production Engineering, École de Technologie Supérieure (ETS),  
1100 Notre-Dame Ouest, Montréal, Québec, Canada H3C 1K3

<sup>2</sup> Department of Electrical Engineering, École de Technologie Supérieure (ETS),  
1100 Notre-Dame Ouest, Montréal, Québec, Canada H3C 1K3

Article published by Elsevier, "Journal of Optical Switching and Networking", June 2017.  
Digital Object Identifier: 10.1016/j.osn.2017.06.003

#### 2.1 Abstract

Today, the overloaded networks increasingly entail high operational costs but may not generate new revenues accordingly. Legacy network elements are reaching end-of-life and packet-based transport networks are not efficiently optimized. Thus, an efficient migration plan towards an End-to-End Integrated-Optical-Packet-Network (E2-IOPN) is emerging for service providers in access, metro and core networks. This paper reviews various empirical challenges faced by a Service Provider (*SP*) during the transformation process towards E2-IOPN as well as in the implementation of an as-built plan and high-level design for migrating towards GPON, MPLS-TP, OTN and next-generation DWDM. Then, we propose a *SP* longer-term strategy based on SDN and NFV approach that will offer rapid end-to-end service provisioning and centralized network control. Such strategy helps *SP* maintain good profit margin and best customer experience. A cost comparative study shows the benefit and financial impact of introducing new low-cost packet-based technologies to carry legacy as well as new services traffic.

**Keywords:** GPON, MPLS-TP, OTN, DWDM, MLO, QoS, SDN/NFV.

## 2.2 Introduction

The residential and enterprise customers require different kind of services in service providers networks (Cao, Y. Zhang, J. Zhang, Cheng & Gu, 2010). In particular, mobile backhaul networks (2G/3G/4G) represent as well a big part of *SP* connectivity services. Different Service Level Agreements (SLAs) and traffic constraints (bandwidth, priority, latency and resiliency) need to be considered carefully by *SP* designers. Rapid time-to-market service requires dealing with legacy administrative processes based on manual provisioning (Polito, Zaghoul, Chamaania & Jukan, 2011). North-Bound Interfaces (NBI) based end-to-end service management systems, like OSS/BSS (Operation Support System / Business Support System) applications might be a possible solution (Thyagaturu, Mercian, McGarry, Reisslein & Kellerer, 2016). So far, they still need automatic resource optimization and programmable real-time monitoring (Bitar, 2011) and (Muoz, Casellas, Martnez & Vilalta, 2012). While many current service provider networks already stopped being profitable (Nowell, 2009) and (Kachris & Tomkos, 2012), some others may still increase their costs by expanding pipe capacities to deal with the bandwidth requirements of new services. Only services with differentiated prices can generate new revenues and reverse the end-of-profit trend. Future networks need to be smart networks to serve next generation smart services (Btar, 2011). Legacy networks are therefore required to be re-designed and dumb pipes control would have to be replaced by resources monetization and new innovative business models. We present in this paper a real service provider *SP* practical transformation experience towards an *End-to-End Integrated Optical Packet Network (E2-IOPN)* that represents the necessary infrastructure for next generation smart networks. Note that this transformation strategy was implemented in *SP* network after long literature studies and market analysis with various technology partners, solution suppliers and equipment manufacturers in the telecoms industry.

Recent research in the field proposed standard perspective to optimize resources planning by focusing on the contributions and the impact of the IEEE, ITU, and IETF standards in the lower layers of the telecommunications stack such as Wavelength Division Multiplexing (WDM), Carrier Grade Ethernet (CGE), Optical Transport Network (OTN), Multi-Protocol La-



bel Switching (MPLS) and MPLS-Traffic Profile (MPLS-TP) (Gumaste & Akhtar, 2013) and (J. Sommer, et al., 2010). However, they do not discuss challenges and solutions to achieve such transformation plan. In this paper, we address technical challenges that most service providers are facing to build their migration plan toward the E2-IOPN, in particular, to compensate the lack of detailed standardization. Criteria for network design (routing, propagation across the network and deployment of higher-layer protocols) are discussed in (Mathew, Das, Gokhale & Gumaste, 2015) including cost considerations. In reality, transforming all legacy network components and the way they are managed to an E2-IOPN is very challenging. While monitoring the compromise between transformation costs and new revenue streams, *SP* needs to deal also with classic design challenges such as traffic shaping, bandwidth optimization and network resiliency. New challenges related to the complexity of recent mobile technologies (coming 5G for instance), smart services requirements and user Quality of Experience (QoE) are making this design exercise more complicated task (Donovan & Conroy, 2008) and (Fiorelli et al., 2014). With the explosive migration towards All-IP services, legacy Time Division Multiplexing (TDM) technologies are phasing out as their rigid pipes are no longer efficient for packet-based services (Donovan et al. 2008) and (Chun, Kwon, Kim & Song, 2014).

Along with the increasing number of residential (and small business) applications, the bandwidth and Quality of Services (QoS) offered to current quadruple-play services by legacy Digital Subscriber Lines (DSL) solutions is not anymore sufficient. Copper cables in the last mile need to be re-placed by fiber. DSL technology needs to be migrated to GPON (Gigabit Passive Optical Network) based FTTH (Fiber-To-The-Home) networks (Maes, Guenach, Hooghe & Timmers, 2012), (Sommer, et al., 2010), (Murakami & Koike, 2014), and (Effenberger et al., 2007). In this paper, we investigate detailed FTTH design based on GPON technology and related Out-side Plant (OSP) part. To manage millions of Customer Premise Equipment (CPE) and to monitor the related millions of fiber optical cables, a network should be designed in a scalable fashion, for instance, using TR-069 Auto-Configuration Server (ACS) (Wang, Chen, Hsu, Hsu & Young, 2016) and (Wu, Chan, Chen & Chu, 2012) and Optical Time Domain Reflectometer (OTDR) based Optical Fiber Monitoring System (OFMS) (Schmuck, Straub,

Bonk, Hehmann & Pfeiffer, 2014). TR-069 is a CPE management protocol offering GPON CPE auto-configuration, dynamic service provisioning, remote Software and firmware management as well as diagnostics, status and performance monitoring (Hillen, Passchier, Matthijssen, Den Hartog, & Selgert, 2008). OTDR is a fiber characterization technology deployed in core and metro networks to characterize point-to-point fiber cables and to report all types of fiber modifications (e.g., breaks, attenuation, extension and reflectance). Both help improving network availability and reducing fault detection and localization time from hours and days to few minutes (Ehrhardt, Schuerer, Escher, Nagel & Foisel, 2013) and (Dalela et al., 2015). We present in this paper a recent solution to deploy OFMS system to address GPON based FTTx networks and perform OTDR measurements crossing passive splitters.

Although many service providers are still mapping their last-mile traffic to PDH (Plesiochronous Digital Hierarchy), SDH (Synchronous Digital Hierarchy) and SONET (Synchronous Optical Network) containers of different fixed sizes, new all-IP burst traffic is being moved to elastic all-packets transport networks (Chun et al., 2014) and (Murakami et al., 2014). MPLS-TP and OTN are low-cost multi-service carrier-grade Ethernet solutions with SDH-like OAMP (Operation, Administration, Maintenance and Provisioning) mechanisms (Sommer, et al., 2010), (Murakami et al., 2014), (Malis, 2012) and (Beller, Dieter & Sperber, 2009). The migration from massively deployed SDH in metro networks to new MPLS-TP based solutions is promising but very challenging (Huang, Yi, Zhang & Gong, 2008). Timing, traffic engineering and inter-operability issues need to be addressed in this migration (Choi, 2016) and (Chamania & Jukan, 2009). Service creation in MPLS-TP is usually done statically by Network Management Systems (NMS) (Muoz et al., 2012), (Huang, Yi, Zhang & Gong, 2009) and (Martinez, Casellas & Muñoz, 2012). Transmission teams - used to the concept of cross-connections of virtual containers - need consistent training to ramp up in dealing with elastic packet-based pipes. Moreover, there is no mechanism to efficiently classify the traffic and optimize the assigned capacities. Consequently, transport networks are costly and not fully utilized. This results in waste of capacity and traffic congestion, thus affecting the end-customer experience.

In the core transport network, also known as backbone, almost all traffic is unnecessarily transiting the core routers through routed layer 3 (L3) tunnels or L3 Virtual Private Networks (VPN). Heavy routing protocols in the high-cost IP/MPLS routers are not only consuming valuable power and space, but also introducing high latency affecting delay-sensitive applications. Thus, service providers are facing a big scalability issue that needs to be solved by offloading traffic to lower layer (in the OSI (Open Systems Interconnection) reference model) technologies (Rambach, et al., 2013). Statistics show that 70% of traffic crossing L3 IP/MPLS domain has a deterministic traffic pattern (Murakami et al., 2014), and thus does not need to be routed (Chun et al., 2014), (Hutcheon, 2011) and (Martínez, Casellas, Muñoz & Vilalta, 2011). Instead, this traffic needs to be re-directed to much lower-cost, lower latency and higher availability OTN and DWDM (Dense Wavelength Division Multiplexing) based networks (Donovan et al., 2008), (Hutcheon et al., 2011), (Santos, Pedro, Monteiro & Pires, 2011) and (Bertolini, Rocher, Bisson, Pecci & Bellotti, 2012). Lower layer networks have been always considered as dumb transport pipes forwarding upper layers traffic with total transparent manner. All kind of customer monetized services have been always handled and routed by L3 routers up to destination. High-profile L3 engineers need to migrate also to the new concept of OTN-based monetized network resources to reduce the cost of transported services (Zhu, Chang, Wang & Fang, 2012). Huge traffic engineering effort has to be paid to classify each traffic and map it in a deterministic way to switched Optical Data Units (ODUs).

To increase visibility and flexibility in the network control plane, SDN (Software Defined Networks) and NFV (Network Function Virtualization) architecture is recently emerging. We discuss *SP* long-term strategy based on the concept of a centralized control-plane in Integrated Optical Packet transport networks using a programmable Path Computation Engine (PCE) that should provide a faster and more dynamic end-to-end bandwidth-on-demand provisioning (Polito et al., 2011), (Thyagaturu et al., 2016), (Choi, 2016), (Chamania et al., 2009) and (Muñoz, Casellas, Martínez & Vilalta, 2014).

The main contributions of this paper are:

- An empirical analysis of various challenges and issues faced by real service providers *SP* and mobile network operators (MNO) to migrate their brown-field legacy transport networks into more advanced E2IOPN
- A comprehensive as-built high-level design (HLD) as implemented by *SP* including practical integration (hand-shake) and inter-operability solutions between the various E2IOPN layers. An algorithm for automated ONT remote activation and a cost comparative study are also proposed.
- An SDN/NFV based longer-term strategy, and a *Throughput driven Real-Time Traffic Engineering (TRT-TE)* architecture as a novel centralized control plane to efficiently carry out real-time Traffic Engineering and minimize TCO for E2IOPN.

The remainder of this paper is organized as follows. In Section 2, we review the state-of-the-art of transport network technologies in access, metro and core networks. Then, in Section 3, we discuss the transition technical issues towards E2-IOPN and challenges faced by service providers in the industry (in particular, our service provider *SP*). In Section 4, we analyze each component of the transport network and make a survey on empirical solutions and technologies implemented by *SP* for a smooth and efficient migration plan towards an efficient E2-IOPN. In Section 5, we evaluate the importance of good network transformation strategy towards E2-IOPN through numerical comparative study showing cost benefit offered by discussed vision in the metro as an example.

### **2.3 THE STATE-OF-THE-ART OF TRANSPORT NETWORKS**

The E2-IOPN is addressing end-to-end service provisioning and quality monitoring across all layers of the transport networks (Polito et al., 2011). The discussion is addressing all parts of the network starting from access and metro backhaul networks to core transport networks. Figure 2.1 summarizes the various technologies and related components within the different layers in the legacy networks. In fact, DSL lines were widely deployed in the access to connect the different services end-users in the last-mile layer. Stacked SDH rings used to be the main

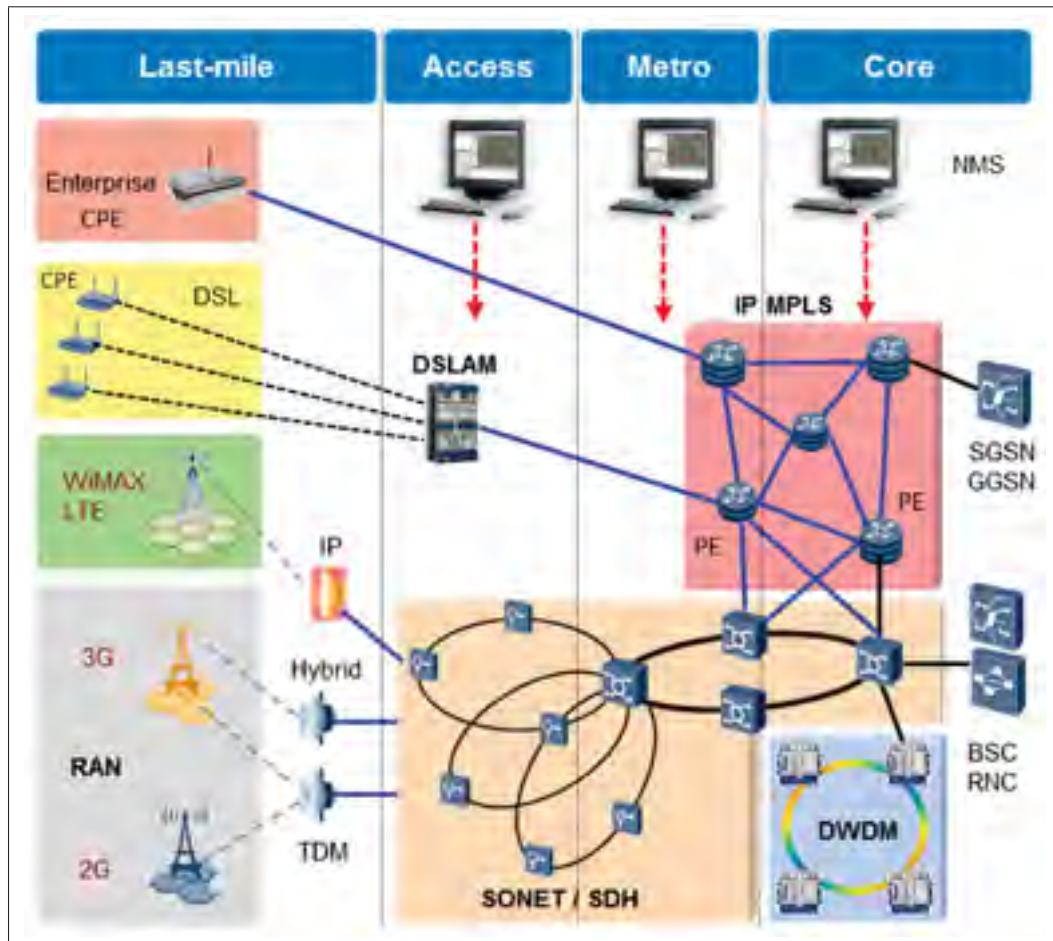

Figure 2.1 *SP* legacy transport networks architecture

transport technology in the backhaul and metro networks to forward the traffic from the access aggregation components to the core. The core network is based on IP/MPLS core routers connected together in a mesh by higher granularity SDH containers over DWDM wavelengths or directly by DWDM links (IPoDWDM). Each layer and each technology of the legacy network used to be managed and controlled by separate Management Systems from different vendors.

### 2.3.1 Access layer

Most of the service providers are still using already massively-deployed copper-based technologies (e.g. ADSL2+ and VDSL2) for residential Triple / Quadruple play customers as well

as Ethernet-based leased lines for small enterprise and business customers. The last-mile network within the access layer provides interfaces of several Mbps to these end-users. These customers are usually connected to an aggregation equipment (called DSLAM for Digital Subscriber Line Access Multiplexer) in a star (hub-and-spoke) topology. As detailed in Figure 2.2, DSL customers can be connected directly to the DSLAM located in the Central Offices (CO) if they are close or to smaller mini-DSLAMs located inside Active Street Cabinets to increase the reach (in case of longer distances). Aggregated traffic is forwarded by the DSLAM to the IP based core network.

In the mobile backhaul network, the traffic pattern in 2G/GSM BTS, 3G/UMTS NodeB and 4G/LTE eNodeB is in general also forming a star topology with the core network (Base Station Controller BSC, Radio Network Controller RNC and enhanced Packet Core ePC). Most of Mobile Network Operators (MNO) are still using already massively-deployed TDM-based SDH technology to collect traffic coming from Radio Access Networks (RAN). However, FTTH technologies (e.g. GPON, NG-PON and WDM-PON) are emerging and offering low cost-per-bit solutions and almost unlimited bandwidth. While NG-PON and WDM-PON standards are still lacking maturity, FTTH networks based on GPON technology are achieving a lot of success for residential and small business customers. The number of deployed GPON networks is increasing exponentially (Maes et al., 2012), (Murakami et al., 2014) et (Effenberger, et al., 2007). They have been used by several MNOs as the main mobile backhaul solution regardless of their limited scalability and reliability (Verbrugge et al., 2008).

Moreover, MPLS-TP technology was recently introduced as more suitable solution, replacing SDH and SONET in both access and metro networks as highlighted in Figure 2.4. In particular, MPLS-TP is becoming the promising solution regarding backhauling 2G, 3G and 4G traffic (Bitar, 2011) and (Sommer, et al., 2010). Service providers (in particular, MNOs) are gradually phasing out their SDH/SONET networks and migrating to MPLS-TP technology. Nevertheless, some enterprise customers (education, government, industrial and financial sectors) with delay-sensitive applications and no tolerance to shared network resources (like in GPON and MPLS-TP), strongly require higher capacity (up to 10 Gbps) and dedicated low-



latency connectivity. In these particular cases, direct point-to-point Active Ethernet (ptp-AE) link is commonly offered as alternative low-cost solution. Service providers may also adopt a wavelength-to-an-enterprise vision or a “spectral slice to a user” as a more efficient but more expensive solution (Kachris et al., 2012) and (Gumaste et al., 2013).

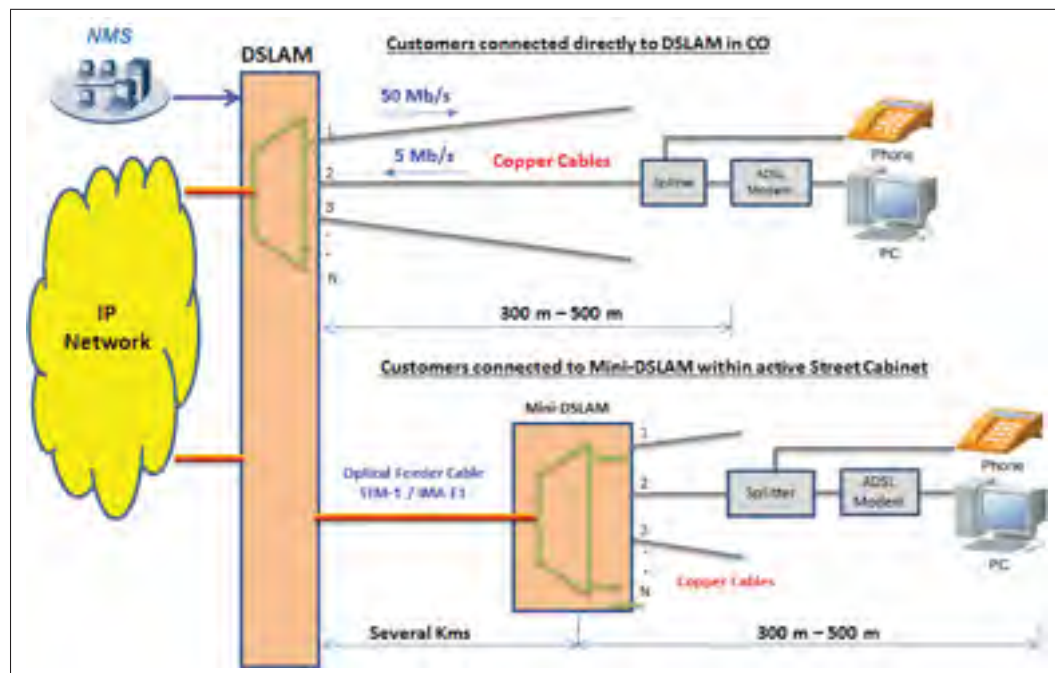

Figure 2.2 Current DSL based last-mile network

### 2.3.2 Metro layer

The metro layer connects different sites inside metropolitan areas with speeds up to 100 Gbps are required. Depending on the size of the metropolitan networks, service providers are usually splitting the metro layer to metro access, metro aggregation (or edge) and metro core. The sites can be different Point-of-Presence (POP) or COs belonging to the same service provider. All traffic coming from the access layer is aggregated in the POP and forwarded to the core network (Rambach, et al., 2013). The sites can also be different offices belonging to the same enterprise connected through an L2 or L3 VPNs. Although most of the service providers are migrating this layer to pure Ethernet-based packet technologies, several metro networks are

still based on legacy SDH and more recent MSPP (NG-SDH) as shown in Figure 2.1. In MSPP, Ethernet traffic is mapped over SDH virtual containers using GFP (Generic Framing Procedure) adaptation protocol (Gumaste et al., 2013) and (Huang et al., 2008). Until very recently, SDH and its flavors were the dominating transmission networks thanks to their strong OAM tools. These tools offers high efficiency for TDM voice as well as high QoS and security for low-rate data traffic (Sommer, et al., 2010).

SDH technology is phasing out due to its rigid TDM-based pipes (Chun et al., 2014). There are emerging Carrier-Grade Ethernet (CGE) technologies to replace SDH in the metro access and metro aggregation layer, like PBB-TE (Provider Backbone Bridge / Traffic Engineering G802.1ah) (Gumaste et al., 2013) or MPLS-TP in which MPLS-TP would be the promising one (Cao et al., 2010), (Sommer, et al., 2010) and (Murakami et al., 2014). As in the access networks, MPLS-TP, which can be defined in a simplest way as the Transport Profile of IP/MPLS, is gradually replacing SDH (Choi, 2016). It is an Ethernet-based low cost solution that offers required performance, scalability, and especially CapEx (CAPital EXpenditure) and OpEx (OPERation EXpenditure) reduction (Rambach, et al., 2013). It offers multi-service adaptation and high bandwidth utilization thanks to statistical multiplexing. It also provides simple and user-friendly plug-and-click provisioning using Graphical User Interface (GUI) portals. MPLS-TP provides strong SDH-like resiliency mechanisms (less than 50 ms, 1:1 LSP protection, PW APS...) as well as pro-active carrier class OAM tools with strong QoS schemes. It offers also PTP IEEE 1588 Precise Timing Protocol for LTE network synchronization (Huang et al., 2009) and (Golnari, Shabany, Nezamalhoseini & Gulak, 2015).

Recently, OTN switching is also gaining a lot of attention in metro networks (Donovan et al., 2008) and (H. Lee, K. Lee, Na & Y. Lee, 2014). Thanks to its robust multi-service transport infrastructure scaling from 1 Gbps up to 100 Gbps, OTN is now recognized as the next generation switched transport solution for multi-service packet optical networks in the core, metro core and even metro aggregation layers. Furthermore, few service providers have even started deploying OTN down to the access network for business customers' use cases where no sta-



tistical multiplexing is required and where bandwidth granularity is starting from 1 Gbps and beyond.

### 2.3.3 Core layer

In the core network, services are often routed by IP/MPLS Provider routers (known as P routers). Traffic coming from the metro networks is first received by Provider Edge (PE) routers that map pure IP traffic into MPLS tunnels. A number of 40 Gbps and 100 Gbps optical interfaces are connecting the IP core routers in mesh topology or in multiple connected rings on top of the huge long haul and ultra-long haul DWDM transmission bandwidth (Roy, Turkcu, Hand & Melle, 2014). To increase reliability, service providers often use mesh topology to have more efficient protection and restoration mechanisms. IP/MPLS network offers good control but relatively high cost per port, which limits growing networks scalability (Rambach et al., 2013). Also, delay-sensitive applications are strongly affected by the huge latency introduced by the heavy routing processes. Statistics show that more than 70% of the traffic remains inside the metro network or does not need to go to IP core layer thanks to its deterministic traffic pattern. This traffic is mainly connection-oriented and is unnecessarily crossing the IP/MPLS network. It should be offloaded to lower layers (Cao et al., 2010).

Thanks to its robust multi-service transport infrastructure scaling from 1 Gbps up to 100 Gbps per wavelength, several service providers are gradually introducing OTN in their core networks by offloading deterministic traffic to lower layers using ODU switching on top of 40 Gbps and 100 Gbps DWDM links. Service providers have to maximize the value of each technology in the network and enable traffic transport at the most cost-effective layer (Yin et al., 2012). MPLS-TP traffic coming from access and metro access networks is also groomed in ODU-x ( $x=1..4$ ) switched tunnels. On the photonic layer, 40 Gbps and 100 Gbps DWDM wavelength channels are currently carrying OTN groomed ODUs (Donovan et al., 2008) and (Lee et al., 2014).

As one of the most promising solutions for next-generation optical networks, Elastic Optical Networking (EON) offers dynamic and on-demand spectrum resource assignment to next-generation core networks. Using Bandwidth-Variable Transponders (BVT) and Spectrum Selective Switches (SSS), connection services are mapped into dedicated slots within standardized flexible spectral grid (from 6.25 and 12.5 GHz sub-wavelength up to 400 GHz super-channels and beyond). Lightpath is transmitted over single-carrier or coherent Optical Orthogonal Frequency Division Multiplexing (CO-OFDM) transmission schemes. Recently, legacy GMPLS based Routing and Spectrum Assignment (RSA) mechanisms are migrating to more flexible and programmable GMPLS/PCE and SDN based control planes. Service provisioning calculation in core networks is moving to centralized Path Computation Element (PCE) in the Software Defined EON (SD-EON) architecture (Liu et al., 2014), (Iovanna, Ubaldi & Di Michele, 2014) and (Chen et al., 2016).

#### **2.3.4 Control layer**

Currently, the network control layer is based on i) separate Network Management Systems (NMS) to control and manage each network domain as shown in Fig. 2.1 and ii) several control plane protocols embedded within the devices themselves to communicate among each other. Most of the time, each vendor NMS is using proprietary interfaces and protocols to communicate with the same vendor network devices. In several cases, this vendor is having separate NMS for each kind of technology. The network control layer is becoming very complicated with different network islands managed by different NMS systems. This is causing a number of inter-operability and inter-domain service provisioning issues (Chamania et al., 2009). For more flexibility and efficiency, operators are migrating to SDN/NFV based unified and centralized network control. SDN architecture is based on decoupling the control plane of network elements from the hardware, and implementing it in upper software-based layers. Only data plane (forwarding plane) remains in the network devices. This architecture efficiently reduces complexity and cost of the network infrastructure and thus, solves the increasing network scalability issue. NFV concept is based on virtualizing several network functions (routing, firewall,

encryption, etc) and shifting the network intelligence to cloud-based building blocks, called Virtual Network Functions (VNFs) (Thyagaturu et al., 2016). Totally offloaded from legacy dedicated hardware, these VNFs reside in one or more virtual machines in IT virtualized environments (Thyagaturu et al., 2016), (Liu, 2014), (Li & Chen, 2015) and (Cyan Inc, 2014). More details about SDN architecture and its features are discussed in Section 5.

In particular, new control plane designs are emerging to offer more flexibility and programmability to SD-EONs. (Liu et al., 2014) investigate the performance and validate the feasibility of EON architecture based on low-cost Direct-Detection Optical OFDM (DDO-OFDM) scheme in core networks under OpenFlow-based SDN control plane. (Zhu et al., 2015) introduce a novel inter-domain protocol (IDP) design and a multi-domain cooperative RSA algorithm for SD-EON multi-domain use cases. (Giorgetti, Paolucci, Cugini & Castoldi, 2015) propose a novel Hierarchical PCE (HPCE) architecture that uses BGP-LS (Border Gateway Protocol - Link State extension) to pro-actively update the parent PCE (pPCE) and offer end-to-end inter-domain service provisioning. Intra-domain path calculation remains under the custody of local child PCEs (cPCE). (Chen et al., 2016) discuss the role of competing brokers in OpenFlow based SD-EON cross-domain service orchestration. An effective revenue-driven bidding strategy is proposed to optimize service pricing and increase brokers' profit based on competition behaviors prediction.

## **2.4 Challenges in migrating towards E2-IOPN**

For the last three decades, service providers have massively deployed SDH in the access, metro and core networks to transparently multiplex and transport various services traffic (Figure 2.1). IP/MPLS core routers were connected by SDH links and use dynamic control-plane to route traffic to destinations (Martinez et al., 2011). To offer all-IP services, transport networks need to be adapted to the new traffic requirements and migrate to all-packet based technologies. Transformation towards an E2-IOPN is inevitable to solve scalability issue and afford growing service requirements. In (Gumaste et al., 2013), the authors address issues of bandwidth optimization and recommend smart network planning based on *Packet-optical integration*. The

main goal is to re-design the network to scale with optimized performance whilst keeping CapEx and OpEx as low as possible (Polito et al., 2011). While (Gumaste et al., 2013) focused on standardization challenges to drive network planning as well as product architecture, this paper highlights practical challenges service providers are facing based on the empirical experience of the service provider *SP* during his migration from legacy networks towards E2-IOPN. In next section, we review *SP* As-built plan with respect to access, metro, and core networks and his technical solutions and practical recommendations to be considered during the transport network transformation towards E2-IOPN.

#### **2.4.1 Migration challenges in access networks**

The access networks transformation as part of the E2IOPN plan is presenting a lot of issues for several service providers, in general, and for *SP* in particular. Main challenges can be: 1) lowering the cost for massive fiber deployment, 2) enhancing the fault detection mechanisms, 3) improving the remote configuration and management of ONT (Optical Network Termination) end-user devices installed in customer premises (Verbrugge et al., 2008) and (Agata & Horiuchi, 2009).

##### **2.4.1.1 Out-side Plant (OSP) planning and design**

In order to lower the cost for massive fiber deployment during the migration from existing DSL lines to GPON-based access networks, the first key challenge faced by *SP* is related to the Out-Side Plant (OSP) network. Important planning and design efforts are required to reach and connect every home with fiber cable in a cost effective manner. Digging the pave and installing the fiber cables is consuming a huge CapEx that needs to be optimized in order to maintain *SP* benefit margins. In reality, different areas in the city have different requirements. Residential areas are flat and less dense than business areas. Cable distribution design connecting town houses is horizontal while multi-store and multi-dwelling buildings need a vertical cable distribution design with higher cable density and multi-stage splitting. Cost of digging, installing fiber distribution cabinets and pipes, then blowing the fiber is the most expensive part of the

project. *SP* is a large service provider targeting millions of households. Thus, deep analysis and a proper design (including route length, cabinet locations, splitter location, and number of passive components) are required to optimize the cable routes and required passive components and drastically minimize the OSP cost. Thus, the reduction of CapEx helps also the increase of *SP* profit (Verbrugge et al., 2008), (Ford, Quintal & McCuthy, 1993) and (Agata et al., 2009).

#### **2.4.1.2 Fiber cables monitoring and fault detection**

FTTH network is more vulnerable than long haul network due to the topology of fiber cable routes. Monitoring a huge number of fiber cables reaching every home is becoming critical. *SP* Network Operation Center (NOC) is facing big challenges to detect and locate cable breaks without efficient fiber monitoring solution. Traditional process is to track alarms on NMS, locate affected network segment and send technicians with OTDR movable machine to approximate the fault geographical position. Patrolling team driving time (by car) as well as classic manual OTDR testing may cause a fault location detection time varying from few hours to few days (Ehrhardt et al., 2013), (Honda, Iida, Izumita & Azuma, 2009), (Schmuck, Straub, Bonk, Hehmann & Pfeiffer, 2014), (Verbrugge et al., 2008) and (Verbrugge et al., 2008).

Another issue is related to the use of splitters in FTTH networks. In fact, the GPON network architecture detailed in Figure 2.3 is based on splitting the optical signal through a passive splitter to reduce the number of fiber cables serving the same customers area. Thus, cable fault detection after the splitter using classic OTDR testing becomes technically impossible. Moreover, when a fault occurs, the challenge is to determine whether the fault has occurred on the feeder fiber or on one of the drop fibers (i.e. before or after the optical splitter), and if the fault has occurred within the drop fibers, which one is having problems.

#### **2.4.1.3 CPE activation and management**

Once the OSP network is implemented, the next challenge faced by *SP* was how to automatically activate and remotely manage the millions of Optical Network Terminations (ONT) or

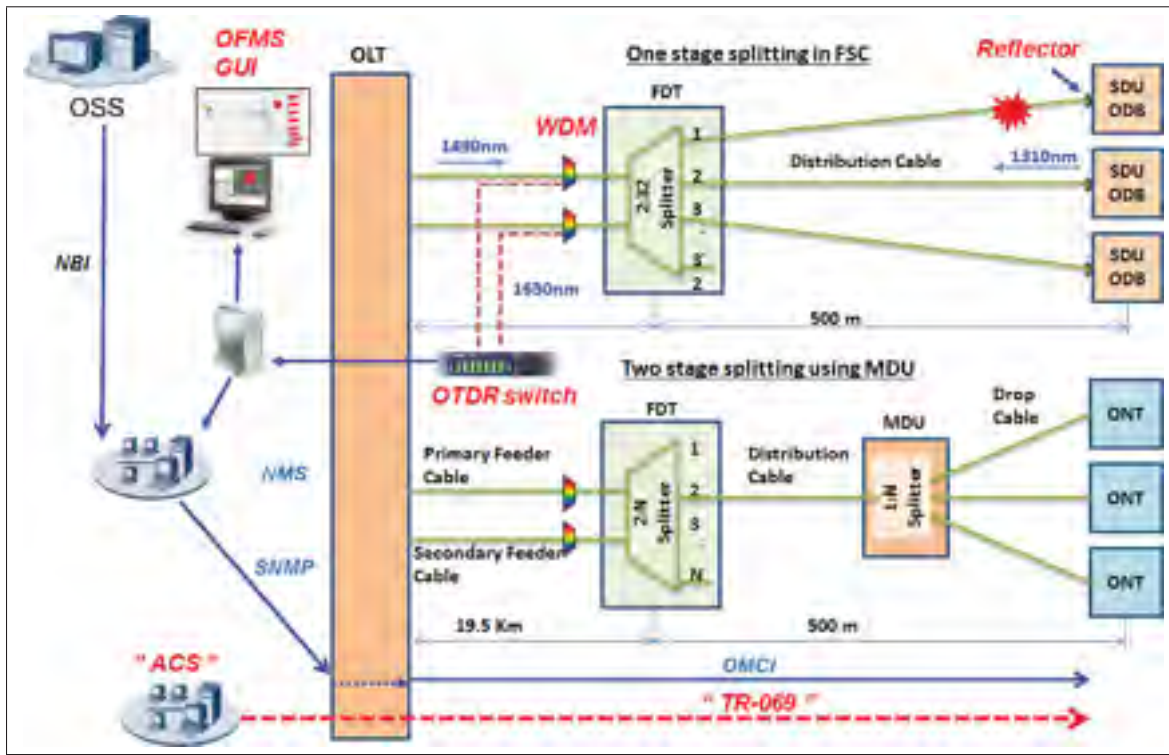

Figure 2.3 SP access network transformation towards GPON based FTTH

Optical Network Units (ONU) without technician visits to customer premises. While the deployment and activation of the end-user CPEs at their homes is a challenge itself, managing and troubleshooting the CPEs in case of failures is an even bigger challenge that can further affect the customer experience and satisfaction. Traditional methods to manage FTTH ONTs are based on the use of ONU Management and Control Interface (OMCI) protocol (ITU-T G.988 standard) which addresses ONU configuration, fault and performance management for CPEs. It includes several services like data, voice and circuit emulation. Limitation is that OMCI protocol relies on layer 2 communication messages between the OLT (Optical Line Termination) and the ONTs. These later equipments must be in general from the same vendor which lead to a lot of inter-operability issues. In particular, SP was pushing his equipment manufacturers for making possible the use of OLTs from vendors X to communicate with ONTs from vendor Y. The reason for that is to ease the distribution of OLTs within districts and assignments of the

customer ONTs per each OLT. CPE remote management and OMCI compatibility were a big challenge (Thyagaturu et al., 2016), (Maes et al., 2012) and (Effenberger et al., 2007).

In order to avoid such compatibility issues, stronger standards are required as discussed in (Gumaste et al., 2013) to control the vendors to implement closely and faithfully existing standards in their products. Without proper solutions and good design, monitoring and troubleshooting all failed ONTs with classic methods cost huge OpEx and reduce the profitability of the network. Moreover, offloading all management and control functionalities from the OLT to an SDN based architecture and using GPON virtual switches is a very recent and attractive approach that is already subject of studies by several service providers and vendors (Thyagaturu et al., 2016). A good example of using SDN/NFV in GPON access networks is the so-called CORD project appeared in 2016 and is already supported by several service providers such as AT&T, Verizon, SK Telecom, NTT Communications and China Unicom. In fact, CORD (Central Office Re-architected as a Datacenter) is based on SDN/NFV concept using ONOS SDN Controller to leverage a common hardware and software infrastructure that offers traditional connectivity and cloud services for residential, enterprise and mobile customers (<http://opencord.org/>, 2016).

#### **2.4.2 Migration challenges in metro networks**

The metro network collects all kinds of traffic coming from the access network and forwards it to its destination within the metro or to the core network. Thus, any network technological change in the last-mile and access layer affects the technologies and the architecture of the metro network. Key challenges faced by *SP* in the metro access and metro aggregation layers are: i) supporting for new technologies such as LTE ePC network requirements for converged voice and data on a 4G LTE network including cells higher density, Phase synchronization and X2 interface (subsections 1), ii) Lowering cost for massive deployment and optimization of existing legacy TDM based resources (subsection 2), iii) efficient centralized control for automated and programmable networks (subsection 3) (Huang et al., 2008) and (Choi et al., 2016).



### 2.4.2.1 New ePC network requirements

The backhaul network in the metro access layer collects traffic from the last-mile network elements in the access network and grooms it towards the core. 2G evolved to 3G and 4G (LTE) offering much higher bandwidth to customers. 5G is expected to be ready soon with much higher capacities per user and much higher cell densities (Olwal, Djouani & Kurien, 2016) and (Agyapong, Iwamura, Staehle, Kiess & Benjebbour, 2014). While backbone bandwidth in the core and metro core networks is becoming big enough thanks to DWDM introduction, metro access and metro aggregation networks risk to be a bottleneck of the whole network. *SP* design (presented in Section IV-B) is considering the new mobile backhaul networks and service requirements discussed in (Huang et al., 2009), (Lee et al., 2014), (Agyapong et al., 2014), (Astely et al., 2009) and (Bogineni et al., 2009). The general requirements for mobile backhaul transport networks are summarized as:

- Multiple services access capability (Voice, Data, Video, High Speed Internet (HSI), VPNs, etc)
- Multiple service access Interfaces (TDM, Ethernet, IP interfaces). The trend is moving to All-IP Network, but legacy services still exist.
- Efficient bandwidth utilization.
- Service awareness and Differentiate QoS.
- Carrier class end-to-end OAM toolset.
- Carrier class reliability (less than 50 ms protection switching, 99.999% availability).
- Precise Clock Synchronization: Specially 4G requires phase synchronization in addition to the frequency synchronization.

*LTE cells higher density challenge:* In order to provide higher downlink and uplink rates and to be able to offer required huge bandwidth per user, the mobile cells in the RAN are getting



smaller and smaller. Thus, the coverage of eNodeB is much smaller than 2G/3G towers. 5G mobile technology is also coming with more heterogeneous cellular architecture as well as much higher cell density and traffic constraints (Olwal et al., 2016) and (Astely et al., 2009). This is driving to a huge tower density in smaller areas and thus a more complicated backhaul network in the ePC transport. Replacing existing legacy equipment while satisfying much higher density LTE networks adds more complexity to our backhaul network design (Choi et al., 2016) and (Bogineni et al., 2009).

*LTE Phase synchronization challenge:* Frequency synchronization has been implemented for legacy technologies such as 2G, 3G and LTE-FDD mobile technologies. New backhaul networks need to deal with recent LTE-TDD and LTE-Advanced stringent time and phase synchronization requirements. It is not economically or technically feasible to deploy Global Navigation Satellite System GNSS (such as GPS, GLONASS or Beidou) receivers everywhere in the network because not every location in the network has access to GNSS signals. In some cases, GNSS signals may also face interference issues. New timing protocols as well as good transfer design across the backhaul network have to be addressed in the E2-IOPN migration plan (Murakami et al., 2014), (Golnari et al., 2015) and (Beller et al., 2009).

*LTE X2 interface challenge:* In 4G networks, user traffic is forwarded to the core network through S1 interface going from the eNodeB in the access network up to the ePC in the core. Unlike 2G and 3G, eNodeBs in 4G are also talking among each other using a so-called X2 interface. In order to deal with any-to-any X2 interface traffic between various eNodeBs in the RAN, several MNOs are going for IP based solutions in the metro access as a backhaul solution (e.g. IP/MPLS and seamless MPLS) instead of MPLS-TP in order to offer more flexible service provisioning and more dynamic communication. The challenge faced by *SP* here is the compromise between the cost of massively deploying IP-based backhaul solutions and X2 interface traffic requirements. An optimized design shall consider lower cost technology that would address the requirements of the X2 interface as well. Hand-off traffic to the core routers as well as end-to-end service provisioning, reliability and OAM monitoring are also big challenges. Moreover, MPLS-TP is using the same forwarding plane as IP/MPLS. Thus,

transparent traffic hand-off between MPLS-TP and IP/MPLS domains is a very attractive option for *SP*. The challenge remains in service provisioning mechanisms as well as the hand-off of OAM protocols (Polito et al., 2011) and (Chamania et al., 2009).

#### **2.4.2.2 Legacy TDM based networks challenge**

Although telecommunication market is moving rapidly toward all-IP services and thus Ethernet based transport networks, service providers networks are still having massive deployment of TDM-based components. 2G traffic is still dominating for most MNOs and TDM traffic is still generating important revenue. Thus, TDM-based traffic is not ignored by *SP* migration project. The challenge faced by *SP* is how to deal efficiently with legacy running TDM traffic and transport it in pure packet technologies, without sacrificing its time and bandwidth requirements. Unlike 3G and LTE - which are adopting Fast Ethernet (FE) and Gigabit Ethernet (GE) packet interfaces - 2G is TDM based system and still adopt E1 (PDH) and STM-1 (SDH) interfaces. Today, its rigid pipes make TDM optimized SDH networks no longer efficient for massive Ethernet based transport networks. The migration design from legacy SDH towards MPLS-TP needs to consider a larger and more complex network with complex packet technology, huge bandwidth requirements, and resiliency constraints.

#### **2.4.2.3 Efficient network control challenge**

*SP* is looking for an unified network management system that allows end-to-end visibility on services crossing its network from access to core and beyond (Polito et al., 2011). *SP* long-term vision is considering a centralized service provisioning system that offers fast and dynamic end-to-end service creation and monitoring (Muoz et al., 2012) and (Choi et al., 2016). A big challenge here is how to enhance service provisioning process and, eventually, be able to create end-to-end circuits across different technology domains and using different vendors equipment (Polito et al., 2011).

### 2.4.3 Migration challenges in the core network

Key challenges of the migration faced by *SP* within the core network are: 1) reducing the cost of IP-based networks in order to solve network scalability issue, 2) forwarding deterministic and delay-sensitive traffic in an efficient way, 3) solving the inter-working challenge, 4) monetizing the core transport infrastructure to generate new revenue, 5) deploying a centralized control for automated and programmable networks (Lee et al., 2014).

#### 2.4.3.1 Cost reduction challenge

Network traffic patterns are being more and more deterministic with more latency and performance constraints (Polito et al., 2011) and (Roy et al., 2014). An efficient design shall consider a multi-service packet-based solution with low implementation, expansion and operation (including Power, Space, and Spares) costs to enhance network performance and reduce the high CapEx and OpEx pressure. Although it is a challenging task itself, offloading traffic to most cost-effective layers is inevitable in order to optimize *SP* network long-term TCO (Total Cost of Ownership). The OTN technology is currently the next generation switched transport solution for multi-service E2-IOPN that should address the main core network challenges in a low-cost and efficient way (Gumaste et al., 2013), (Donovan et al., 2008) and (Lee et al., 2014).

#### 2.4.3.2 Efficient traffic forwarding challenge

Re-distributing massively existing traffic, in particular from L3 VPNs, to new layers may require huge traffic engineering and operational effort from *SP*. The key challenge is how to properly re-classify existing traffic based on its characteristics (deterministic traffic pattern (Roy et al., 2014) and (Yin et al., 2012), delay sensitive services, etc) and then map it to the right pipes, either OTN ODUs or IP/MPLS tunnels. Based on the new traffic mapping matrix, *SP* has to make decisions on the new core routers roles and interfaces in the network and where to deploy new OTN switches. Unnecessary aggregation core routers need to be removed and re-assigned to new locations where required. There is a trade-off between expenditures on

new OTN switches and the amount of CapEx saved by avoiding future expansions in IP/MPLS routers. New traffic distribution among core routers and the right non-blocking integrated OTN/DWDM switches needs to be specified. Then, an efficient design need to be developed to optimize power, space and future network expansions (Eramo, Listanti, Sabella & Testa, 2014).

#### **2.4.3.3 Inter-working challenge**

Inter-working OAMP capabilities is a major issue for end-to-end service carrier solutions due to native Ethernet limitations. Effort has been paid by standardization bodies to offer carrier class OAMP tools for new complicated enterprise and data center scenarios (Gumaste et al., 2013). OTN framing was introduced as a solution to incorporate strong OAMP capabilities. Nevertheless, Ethernet and OTN OAMP mechanisms are transparent to each other. Thus, it is still not possible to have end-to-end OAMP correlation across native Ethernet and OTN switched domains (Polito et al., 2011), (Nowell et al., 2009) and (Choi et al., 2016).

#### **2.4.3.4 Resources monetization challenge**

Currently, most of *SP* transport infrastructure in the core network is based on CapEx-consuming dumb pipes used to carry L3 traffic. In addition to the need of reducing the network TCO discussed in previous sub-section, *SP* needs to generate new revenues based on new business models by monetizing all layers of the network. Introduced OTN network needs to move from simple connectivity provider to new revenue generating pool of resources. *SP* vision was to stop putting all traffic on high cost L3 VPNs and start selling capacities on lower layers. The challenge is how to properly define new business models based on monetized optical network resources and attract new customers.

#### **2.4.3.5 Efficient network control challenge**

Service providers are looking for more centralized control, faster and automated end-to-end service level management across reliable multi-vendor networks (Polito et al., 2011) and (Huang et al., 2009). Current fragmented network design with proprietary interfaces and vendor-specific architectures is resulting in many inter-operability challenges. It is more efficient to have an unified multi-domain network control regardless of specific technology or equipment provider (Chun et al., 2014) and (Chamania et al., 2009). Since core routers are relying on heavy dynamic control plane to route traffic from source to destination, monitoring and troubleshooting these routers require skilled human manual intervention (Polito et al., 2011). Thus, current complex networks based on different islands of technologies and vendors need to be migrated to more efficient multi-domain, multi-vendor and multi-layer network that offers faster end-to-end service provisioning and more efficient monitoring (Casellas et al., 2012).

### **2.5 SP migration plan towards E2-IOPN**

In order to address the various challenges discussed in the previous section, we review in this section a transformation plan model from a service provider *SP* empirical perspective.

#### **2.5.1 Towards GPON in access networks**

Several FTTx technologies are competing in the access area such as GPON, 10GE-PON, 40G-PON, WDM-PON as well as point-to-point active Ethernet technologies. Among them, GPON is the dominant technology in the last-mile network due to its low-cost, simple architecture and especially passive components (Splitters) (Maes et al., 2012). Although a transition plan should take advantage of existing infrastructure to build a new one, the migration from legacy copper based platforms towards pure passive optical solutions requires replacement of all legacy components. Unlike green field cases where everything is built from scratch, all DSLAMs in brown field scenarios are replaced by Optical Line Terminations (OLTs) (Effenberger et al., 2007). DSL modems are replaced by Optical Network Terminations (ONTs). Finally, all copper ca-

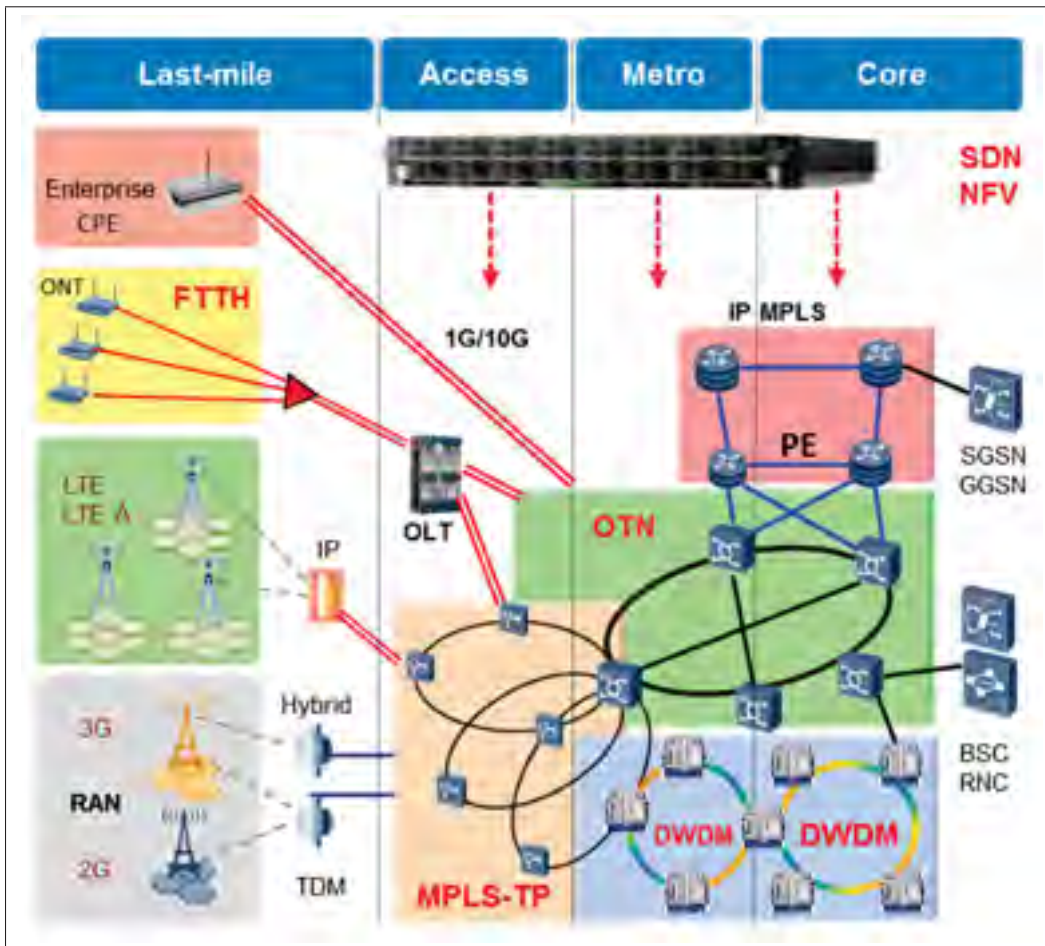

Figure 2.4 Transport Network transformation towards E2IOPN

bles need to be swapped by optical cables up to the end-user premises. Figure 2.2 summarizes legacy architecture of DSL based networks while Figure 2.3 presents proposed FTTH design including OSP components, active elements as well as ACS and OFMS systems.

### 2.5.1.1 General architecture

The general architecture of GPON network is almost similar to the legacy DSL one. Both networks are based on a star topology (Hub-and-Spoke) in which customers are served by several line aggregation equipments installed in *SP* aggregation points (POP). The main difference is that the distance and capacity offered by copper cables is very limited compared to

fiber cables. Thus, DSL customers have to be within a range of hundreds of meters far from the DSLAM. In the more frequent case where customers are far from POP location, smaller Mini-DSLAMs used to be deployed in Fiber-to-the-Curb (FTTC) topology as shown in Figure 2.2. Fiber is reaching and terminated in an active (powered) street cabinet located closer to customer buildings. Copper cables are distributed to each house within a range of 300 m (Effenberger et al., 2007). GPON customers can be within the range of 20 km from OLTs (Dalela et al., 2015). Instead of installing the GPON splitters in the street manholes or handholes, *SP* design is based on passive (no power required) Fiber Distribution Termination (FDT) cabinet. FDTs are installed in proper location covering districts with a radius of 500m from customer buildings (Figure 2.3). FDTs offer easy and flexible access and handling of the splitters and the optical fiber cables. For route diversity, the FDTs shall be connected to POPs with two redundant physical fiber links. Each Customer building gets minimum one fiber connectivity without protection from related FDT. The cable of 96 or 144 fibers feeding the FDT from the POP is called *Feeder cable*. The cables of 24 up to 144 Fibers cable from FDT to distribution point (Joint closure in Mini Manhole) are called *Distribution cables*. Finally, the cables of 2 up to 8 Fibers from the Distribution Point to each building are called *Drop cables*. Maximum two level of splitting is suggested: One at FDT and second in customer building in case of Multi-dwelling unit (MDU) as detailed in Figure 2.3. Although the technology allows splitting ratios of 64 and 128, the recommended splitting ration is 32 in order to offer customers an average bandwidth up to 80 Mb/s (2.4 GB/s shared by 32 customers). Figure 2.3 summarizes general FTTH design including OSP components, active elements as well as ACS and OFMS systems (Kim, Lee & Han, 2010), (Ford et al., 1993), (Ouali, Poon, Lee & Romaiti, 2015), (Zukowski, Payne & Ruffini, 2014) and (Ouali & Poon, 2011).

### **2.5.1.2 Out-Side Plant (OSP)**

*SP* OSP design starts with a complete site survey of the district, collecting data of customers, location of FDTs, trench routes and duct configuration as well as cabling and fiber schematics.



Examples of service providers OSP plans are discussed in (Kim et al., 2010) and (Ford et al., 1993).

**a - Cable route planning:** Several solutions are proposed in order to optimize the cable route length connecting each FDT with full diversity to the nearest CO or POP (Ford et al., 1993) and (Agata et al., 2009). The requirements of each FDT in terms of incoming and outgoing fibers need to be accurately calculated. All *SP* FDT design work has minimum 33% more capacity, than present requirements. Two types of trenching are preferred by *SP*: Mini trenching (9x50cm, 9x45cm or 7x50cm) from FDT to Distribution point and Micro trenching (4x40cm, 3x35cm) from distribution point to customer buildings. Other trenching sizes may be used for more economical solution and availability in different countries. *SP* is using two sizes of HDPE (High-Density Polyethylene Pipe) ducts: HDPE pipe with 32mm OD (Combinations: 12x32mm, 9x32mm, 6x32mm or 3x32mm) from FDT to Distribution point and HDPE pipe with 20mm OD from distribution point to customer buildings. Duct should be encased in concrete for full protection.

**b - Passive FDT configuration:** For an optimized and practical design, each FDT deployed by *SP* offers a maximum capacity of 576 building connectivity. If in any given district, the buildings connectivity requires more than this capacity then a second FDT would be installed to cater the full connectivity with equal distribution. Several variants of FDTs are available in the market with sizes of 20 RU or 30 RU (Rack Unit) for example (1RU = 44mm). Figure 2.5 shows an example of 20U FDT selected by *SP* to cater different combinations of ODFs. The size of each ODF is depending on the offered number of fibers (for instance, 1U ODF for 48F, 2U ODF for 96F and 4U for 144F). In this example, the splitter chassis occupies 5U of the FDT where several splitters with different combinations (2:4, 2:8, 2:32, 2:4+2:8) can be accommodated. FDTs and customer buildings are tagged by Tagging codes. An example of tagging code used by *SP* is highlighted in Figure 2.6 showing the city, district and street names as well as the building and unit numbers.



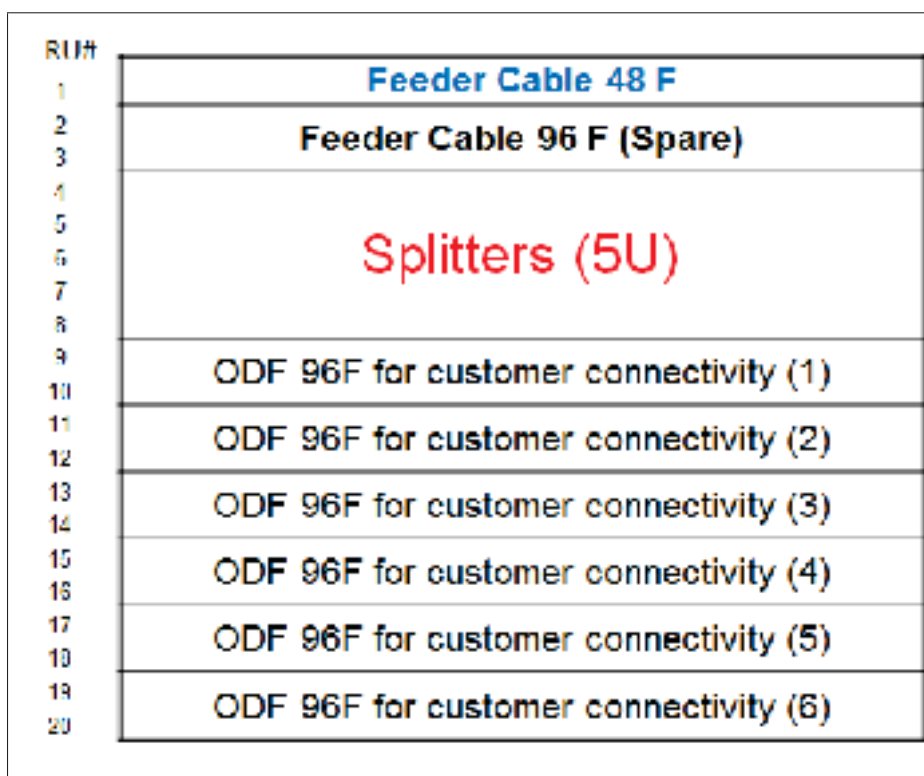

Figure 2.5 Example of *SP* passive FDT configuration

**c - Splitter distribution:** Splitters of different types and combinations can be installed in various locations depending on customer distributions and building types. The different scenarios of splitting used by *SP* are summarized as follows:

- Inside the Fiber Distribution Termination Cabinet (FDT): different splitter types and combinations (2:4, 2:8 or 2:32) can be used. In fact, 2:4 and 2:8 splitters are installed inside the FDT in case of multi-stage splitting where a first stage splitting is done in the FDT and a second one in the MDU (inside the multi-units building) as shown in Figure 2.5. The total splitting ratio including both splitters (in FDT and in MDU) depends on the bandwidth requirements of the customers. Although it can be 32, 64 or even 128, *SP* recommends not to exceed a total splitting ratio of 32 so an average of 80 Mbps can be offered for each customer (2.5 Gbps divided by 32).

- Inside the Multi Dwelling Unit (MDU) at suitable locations inside customer building: The MDU is used in case of multi-stage splitting. Inside the MDU, a 4 ports (1:4), 8 ports (1:8), 16 ports (1:16 or 2 x 1:8) splitter is used with no drop cable protection.
- Single Dwelling Unit (SDU) with only 2-ports: ODBs with no splitter is installed in single customer building. It is installed with the boundary wall with outdoor specifications at minimum 2.0m height.
- Direct point-to-point Active Ethernet customers (discussed in previous section): A dedicated fiber is offered without crossing any splitters neither in FDT nor in ODB. Only for fiber management and monitoring reasons, the fiber is crossing the FDT using the spare feeder ODF (96 F) shown in Figure 2.5.

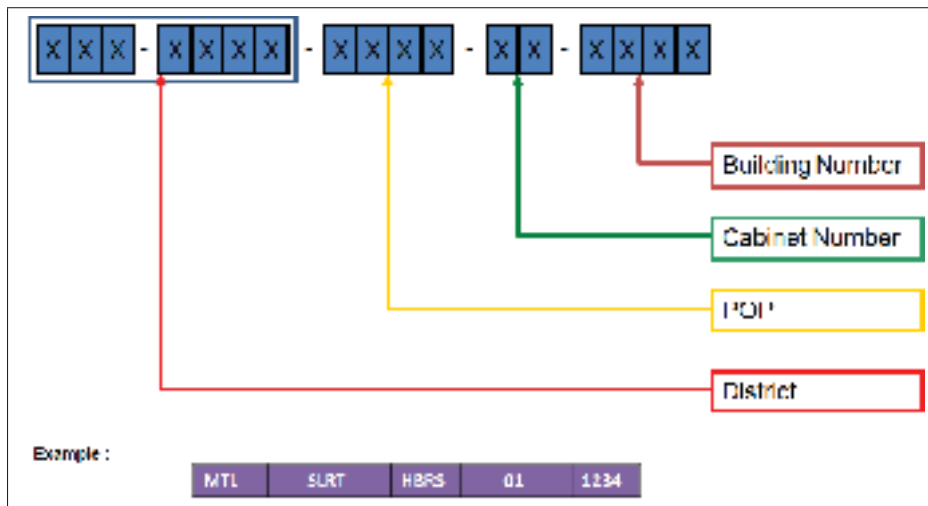

Figure 2.6 Example of Tagging code of FDTs and Customer Buildings

### 2.5.1.3 Auto Configuration Server (ACS)

Due to the high FTTH customer activation rates, the deployment of an Auto Configuration Server (ACS) is becoming crucial for *SP*. This new component is using a L3 protocol called TR-069 which offers *SP* customer care teams the ability of remote CPE management, automatic configuration and dynamic service provisioning (Figure 2.3). Several functionalities are

offered to manage one or a set of CPEs at the same time (by OLT, by District, by Group, by VLAN...) (Stusek et al, 2016) and (Rachidi & Karmouch, 2011). *SP* design was based on redundant ACS and DHCP servers where the main and backup servers are dual-homed to two PE routers. The system resiliency is achieved via VPLS multi-homing feature. New Management VLAN  $VLAN\ x$ ,  $x \in A$  ( $A$  a dedicated range of IP Addresses), for instance, has to be set for every ONT.

#### Algorithm 2.1 Automatic ONT remote activation

```

1 Input: Total number  $N$  of ONTs
2 Output: Automatic remote activation of the  $N$  ONTs
3 for all  $i = 1 .. N$  do
4   if ONT  $i$  is connected by the subscriber to the fiber link then
5     I - ONT  $i$  detects the signal and communicates automatically with the DHCP
       server using:
       1.  $VLAN\ x$ : already pre-configured in ONT  $i$  and the DHCP server
       2.  $MAC\ i$ : the MAC address of ONT  $i$ 
       II - DHCP server provides necessary information to ONT  $i$ . Thus, ONT  $i \leftarrow$ :
       1.  $IP\ i$ : new assigned IP address for ONT  $i$ 
       2. ACS server IP address (gateway IP address)
       3. DNS IP address (same as ACS server if ACS server acts also as DNS server)
       III - ONT  $i$  communicates with the ACS server (acting as DNS server) to
         receive ACS URL (resolved IP address) through "DHCP option 43" protocol
       IV - ONT  $i$  initiates the CWMP session with ACS server and wait for the
         response from the server to confirm the establishment of the session
       V - Once the session is activated, TR-069 messages are bridged transparently
         by the OLT and forwarded to ONT  $i$  for remote management and monitoring
6   end
7 end

```

For more scalability, several regions are defined and served by several VPLS domains to provide connectivity between ONTs to the ACS and DHCP servers in a hub and spoke topology.

Each VPLS instance is configured with the logical interface of the attached OLT *VLAN*  $x$  that is to be cross-connected to the DHCP and ACS server. A second *VLAN*  $y$ ,  $y \in A$  shall be created for synchronization between redundant ACS servers through L2VPN connectivity (Stusek et al., 2016) and (Savić, Papp, Rešetar, Majstorović & Spasojević, 2013). The connectivity between all FTTH subscribers' ONTs and ACS servers as well as the communication with the DHCP server for IP assignment process have to be properly designed and implemented. The algorithm 2.1 presents the automated ONT remote activation process deployed by *SP* to remotely activate and manage the millions of new GPON customers recently connected to the network in a real-time manner.

#### **2.5.1.4 Optical Fiber Monitoring System (OFMS)**

Due to increasing FTTH customers and high risk of fiber cuts in the last-mile, a new component called Optical Fiber Monitoring System (OFMS) was deployed by *SP* to monitor his FTTH OSP networks. A further example of an other service provider design using OTDR solution to monitor FTTH fiber cables is discussed in (Dalela et al., 2015). Further to monitoring point-to-point fiber connectivities in metro and core using classic OTDR solutions, OFMS is a recent OTDR based solution offering fiber plant monitoring for point-to-multi-points FTTH networks as well. In fact, the OFMS solution deployed by *SP* is based on new introduced components in the FTTH network that can be summarized as follows:

1. An ultra-high resolution OTDR and scalable optical switches are installed at the OLT side in the POPs. They periodically inject a separate frequency (1650nm) in-line with the traffic.
2. Special reflectors are installed in residential and businesses CPE connectors. Reflector component should have Low insertion loss (about 0.5dB) and reflectance (about -30dB) at traffic wavelength (1490nm) and high reflectance (about -7dB) at test wavelength (1650nm). It should be easily inserted in ONT using SC/APC Female connector (Agarwal & Hutcheson, 1995).

3. The OFMS management system analyzes the reflected back-scatter signal and traces peaks reflected by each ONT reflector. Received signal is then plotted into a back-scatter X/Y display in dB vs. distance graph.

Event analysis is performed in order to populate the table of results. OTDR measures event loss expressed in dB (the difference in optical power level before and after an event). Received power peak levels should be, in general, in the range of 4-5 dB. In case the peak of an *ONT i* is missing (e.g. power level less than 1 dB) as shown in Figure 2.7, then *SP* NOC technician concludes on the affected fiber. The distance from the OLT to the failure is estimated allowing proactive maintenance and saving skilled technicians dispatches (Dalela et al., 2015).

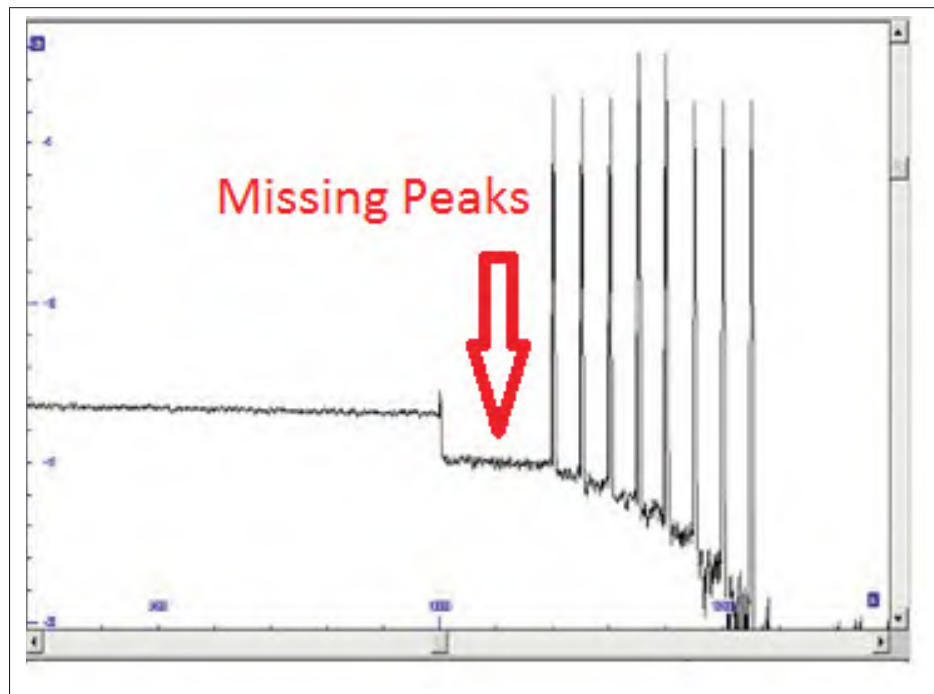

Figure 2.7 Example of missing reflection peaks in OFMS system

For precise localization on OFMS GUI, integration with Geographical Information System (GIS) databases with accurate network and fiber distribution maps is a must. Fiber foil lengths inside street man-holes and hand-holes (for instance, 30 m in the case of *SP*) has to be set

accurately within the database in order to locate the fault within up to +/- 3m accuracy. This would provide enough information about the health of each last-mile fiber cable.

## **2.5.2 Towards MPLS-TP in Metro Networks**

In this section, we review *SP* network transformation as-built design from his pure legacy SDH based networks toward MPLS-TP solution. This High-Level Design (HLD) can be implemented as a proven backhaul solution to connect various access POPs to the core transport network. Legacy TDM based services and new timing and QoS requirements are considered in MPLS-TP based network design (Huang et al., 2008), (Golnari et al., 2015) and (Choi et al., 2010).

### **2.5.2.1 General architecture**

The MPLS-TP network design is in general using the same ring-based architecture already preferred in legacy SDH access and metro networks. Different ring-based protection mechanisms offer high network resiliency. Figure 2.8 presents *SP* deployed MPLS-TP ring model based on several research analysis and service providers best practice. It includes traffic forwarding main and protection paths, OAM signaling and timing messages as well as hand-off to the core network. *SP* ultimate target is to slowly replace existing SDH network elements by new MPLS-TP based equipment (Choi et al., 2016). While keeping using the same existing fiber cables infrastructure, remote access SDH devices are slowly replaced by new MPLS-TP ones and the CO SDH aggregator is replaced by an MPLS-TP based one. Thus, *SP* gradually migrates from pure TDM to pure packet world. In legacy SDH, traffic was mapped in fixed size virtual containers from low bit-rate containers (VC-11 and VC-12) up to higher bit-rate containers (e.g. VC-4). Low order virtual containers were then groomed into higher order containers and switched by TDM based switching fabrics up to destination.

Nevertheless, service providers with massive TDM-based deployments are not always able to afford high CapEx to replace all TDM networks at once. In order to help these service





gation equipment in the POP), need to replace existing SDH equipments. Using same existing fiber cables, new MPLS-TP access devices are connected in a ring to the new MPLS-TP aggregator in the POP. These access devices collect traffic coming from the access (e.g, from the RAN), map it in dedicated PWs following proper classification and prioritization, groom the PWs in protected LSPs and forward it to the POP. A set of layer 2 VPNs are formed between the MPLS-TP access devices and the aggregators. Unlike SDH containers, the size of MPLS-TP tunnels is configured based on different parameters (Committed Interface Rate CIR, Peak Interface Rate PIR, QoS and VLAN priorities) (Malis et al., 2012).

### 2.5.2.2 LTE X2 Traffic Engineering

In general, 2G/3G and 4G towers in the RAN are communicating to the core network on a hub-and-spoke (point-to-multi-point) architecture using different kind of interfaces. To address LTE X2 interface challenge highlighted in Section 3-B, *SP* technical team analyzed the compromise between using high-cost and more flexible IP-based solutions in the backhaul versus opting for an efficient cost-effective design that would fairly address the requirements of X2 traffic. In fact, although data carried by X2 interface is expected to grow with coming advanced radio coordination techniques in 5G higher cell density deployments, current statistics show that S1 interface occupies 97% of LTE traffic while X2 interface consumes only 3% of that bandwidth. In *SP* design, X2 interface traffic is simply forwarded in higher priority pipes and looped back in the first PE router in the boundary between metro and core networks (PE router A and B in Figure 2.8). This design avoids going for costly IP-based technologies and more complicated configurations in the access and metro layer (Bogineni et al., 2009). We emphasize that low-cost MPLS-TP based ring remains more efficient solution for both S1 interface point-to-multi-point (Roy et al., 2014) and any-to-any X2 interfaces traffic patterns. A detailed cost comparative study done by *SP* validating this choice is presented in Section VI. In the POP, MPLS-TP aggregators are connected directly to the core network through IP/MPLS routers if L3 VPN is required (e.g. as the case of X2 interface). In some use cases where connection-oriented circuits are enough to forward traffic to determinate destinations with no



need of routing functionalities (e.g., enterprise VPNs, FTTx OLTs and mobile backhaul use cases, etc.), a much lower cost alternative is to use OTN switches to forward traffic to the core network instead of IP routers (Sommer et al., 2010), (Murakami et al., 2014), (Malis et al., 2012) and (Beller et al., 2009).

### 2.5.2.3 OAM plan

Table 2.1 SP activated OAM tools in the metro networks

<b>Fault Monitoring (FM)</b>	<b>Performance Monitoring (PM)</b>
Continuity Check (CC)	Delay measurements (DM)
Connectivity Verification (CV)	Delay Variation measurements (DVM)
Link trace (LT)	Loss measurements (LM)
Ping Test (in BFD)	Throughput measurements (TM)
Remote Defect Indication (RDI)	
Throughput measurements (TM)	
Alarm Indication Signal (AIS)	
Loopback (LB)	
Lock Report (LKR)	

Although MPLS-TP technology is targeting the total swap of SDH, MPLS-TP inherits strong OAMP tool-sets from his precedent technology. OAM messages were carried in various SDH frame overhead bytes (RSOH + MSOH) while in MPLS-TP, they are forwarded in-band within MPLS-TP Generic Associated Channel (GACH) in parallel with end user traffic (Kim, Ryoo, Kim & Lee, 2014). As highlighted in (Gumaste et al., 2013), there is a lack of strong directions from standards driving vendors and service providers implementations. In fact, two kinds of OAM tool-sets variants are currently used by MPLS-TP equipment manufacturers, a) GACH + Y.1731 (ITU) and b) BFD/LSP with Ping Extension option (IEEE). While GACH + Y.1731 tool-set has better fault detection function, it is limited to L2 and below. BFD supports fault detection up to L3 (Nowell et al., 2009) and (Murakami et al., 2014). Since MPLS-TP is based on the same forwarding plane construct as IP/MPLS (using LSPs and PWs), end-to-end service provisioning as well as enhanced OAM monitoring across both MPLS-TP and IP/MPLS domains is a big motivation for several service providers including *SP* (Polito et al., 2011).

IP/MPLS is relying on dynamic control plane to set tunnels and OAM message using BFD variant. The ultimate plan for *SP* is to integrate MPLS-TP and IP/MPLS domains using BFD-based OAM tools instead of GACH + Y.1731 in order to maintain the OAM messages synergy. Table 2.1 summarizes the minimum Fault Monitoring (FM) and Performance Monitoring (PM) OAM tools enabled in *SP* network for LSPs and PWs to improve the network performance and better match user experience requirements (Polito et al., 2011) and (Murakami et al., 2014). Service providers shall make sure (during bidding phase) that these OAM mechanisms are hardware coded (on FPGA) to provide much faster and more efficient service monitoring (this is not always offered by every vendor equipment on the market). Particularly, PW/LSP 1:1 APS shall be used in order to benefit from fast switching less than 50 ms. For unidirectional Continuity Check (CC) OAM tool, Echo packets check period (CV interval) shall be set to 3.3 ms in order to make detection of failure within less than 10 ms (some equipment have longer default values).

#### 2.5.2.4 Network resiliency plan

Transport networks are built to have maximum resiliency to eventual failures or link cuts (Kim et al., 2014). MPLS-TP as a carrier grade transport technology is offering SDH-like less than 50 ms protection mechanisms (Huang et al., 2009), (Murakami et al., 2014) and (Kim et al., 2014). As shown in Figure 2.4 and Figure 2.8, the links to the UNI end-user Ethernet port are provisioned using Link Aggregation (LAG) protection mechanism based on Link Aggregation Control Protocol (LACP) (Sommer, et al., 2015). LAG offers *SP* a low-cost traffic protection as well as an efficient load balancing mechanism. In case of eventual port or link failure, traffic switches to backup link using second UNI port. Inside the MPLS-TP ring, 1+1 protected LSPs (active and standby LSPs) are assigned to each access node  $A_i$  with required bandwidth  $B_j$ . The LSPs are forwarded to MPLS-TP aggregators in the POP. Ingress services  $S_{ij}$  (mobile or enterprise traffic) for a type of service  $j$  received by access node  $A_i$  is mapped in dedicated and protected 1:1 PW ( $P_{ij}$ ) with differentiate QoS ( $Q_{ij}$ ) and Bandwidth ( $B_{ij}$ ).

Although it may add more costs, *SP* design requires full MPLS-TP aggregators redundancy by configuring them in Dual-Node Interconnection (DNI) mode to avoid single point of failure. All MPLS-TP rings coming from access side are terminated at both aggregators as shown in Figure 2.8. Interfaces between MPLS-TP and the core domains are also protected. Interfacing OTN switches needs also to be configured as DNI as shown in Figure 2.4. LAG is used again between MPLS-TP aggregator A towards OTN switch A and between MPLS-TP aggregator B towards OTN switch B. MPLS-TP LSPs are terminated in MPLS-TP aggregators and forwarded to the PE router as pure 10 GE or 40 GE Ethernet interfaces. In few cases where the PE router is not co-located with the MPLS-TP aggregators in the POP, the LSPs are wrapped in protected ODUs and forwarded by OTN switches up to the PE routers as shown in Figure 2.8. This design is still valid in case of intermediate *Hybrid Solution* phase where SDH stacked rings are also terminated in the universal switch boards of the aggregators (Zhu et al., 2012). In the later scenario, TDM and packet traffic travel in totally separated rings up to the aggregators. TDM traffic is either dropped locally by the aggregators using TDM client interfaces or forwarded to local OTN switch for further transmission.

For further resiliency on the boundary between the metro and core networks, Virtual Router Resilient Protocol (VRRP) is configured by *SP* between the two PE routers. As depicted in Figure 2.8, the PE routers communicate via L3 VRRP heartbeat messages forwarded transparently through the two MPLS-TP aggregators in DNI mode. This design protects *SP* network from any failure in MPLS-TP aggregators, OTN switches, PE routers or any links between them. Equation (1) explains that a proper traffic engineering guarantees the total aggregation bandwidth coming from all access Equipment ( $e = 1 \dots E$ ) within access Rings ( $r = 1 \dots R$ ) does not exceed a defined margin percentage from the sum of physical aggregated link capacities towards the OTN switch or PE router. Otherwise, the number of links towards the core shall be expanded.

$$\sum_{r=1}^R \sum_{e=1}^E B_{re} \leq e * C_{core} \quad (1)$$

$C_{core}$  is the sum of physical aggregated link capacities towards the core network and  $e$  is a margin threshold percentage to control the aggregated bandwidth before going for expansions. For instance,  $e$  is set to 80 percent in case of *SP*.

### 2.5.2.5 QoS plan

Received packets from the end-users meet different types of characteristics and shall be identified and classified according to several rules (Cao et al., 2010). Detailed discussion about the functionalities of the QoS process is provided by (Choi et al., 2010) and (MEF Forum, 2012). These functionalities can be summarized as Classification, Pre-Coloring and Policing, Coloring and Marking then Queuing and Congestion Control (Addeo, Cazzaniga, Crescentini & Valente, 2010).

**Classification:** Flow classification is done either using simple methods such as translations from different Class of Service (CoS) identifiers to Per-Hop Behaviors (PHB) levels (e.g. BE, AF, EF and CS) (Cao et al., 2010) or through more complex flow classification techniques such as Access Control Lists (ACL), MAC address, source and destination IP addresses, TCP/UDP port number, protocol type. CoS identifiers can be *layer 2* VLAN Priority Code Point PCP (IEEE 802.1P), *layer 2.5* MPLS EXP and *layer 3* IP Differentiated Services Code Point DSCP (RFC2474). In order to enhance customer experience, *SP* builds a consistent design targeting an end-to-end service aware QoS schemes matching performance requirements of various services at the same time and crossing different domains of the network (Polito et al., 2011). While it is technically possible to use eight or more class of services, (De La Houssaye & Bernardo, 2012) and (MEF Forum, 2012) recommend optimizing the number of classes and classifying traffic into *only four levels of classes* with an unified scheme across the entire network. This approach was adopted by *SP* in order to simplify the implementation of the end-to-end QoS treatment and make inter-working between MPLS-TP and IP/MPLS domains much easier.

**Pre-coloring and policing:** The second step in the QoS process is the assignment of Committed Access Rate (CAR) for each class of service in which dedicated bandwidth is allocated by

Table 2.2 SP QoS Scheme in the metro network

CoS	PCP	Color	CAR	Queuing
Very High (H+)	7	6	$CIR_{H+} = PIR_{H+} = \alpha * BW_k$	PQ
High (H)	5	4	$CIR_H = PIR_H = \beta * BW_k$	PQ
Medium (M)	3	2	$CIR_M = PIR_M = \gamma * BW_k$	WRR or WFQ
Low (L)	1	0	$CIR_L = 0, PIR_L = BW_{Max}$	WRR or WFQ

defining related CIR and PIR parameters. The following four levels classification is adopted by *SP* for different types of services:

- Very High (H+) class of services for OAM and Signaling, IEEE 1588 Synchronization, 4G IP control (DHCP), S1 and X2 signaling, etc.
- High (H) class of services for Signaling, Voice (RTP), Real Time Gaming, Video (Live Streaming), etc.
- Medium (M) class of services for Video (Buffered Streaming), TCP-based (e.g., www, e-mail, chat, ftp, p2p), etc.
- Low (L) class of services for Data (2G GPRS, 3G HSPA, 4G Data), etc.

Using 3 bits in the packet headers, both CoS identifiers (Ethernet *PCP* p-bits and MPLS/MPLS-TP *DCSP EXP* bits) offer 8 classification levels. MPLS-TP based backhaul network in the metro or metro access is interfacing the enterprise customers and the RAN network through native Ethernet interfaces. Thus, Ethernet *PCP* is used by *SP* to identify each incoming service class from the access network. The same value (0 to 7) is copied between *PCP* p-bits and *DCSP EXP* bits to match priority levels between Ethernet and MPLS or MPLS-TP identifiers. This plan makes better synergy between domains' owners (Mobile, Transmission and Data domains) and accelerate the service provisioning process (Polito et al., 2011). It offers a *unified QoS mechanism* within whole network domains that may be controlled end-to-end by a centralized application over an SDN controller. Table 2.2 summarizes the QoS model used by *SP* for *PCP* and *Color* assignment for different kinds of CoS.  $\alpha$ ,  $\beta$  and  $\gamma$  represent various percentage

values from the total BW assigned to  $A_k$  satisfying the Equation (2.1):

$$\alpha + \beta + \gamma \leq 1 \quad (2.1)$$

**Coloring or Marking:** In order to be able to detect when traffic flow is exceeding related PIR, *Traffic Marking (or Coloring)* and *Traffic shaping* is used to define threshold restrictions for bandwidth (or burst size) for each service. Service *Color* has to be transmitted across different network domains so that all network elements of the network know exactly which traffic is marked to be dropped first in case of network congestion. In *SP* design, *PCP* p-bits in the Customer VLAN ID (CVID or CVLAN ID) is used to transfer *Color* information between MPLS-TP access nodes and enterprise or mobile RAN networks for same reasons mentioned above (Sommer et al., 2010). When flow rate exceeds PIR, the value of *PCP* changes as per Table 2.2. For traffic forwarded from MPLS-TP aggregators directly towards IP/MPLS routers, LSPs are forwarded to IP/MPLS network or terminated in MPLS-TP aggregators. If terminated, all traffic is groomed in one Q-in-Q Ethernet frame (IEEE 802.1Q-in-Q) interface and forwarded to the core router. *Color* information is transferred through Drop Eligible Indicator bit (*DEI-bit*) in Service VLAN ID (SVID or S-VLAN) which has only two priority levels (0 or 1) (Sommer et al., 2010). The use of the *DEI-bit* identifies the packets eligible to be dropped in case of network congestion.

**Queuing and Congestion Control:** The final step in the QoS process is the *Queuing and Congestion Control*. In fact, packets are mapped into dedicated PWs based on CoS and required CIR. Without queuing, all *SP* traffic is treated in the same way and queued as First-In First-Out (FIFO) principle with no priority or flow classification. It is important to have higher priority (*H* and *H+*) traffic set as Priority Queuing (PQ) and forwarded first. This traffic is, in general, sensitive to delay and jitters and does not tolerate packets loss. Medium (*M*) priority traffic is set as Weighted Robin Round (WRR) or Weighted Fair Queuing (WFQ) where traffic flow is weighted based on assigned priorities (Cao et al., 2010). Lowest class (*L*) is a best-effort class

and is eligible to be dropped in case of eventual network congestion ( $CIR = 0$ ). Nevertheless, putting PIR equal to maximum available bandwidth offers  $L$  class traffic the advantage of using the whole bandwidth whenever there is no competing traffic from higher-level classes (Cao et al., 2010).

### 2.5.2.6 End-to-end service provisioning

All traffic flows from last-mile are received, classified and groomed by MPLS-TP access nodes before being forwarded to the core network. In  $SP$  service provisioning process, 1+1 protected LSPs are provisioned statically from each access node to the MPLS-TP aggregators in the POP. Assume  $i$  represents a specific service (mobile, enterprise, OAM and signaling, timing traffic...),  $j$  represents a mobile tower in the RAN (BTS, NodeB or eNodeB) or a certain enterprise, and  $k$  represents an access node or a customer site. Table 2.3 summarizes the parameters and constraints used by  $SP$  end-to-end service provisioning process in order to limit traffic congestion within the MPLS-TP rings. In fact, a dedicated  $LSP_k$  protected by  $LSP_{pk}$  is carrying traffic coming from each access node  $A_k$ . A service  $i$  received by access node  $A_k$  from tower or enterprise  $j$  is distinguished in each egress interface either by i) Q-in-Q VLAN IDs (CVLAN + SVLAN) or ii) CVLAN + a P-bit identifier. In both cases, its bandwidth requirements are represented in Table 2.3 as  $BW_{ijk}$  and are mapped in an elastic PseudoWire PW ( $PW_{ijk}$ ).  $PW_{ijk}$  and its protection  $PW_{pijk}$  are respectively forwarded to the aggregator inside  $LSP_k$  and its protection  $LSP_{pk}$ . In-band OAM and precise clock PTP-1588-V2 messages are also forwarded in-band (in parallel) with customers traffic in dedicated PWs.

Arriving to the POP or CO, the LSPs are in general terminated in the MPLS-TP aggregators. The PWs carrying deterministic traffic with known destinations are forwarded to OTN switches and mapped to dedicate ODUs. Remaining PWs are mapped to one common SVID  $S_k$  for each access node  $A_k$  before handing over to IP/MPLS core routers. The bandwidth ( $N \times 10$  Gbps or 40 Gbps) between MPLS-TP aggregators and PE routers needs to be well planned as shown in Equation (1) to avoid traffic congestion and best-effort traffic drop.  $N$  can increase gradually as traffic coming from access network is increasing or if enterprise traffic shares



MPLS-TP ring bandwidth. Each  $LSP_k$  has its own CIR ( $CIR_k$ ) and PIR ( $PIR_k$ ) parameters. Also, protection  $LSP_{pk}$  has its own CIR ( $CIR_{pk}$ ) and PIR ( $PIR_{pk}$ ) parameters which are in general equal to  $CIR_k$  and  $PIR_k$ . Total bandwidth required by all protected  $LSP_k$  and  $LSP_{pk}$  shall not exceed the capacity of MPLS-TP ring capacity called  $BW_{Max}$  in Table 2.3. This concept offers  $SP$  a bandwidth-on-demand mechanism that saves huge amount of unnecessary wasted capacities (Zhang, et al., 2015). If the total capacity required by all  $PW_{ijk}$  of an access node  $A_k$  is exceeding the capacity assigned to its corresponding  $LSP_k$ , then the access node  $A_k$  starts dropping traffic from the best-effort class  $L$ . Also, in the case where the total capacity required by all " $LSP_k$  forwarded to the core routers is exceeding the capacity of links between the MPLS-TP aggregators and the OTN switches or PE Routers, then the MPLS-TP aggregator starts dropping traffic from the best-effort class  $L$  received from the MPLS-TP rings. In order to make this end-to-end service parameters computed in a centralized way,  $SP$  long-term strategy is emphasizing on the use of SDN and NFV concept to control the network.

If Enterprise client or RAN station bandwidth requirements is reaching or exceeding 1 Gbps,  $SP$  decided to deploy OTN small access devices closer to customers in parallel or as an alternative to MPLS-TP. Extremely delay-sensitive applications like Data Center Inter-connectivity (DCI) and Disaster Recovery (DR) solutions are very common examples due to very low latency offered by OTN. The OTN access node provides the customers interfaces of 1 GE, 10 GE or ODU2e on the UNI side. They are wrapped in dedicated ODU-0 (for 1 Gbps), ODU-1 (for 2.5 Gbps) and ODU-2 (for 10 Gbps) on the NNI (Network Node Interface) side toward the core network. A combination of OTN containers on top of cheaper Coarse Wavelength Division Multiplexing (CWDM) wavelengths is also offered as an efficient and low-cost alternative solution for access rings. Enterprise customers requesting their own dedicated infrastructure for more security issues can be served either by using direct Point-to-point Active Ethernet or by dedicated sub-wavelength connectivity (Polito et al., 2011) and (Veisllari et al., 2015). Two physical links are offered to the end-user using LAG protection mechanism for enhanced resiliency (2.4).



Table 2.3 SP Traffic Engineering model in the metro network

<b>Resources Definition</b>	<b>Traffic from Access</b>	<b>MPLS-TP tunnels</b>	<b>MPLS-TP services</b>	<b>Handoff to Core</b>
Tunnels (VLANs, LSP, PW)	$CVID_k$ $SVID_{ijk}$	$LSP_k(1+1)$	$PW_{ijk}$ (1+1 or 1:1)	$LSP_{Agg}$ or $SVID_{Agg}$
Tunnels Capacity (CIR, PIR)	$BW_{ijk}$ (input)	$CIR_k$ $PIR_k$	$CIR_{ijk}$ $PIR_{ijk}$	$CIR_{Agg}$ $PIR_{Agg}$
Capacity Constraints	$BW_{ijk}$ (input)	$\Sigma PIR_k \leq BW_{Max}$	$\Sigma PIR_{ijk} \leq PIR_k$	$\Sigma PIR_k \leq BW_{Agg}$

### 2.5.2.7 SP network synchronization plan

Timing and synchronization are critical for good operations of telecommunication networks. Legacy TDM networks used to get 2 Mhz or 2 Mbps clock from Synchronization Supply Units (SSU) - if locally available - or extract it from received SDH traffic. Packet networks are using SyncE protocol which provides frequency reference support with high performance. Recent LTE-TDD and LTE-A networks require highest level of accurate synchronization for frequency (16 ppb), phase (up to  $+/- 1.5\text{microsecond}$ ) and Time-of-the-day (ToD). Only PTP IEEE 1588 v2 is the latest technology matching frequency, phase and ToD timing requirements for recent packet networks (Murakami et al., 2014), (Golnari et al., 2015) and (Vallat & Schneuwly, 2007).

For greenfield networks, *SP* plan is based on straightforward deployment of PTP with *full on-path support* by providing a *boundary clock* function embedded in every network element in the path between PTP Grand-master and its PTP clients. The boundary clocks function as a PTP client in upstream direction and as a Grand-master to other boundary clocks and clients in downstream direction. They compensate delays in different network elements (switches, routers, etc.), refresh PTP packets and thus, maintain good precision and accuracy. *SP* makes sure all new switches and routers support boundary clocks (as well as SyncE). In more common non-greenfield scenarios, *SP* uses PTP with *partial on-path support* by deploying *edge Grand-masters* with advanced boundary clocks at selected locations. Being closer to the clients, the edge Grand-masters ensure high accuracy as well as higher network availability and perfor-

mance. This approach offers also more flexibility to *SP* designers to leverage existing infrastructure and avoid upgrading network elements to support embedded Boundary clocks or SyncE (Meier & Weibel, 2007) and (Jasperneite, Shehab & Weber, 2004).

*SP* has also to take into account massively deployed legacy technologies in the network. TDM-based networks require only frequency synchronization using 2 MHz or 2 Mbps as clock reference. These clock signals required by the last-mile equipments (e.g. BTS) have to be translated into information that can be transmitted over the packet networks (e.g. MPLS-TP). Combination of PTP 1588 v2, Synchronous Ethernet (SyncE) or PWE3 with Adaptive Clock Recovery (ACR) for regeneration of 2 MHz (or 2 Mbps) provides several solutions for 2 MHz timing transfer. Unlike PWE3 with ACR function which can be vendor specific, PTP 1588 v2 and SyncE technologies are based on mature standards. SyncE would be used to transmit only frequency (on layer 1) and SSM (Synchronization Status Message) information (on layer 2) to MPLS-TP access nodes (BTS side). The PWE3 function on MPLS-TP access nodes recovers the 2 MHz clock out from SyncE clock and transmits it together with SSM information to the BTS. A limitation here is that the usage of SyncE requires that all switches and routers on the SyncE connection support SyncE mechanism. If only one equipment on the path does not support SyncE, synchronization is broken.

In case SyncE is not supported by all *SP* equipments, it is again possible to use only PTP 1588 v2 for the regeneration of the 2 MHz. An embedded PTP client in MPLS-TP access node (or an external PTP client) generates the 2 MHz needed by PWE3 function of that access node. In MPLS-TP based ring, each access node receives two PTP IEEE 1588 signals from separate directions and switch to the best one as input. For this scenario, *SP* uses the same Primary Reference Clock (PRC) as input for both PTP 1588 v2 Grand-Master as well as for the SSUs that generate the 2 MHz clocks. A Secondary Reference Clock (SRC) is deployed as redundant input in case of PRC failure. Also, second PTP 1588 v2 Grand-master is installed for more redundancy. The fact of having both; PTP 1588 v2 Grand-masters and 2 MHz SSUs; synchronized by the same source (i.e. the PRC) would reduce slip ratio between two the

different clock inputs and enhance accuracy of the transferred clock signals (Chin & Chen, 2009).

### 2.5.3 Towards OTN and EON in Core Networks

Several directions were considered by *SP* in order to address the various faced challenges during the migration towards OTN in the core networks:

#### 2.5.3.1 Multi-Layer Optimization (MLO)

In order to plan an optimized network and reduce the costs, *SP* strategy is based on considering all network layers at once. Each specific traffic has to be forwarded on its most efficient network layer (Castro, et al., 2014) and (Yin et al., 2012). We emphasize on Multi-Layer Optimization (MLO) concept. Figure 2.9 highlights MLO steps in which data shall always be forwarded through the lower layers of the network when possible. *SP* redesigned the whole network by avoiding going up to upper network layers unless it is absolutely necessary (Chun et al., 2014) and (Lee et al., 2010). Connection-oriented traffic with large granularity has to go through layer 0 DWDM, layer 1 OTN or layer 2 MPLS-TP unless routing on L3 IP/MPLS domain is unavoidable (Thyagaturu et al., 2016) and (Gumaste et al., 2013). Statistics shows that 70+% of the transit traffic can be offloaded from IP/MPLS routing layer to OTN switching layer or even DWDM wavelengths. This traffic re-distribution reduces TCO, improves performance and increases reliability (Bertolini et al., 2012), (Eramo, Listanti, Sabella & Testa, 2012) and (Bertolini, Rocher, Bisson, Pecci & Bellotti, 2012). Furthermore, by using universal switching mechanism (Zhu et al., 2012) and ODU-Flex tunnels (Mathew et al., 2015) and (Rambach et al., 2013), MLO based design gets rid of unnecessary aggregation layers and creates direct paths with best bandwidth utilization, allowing, thus, significant savings on future network expansion costs (Rambach et al., 2013) and (Castro et al., 2014).

Practically, a mixture of ODU-k ( $k = 0..5$ ) and ODU-flex pipes on OTN layer traveling over DWDM channels provides optimized pipes with flexible capacities from 1 Gbps to 400 Gbps

(Rambach et al., 2013) and (Yin et al., 2012). Although ODU-5 is standard but currently not really used in service provider networks, it would be more useful when 1+ Tbps DWDM channels will be mature and widely deployed (Trowbridge, 2015) and (Miyamoto, Sano & Kobayashi, 2012). Proper 100 Gbps DWDM wavelength assignment and ODU switching create end-to-end deterministic connections for high granularity traffic. Deterministic traffic would only transit lower layers optical ROADMs and electrical OTN switches up to destination. Backhaul connectivities collecting traffic from OLTs, enterprise or interconnecting data centers within metro network or crossing the core network shall be provided directly through dedicated 40 Gbps or 100 Gbps wavelengths or sub-wavelengths traveling on pure wavelength-switched network up to destination (Thyagaturu et al., 2016), (Hutcheon, 2011) and (Veisllari, Bjornstad, Braute, Bozorgebrahimi & Raffaelli, 2015). Only connection-less (any-to-any) low granularity traffic, which requires routing function, still needs to cross IP/MPLS core network. As highlighted in Figure 2.9, network transformation process can start with efficient traffic engineering and bandwidth de-fragmentation exercise. This allows traffic distribution synergy between IP/MPLS and Optical (OTN over DWDM) layer (Yin et al., 2012). Service paths re-optimization based on MLO concept enhances the cost efficiency (Astely et al., 2009) and reduces route congestion and latency on longer paths (Santos et al., 2011).

### **2.5.3.2 Resources Optimization**

EONs is recently emerging to optimize resources in core networks. As a new solution for coarse granularity issue of DWDM ITU-T spectrum grid, it provides flexible and dynamic service in elastic OFDM. Efficient Routing, Modulation-level, and Spectrum Assignment (RMSA) algorithms are defined to optimize network resources by efficiently packing orthogonal sub-wavelengths in gridless and mini-grid spectrum at no interference risk. Connectivity capacities are dynamically served by Bandwidth Variable OFDM Transponder (BVT) that efficiently allocate optimal number of sub-wavelengths. On top of traditional OFDM network solutions based on single path routing, Z. Zhu et al. (Zhu, Lu, Zhang & Ansari, 2013) propose various elastic service provisioning algorithms using Hybrid single-/multi-path routing (HSMR)

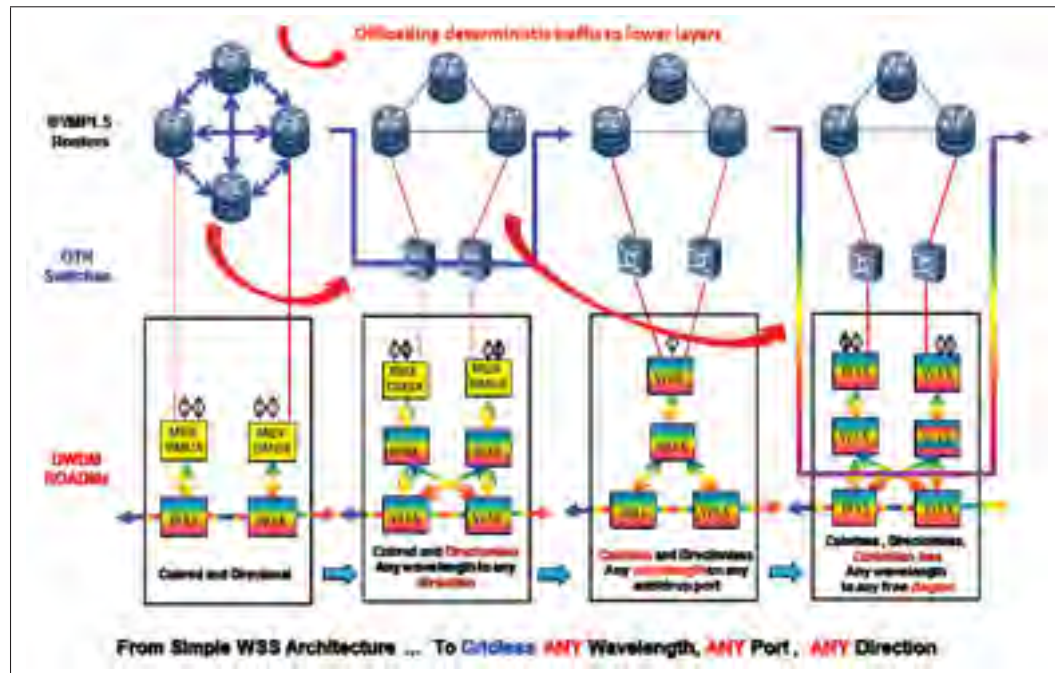

Figure 2.9 Offloading SP traffic to agile OTN and CDC DWDM lower layers

scheme. Data traffic is distributed with various path selection policies over multiple routing paths using dynamic RMSA algorithms and online/offline path computation mechanisms. In order to further increase spectrum efficiency for EON networks and significantly reduce OpEx, S. Zhang (Zhang, Martel & Mukherjee, 2013) investigate traffic grooming techniques using dynamic traffic models instead of traditionally static ones. A multi-layer auxiliary graph and a spectrum reservation scheme are introduced to optimize bandwidth allocation and address existing control plane problems related to electrical-layer routing as well as optical-layer Routing and Spectrum Assignment (RSA). The proposed auxiliary graph is based on edge weights that need to be tuned to optimize spectrum and transponder utilization. Furthermore, a novel service provisioning algorithm is proposed by (Lu, Zhu & Mukherjee, 2015) to minimize conflicts between hybrid service requests and improve spectrum utilization in EONs. Depending on requested service type and application QoS, bandwidth reservation scheme can be either based on Immediate Reservation (IR) for unspecified durations or Advance Reservation (AR) for future data transmission. Proposed proactive and reactive IR provisioning algorithms mini-

mize IR service failures (such as service blocking and traffic interruption) while AR scheduling algorithm addresses various IR traffic patterns to coordinate AR provisioning. Thus, resource utilization is enhanced in both time and spectral domains, and IR/AR service conflicts are considerably reduced.

### 2.5.3.3 Resilient Control Planes

#### a - Resiliency plan in current OTN/DWDM networks

*SP* benefits from existing distributed control plane protocols (e.g. G.ASON, GMPLS, and OSRP) and self-healing mechanisms offered by OTN over DWDM networks (Thyagaturu et al., 2016) and (Chamania et al., 2009). Strong end-to-end OAM tools enhance the reliability of the network and offer up to six-nines (99.9999%) network availability. Although wavelength-switching in WSON (Wavelength Switched Optical Network) based optical networks is much slower than ODU-switching at electrical level, *SP* decision was to activate both control planes (optical and electrical) to increase the resiliency of the optical transport network (OTN and DWDM) against multi-layer failures (Castro, et al., 2014). Thus, in case of network failures, there is more chance to recover by switching affected traffic to protecting ODUs on electrical layer as well as switching a whole bundle of wavelengths to alternative routes on the photonic layer. With proper settings, the system would always start by looking to protection paths using electrical control plane first. If no traffic recovery is possible on the electrical layer (by switching to free protection ODUs on alternative routes), then the optical control plane take the lead to switch the traffic on wavelength level and recalculates different routes for the whole affected lambdas. Control plane reliability and protection automation are extremely important features when evaluating new vendor OTN switches and DWDM multiplexers. Switching time during failures and scalability are most relevant parameters (Martinez et al., 2012). Protection mechanisms and related performance of the optical network should not be affected when the network is scaling up. Furthermore, PCE-based network control is under study and can also be introduced in the future in order to have stronger control plane and more efficient multi-layer traffic engineering (Muñoz et al., 2014), (Casellas et al., 2012) and (Castro, et al., 2014). De-



tails will be discussed in Section 5.3.

### **b - Resiliency plan in future SD-EONs**

Network survivability is a critical issue in optical networks to avoid traffic loss and SLA violation. More intelligent network control and management (NC&M) plane with global network view is required for future SD-EONs. Availability-aware differentiated protection (ADP) schemes (Chen et al., 2015) are being developed in SD-EONs to offer SLA based optimized and differentiated protection mechanisms while reducing failure recovery time. ADP algorithms adapt path protection scheme to different service availability requirements. The data plane includes BV-Ts and BV-WSS for lightpaths forwarding. Separate control plane consists of an OF controller (OF-C) (for resource management) and several OF agents (OF-AGs) within the network devices. On the control plane side, recovery time in legacy OSPF (open shortest path first) based networks takes more than a second. More recent segment protection schemes offer reduced link recovery time by switching failed traffic into pre-configured backup paths. However, segment protection approaches suffer from scalability issue due to greedy preplanned backup ports and paths for all links. To solve this issue, fast rerouting designs based on OpenFlow-based SD-EON significantly improve recovery time by reducing number of required rerouting flow entries and configuration messages (Kitsuwan, McGettrick, Slyne, Payne & Ruffini, 2015). A temporarily independent transient plane (ITP) is proposed in parallel with traditional working and control planes to take care of on-the-fly packets during failure time. Instead of waiting for forwarding instruction at the switch, introduced ITP will temporary forward packets already on route to destination until final backup path is set by the controller. Control plane resiliency in SD-EON is enhanced in (Chen et al., 2015) by introducing a redundant master-slave OpenFlow controllers (OF-Cs) design and a novel controller communication protocol (CCP). Real time network status synchronization between the Master and slave OF-controllers offers fast network control restoration in case of controller failure.

#### 2.5.3.4 Inter-domain service provisioning

OTN switches are introduced in the core network in order to offload deterministic traffic from IP layer. However, inter-domain service provisioning is still facing issues of creating end-to-end connectivities crossing different network domains. A centralized control plane in SD-EONs offers a global view of network resources and the possibility of flexible inter-domain service provisioning. The inter-domain protocol (IDP) and multi-domain cooperative RSA algorithm introduced by (Zhu et al., 2015) as well as the Hierarchical PCE (HPCE) architecture proposed in (Giorgetti et al., 2015) offer efficient end-to-end cross-domain path routing. Furthermore, a novel revenue-driven bidding strategy is presented in (Chen et al., 2016) predicting the behavior of competing brokers in order to optimize service pricing and enhance brokers' profit margins.

#### 2.5.3.5 End-to-end OAMP plan

In addition to Inter-domain service provisioning, OAMP inter-working limitations for end-to-end Ethernet service provisioning across the core network is also a big issue in optical networks. It can be addressed by extending the OTN capabilities up to the interfaces of routing components themselves (Nowell, 2009). In fact, by extending the OTN support up to the core routers, its OAMP capabilities are also extended to the routing network. Thus, a full end-to-end OTN OAMP inter-working is warranted between the OTN over DWDM based transport and IP/MPLS routing domains. If direct high capacity and ultra-low latency (ULL) connectivity is required, *SP* adopted the IP over DWDM architecture, where DWDM interfaces are extended into the switching or routing equipments (Rambach, et al., 2013). Therefore, the wavelength feeding the router travels in the transport network as a transparent channel avoiding, thus, all eventual OAMP inter-working issues. Beside the OAMP advantage, this network architecture offers *SP* more efficient MLO mechanisms, more resilient hybrid control planes and most cost-effective end-to-end network design (Nowell, 2009) and (Yin et al., 2012).



### 2.5.3.6 Agile photonic layer

On the pure photonic layer, DWDM is feeding all above layers with long-haul and ultra-long-haul high capacity pipes. Currently 100 Gbps channels are widely deployed in *SP* network. Higher capacity channels (super-channels of several Tbps) are becoming possible thanks to reduced granularity of grid-less (also called flex-grid) space where spacing between channels is reduced up to 12.5 GHz instead of 50 GHz (Rambach, et al., 2013). In order to keep this layer as agile as possible, *SP* further deployed massive costly Wavelength Selective Switch (WSS) in order to move their ROADMs from low-cost multi-directional wavelengths switching (Fixed Add/Drop) to more enhanced CDC ROADMs. CDC stands for Directionless (any Add/Drop to any line direction), Colorless (any wavelength on any Add/Drop) and Contention-less (same wavelength on multiple ports) ROADMs (Thyagaturu et al., 2016), (Mathew et al., 2015), (Zhang, Wang, Palacharla, Sekiya & Bihon, 2012), (Way, Ji & Patel, 2013). This allows client to re-route on failure, maximizing spectrum reuse and offers a good readiness for future automatic and programmable SDN-based control planes (Thyagaturu et al., 2016). Figure 2.9 summarizes *SP* DWDM infrastructure evolution plan to full flexible and agile Grid-less, Colorless, Directionless and Contention less (CDC) system in order to deal with all kind of upper layer service requirements (Thyagaturu et al., 2016). Figure 2.9 also highlights traffic offloading process from all dominant IP/MPLS routers to lower layers in order to enhance performance and reduce the CapEx and OpEx.

### 2.5.3.7 Resources monetization

Like the historical L3-VPN services, the lower layers infrastructure needs to start being monetized and generate new revenues. *SP* emphasizes on new business use cases based on Optical Virtual Private Networks (O-VPN) (Thyagaturu et al., 2016). By securing independent L0 40 Gbps and 100 Gbps set of lambdas or L1 set of ODU tunnels from the optical network and dedicate it to potential customers such as governments, universities, big enterprises, wholesale service providers, etc, these new customers benefit from total privacy and control of their network slices or segments. Faster service activation, restoration and performance monitor-

ing of private networks limited to assigned O-VPN attracts several customers and generate new revenues. The E2-IOPN is considered as a dynamic set of monetized resources and not anymore just CapEx-consuming transmission pipes (Wu, Savoie, Campbell & Zhang, 2007), (Ould-Brahim et al., 2003), (Kuri et al., 2003) and (Das, Naik & Patra, 2011).

## **2.6 SP longer-term strategy: SDN/NFV**

### **2.6.1 Why SDN?**

Brown-field and heterogeneous networks are facing a lot of control and inter-operability challenges due to the fragmented architecture with proprietary and vendor-specific interfaces. In particular, *SP* is focusing on the optical packet transport network in the metro and core layers as part of the whole SDN migration strategy plan. Different technologies are competing in this area. Most of them are presenting several control and management limitations that affect their efficiency as carrier grade transport solutions. Existing distributed control plane architecture has many complex functions baked into infrastructure. Decisions are made individually by switches, thus, cannot dynamically adapt to real-time network conditions. SDN is a very promising concept to address these issues where a centralized and unified multi-domain network control transparent to specific technology or equipment provider is becoming critical (Figure 2.10). Path Computation and the packet forwarding are controlled by an SDN Controller and no longer by the forwarding elements. All decisions are thus moved to the logically centralized controller whereas network switches only forward traffic based on the dynamically installed rules specified by the controller (Thyagaturu et al., 2016), (Chamania et al., 2009) and (Wang, Qi, Gong, Hu & Que, 2014).

### **2.6.2 Benefits of SDN for E2IOPN**

Based on the new concept, service creation is now part of the SDN control layer tasks which evaluates all the resources of the network at the same time and decides on the most efficient layer or technology to transport required traffic at a certain time. Thus, network traffic may

be operated, shaped, prioritized and managed dynamically as per the network traffic moves, users' requirements and consistent network policies. This allows: i) easier deployment of the networks, ii) dynamic resource allocation, iii) efficient network topology management and iv) traffic control for each "tenant" with a global view of the network. Furthermore, *SP* will benefit from scalable and automatic configuration of the network elements with a lot of room to innovations and programmability in different use cases from datacenter networks to wireless access networks. Some motivating uses cases for SDN application are related to overlay networking, neutral access networks, Virtual Private Network, and service-oriented networking. Automatic recovery (e.g. from software crashes) can be achieved also by directly integrating troubleshooting knowledge into network control applications. By using standard Openflow OF based network elements (called white-boxes), high cost proprietary hardware and special purpose devices will be easily avoided in the network (Chen et al., 2015) and (Wang et al., 2014).

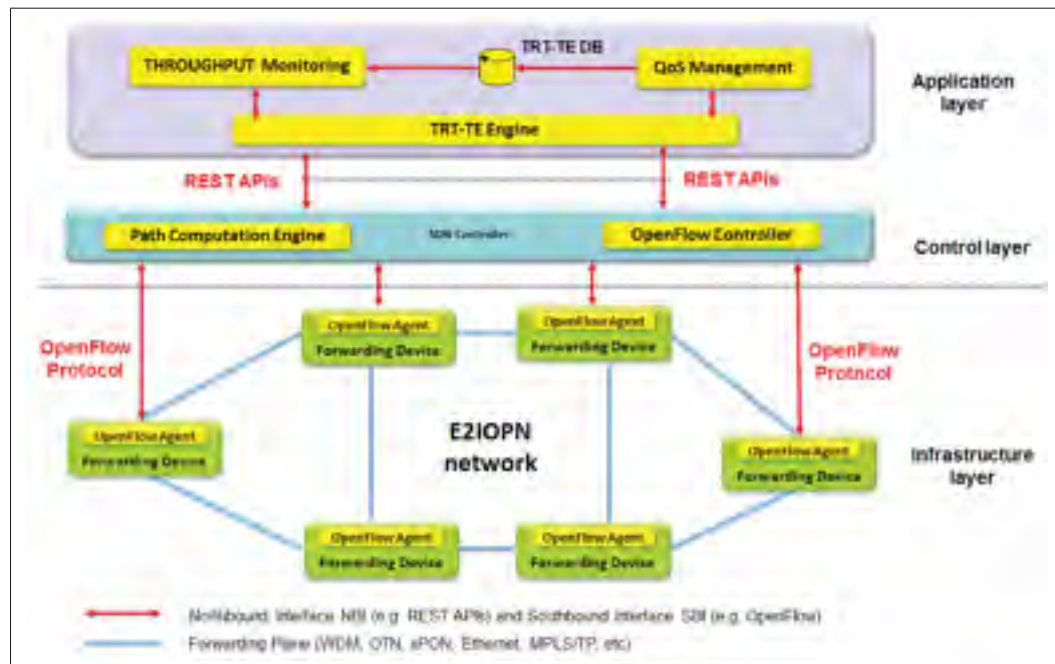

Figure 2.10 *SP* SDN vision in E2-IOPN using TRT-TE application

### 2.6.3 Challenges facing the migration to SDN

In E2-IOPN networks, SDN based solutions shall address the challenges of efficient network resources provisioning across the networks. Network traffic fluctuations and network status variation shall be automatically managed with end-to-end QoS guarantees. Efficient algorithms shall be further developed for the SDN controller entity in order to centrally retrieve required information from the underneath infrastructure. Thus, the SDN controller will be able to deal with congestion situations where the system is no longer able to support bigger traffic matrix (Thyagaturu et al., 2016) and (Scott-Hayward, Natarajan & Sezer, 2016). Furthermore, operating and troubleshooting mixed networks in heterogeneous environment where SDN devices and legacy devices co-exist are very challenging due to existing hardware and performance constraints. This is due to the limitations of the end-user device capabilities, the trust management and security issues, as well as the incremental deployment, robustness and scalability challenges (Scott-Hayward, Natarajan & Sezer, 2016). Flexible rules and actions are required. A further challenge service providers (including *SP*) are facing is the absence of standard northbound protocols for the communication interface between the SDN controller and the upper layer network applications (Li et al., 2015) and (Nishtha & Sood, 2015).

### 2.6.4 An SDN vision in E2-IOPN

The ultimate trend today in the industry is the migration to SDN control as part of the packet-optical network transformation process (Cyan Inc., 2014). In particular, Transport SDN (T-SDN) is an application of the SDN model on Packet-Optical Networks (Liu et al., 2014), (Casellas et al., 2012) and (Iovanna, Ubaldi, Di Michele, Gimenez & Lopez, 2014). The long-term vision of T-SDN in E2-IOPN is based on an unified centralized system based on simple, automatic and software-driven applications that will control the whole backhaul network in programmable way. In fact, a kind of *Centralized Control Plane* application that will run on top of an SDN Path Computation Engine (PCE) needs to be developed (Muñoz et al., 2014). The SDN controller discovers the network resources using standard interfaces (e.g. Openflow) and build detailed topology in its topology database (Choi et al., 2016). The whole ring will

be seen from a holistic view as a big switch with several geographically distributed ingress and egress interfaces. Based on various retrieved information and parameters from the access nodes, this application shall dynamically classify different types of traffic coming from last-mile network such as enterprises, residential or business CPEs, mobile backhaul traffic (2G, 3G, 4G and coming 5G) as well as network timing and signaling protocols, etc. Based on traffic classification outcome, the algorithm shall assign - more accurately - required bandwidth on real-time basis in a bandwidth-on-demand mechanism (Choi et al., 2016) and (Zhang et al., 2015).

### **2.6.5 Future work: a novel TRT-TE framework**

In particular, a future work plan is to define a framework to improve performance, QoS, availability, and efficiency of the MPLS-TP based transport network *in real-time*. Such framework named: *Throughput driven Real-Time Traffic Engineering (TRT-TE)* is proposed in Figure 10. In fact, Figure 2.10 highlights the architecture of the SDN based network control including a new TRT-TE module. A centralized bandwidth-on-demand application will automatically map each service in a prioritized PWs based on specific CoS and service constraints (Zhang et al., 2015). New traffic engineering techniques will be developed to enable fast end-to-end service provisioning. Instead of user pre-defined static tunnels based on peak traffic rates, a new throughput monitoring module as well as a QoS management module within the TRT-TE application (Figure 2.10) will dynamically control the size of MPLS-TP tunnels based on real-time retrieved ingress traffic throughput fluctuations as well as on specific CoS and service constraints (Murakami et al., 2014) and (Wang et al., 2014). With this concept, much more efficient Traffic Engineering can be achieved to enhance network resources utilization while maintaining good QoS. In particular, the network capacity within the backhaul networks will be properly allocated. *SP* will benefit from programmable, flexible, and scalable networks with end-to-end control, dynamic end-user services classification and elastic bandwidth computation based on ingress throughput. Service constraints and related QoS parameters will be stored in a DB as part of the TRT-TE application.

A distributed VNF based agent in the access nodes retrieves and pushes real-time information that will be used for dynamic path computation (Thyagaturu et al., 2016) and (Muñoz et al., 2014). Ingress service throughput variation can be retrieved by the VNF agent using for instance the throughput measurement OAM parameter within MPLS-TP OAM toolset. The PCE in the SDN control layer in Figure 2.10 calculates the path and pushes related instructions to devices using the standard Openflow protocol (regardless of the equipment vendor). Thus, the forwarding plane of the network elements will follow the coming instructions and setup the path. This concept can be extended to cover end-to-end service path computation across both MPLS-TP, OTN over DWDM and IP/MPLS domains as a common and unified *Centralized Control Plane* (Casellas et al., 2012) and (Martínez, Casellas & Muñoz, 2011).

## 2.7 Cost comparative study

In this Section, we present a CapEx and OpEx comparative study performed by *SP* using competing mobile backhaul technologies to built and operate a greenfield backhaul network. The network model is based on access rings collecting 2G, 3G and 4G traffic coming from several mobile towers in the RAN (or even different enterprise offices in the last-mile network). Traffic is collected by eight access equipment and aggregated in two redundant aggregation systems homed in the CO or POP before being forwarded to the core network.

The general equations used by *SP* to estimate the CapEx and 5 years OpEx of such network are provided by (2.2) and (2.3). The model parameters are presented in Table (2.4).

$$\begin{aligned}
 CapEx = 2 * (CapEx_{Basic}^{Agg} + \sum_{m=1}^M CapEx_{mod}^{Agg}[m]) \\
 + \sum_{r=1}^E \sum_{e=1}^E (CapEx_{Basic}^{Acc}[r][e] + \sum_{n=1}^N CapEx_{mod}^{Acc}[r][e][n]) \quad (2.2)
 \end{aligned}$$

Table 2.4 CapEx and OpEx Model parameters

Parameter	Definition
r	number of access rings (r=1..R)
e	number of access equipment per ring (e=1..E)
m	number of modules within aggregator (m=1..M)
n	number of modules within access eqpt. (n=1..N)
y	number of operating years (y=1..Y), usually Y=5
$CapEx_{Basic}^{Agg}$	Aggr. basic hardware cost (chassis, switching, power, management modules)
$CapEx_{mod}^{Agg}$	Aggregator modules deployment cost
$CapEx_{Basic}^{Acc}$	Access equipment basic hardware cost
$CapEx_{mod}^{Acc}$	Access equipment modules deployment cost
$OpEx_{Basic}^{Agg}$	Aggr. basic operation costs (Licensing Keys, warranty, managed services)
$OpEx_{mod}^{Agg}$	Aggr. modules operation cost (Right-to-Use, spare parts, maintenance costs)
$OpEx_{Basic}^{Acc}$	Access equipment basic operation cost
$OpEx_{mod}^{Acc}$	Access equipment modules operation cost
TC	Training cost for operating engineers

$$\begin{aligned}
OpEx = 2 * \sum_{y=1}^Y (OPX_{Basic}^{Agg}[y] + \sum_{m=1}^M CPX_{mod}^{Agg}[y][m]) + \sum_{y=1}^Y (TC[y] \\
+ \sum_{r=1}^R \sum_{e=1}^E (OPX_{Basic}^{Acc}[y][r][e] + \sum_{n=1}^N CPX_{mod}^{Acc}[y][r][e][n])) \quad (2.3)
\end{aligned}$$

subject to:

$$CapEx[y] + OpEx[y] \leq TCO[y] \quad \forall y = 1..Y, \quad (2.4)$$

$$\sum_{y=1}^Y (CapEx[y] + OpEx[y]) \leq TCO_{Total} \quad (2.5)$$

Three types of technologies were proposed during the estimation phase to serve the ring requirements as well as the UNI interfaces in models 1 and 2 :

- MPLS-TP solution with Static control plane show as *S1, S2, S3, S4, S5 and S6* (a)
- MPLS-TP solution with Dynamic control plane (RSVP-TE and LDP-TE) show as *D* (b)

- IP based solution shown as *R1* (seamless MPLS) and *R2* (IP/MPLS Routers) (c)

Table 2.5 Packet and TDM drop interfaces in Model 1 and Model 2 devices

Models	FE Electrical	FE / GE Optical	STM-1	E-1
Access equipment Model 1	4	4	0	0
Access equipment Model 2	4	4	4	12
Aggregator Model 1	12	12	0	0
Aggregator Model 2	8	8	12	24

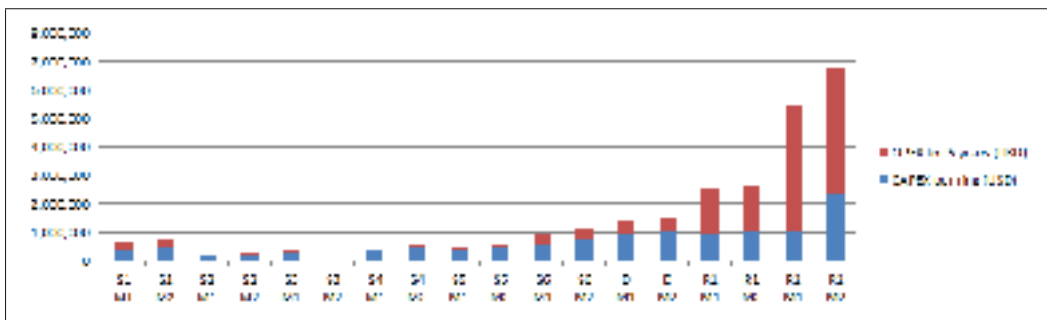

Figure 2.11 Cost comparative study using different transport technologies

where:

- (i) *M1* and *M2* are two device models (resp. pure packet vs packet + TDM drop),
- (ii) *S1, S2, S3, S4, S5 and S6* are MPLS-TP devices with Static control plane,
- (iii) *D* is an MPLS-TP device with Dynamic control plane (RSVP-TE and LDP-TE),
- (iv) *R1* and *R2* are IP based solutions (resp. seamless MPLS and IP/MPLS Routers)

In *SP* comparison, the same mobile backhaul ring model described in Figure 2.8 is used where eight access devices are sharing a 10 Gbps capacity. Each access device is connected to the aggregator through a 1+1 protected tunnels. Each working tunnel in the clockwise direction is protected by a single protection tunnel with the same size in the counter-clockwise direction. The used data is collected from the market prices. Several global Solution Supplier (SS) participated in a Request for Proposal (RFP) competition where each one provided his best technical and financial offer. Two fixed access and aggregation equipment configuration models were



defined to fairly benchmark the solution offered by each SS. All SSs calculated their costs based on the network model diagram given in Figure 2.8.

The aggregators should have capability to connect multiple 10 Gbps rings. Two solution models were requested by *SP* to backhaul the traffic: i) model 1 is offering pure Ethernet client interfaces and ii) model 2 is adding E1 and STM-1 interfaces to the required drop interfaces in both access and aggregator equipments in order to satisfy pure TDM-based UNI interfaces. The number of drop interfaces for the equipment Model 1 (M1) and Model 2 (M2) is shown in the table 2.5. The two models were quoted with the best of their performance including the total cost of the ten equipment with all required cards and interfaces (CapEx) as well as the 5-years cost of managed services to operate each ring (OpEx). These costs are used by *SP* as a reference to estimate the transformation project cost for targeted *R* backhaul rings in the whole network (Polito et al., 2011) and (Rambach et al., 2013).

Results show the big cost difference in particular for the operation of the ring. MPLS-TP solution with static control plane offered the minimal CapEx and OpEx costs compared with solutions using MPLS-TP with dynamic control plane or L3 IP/MPLS technologies. The costs are relatively comparable between *S1*, *S2*, *S3*, *S4*, *S5* and *S6* from six different SSs. This is due to the simple architecture of MPLS-TP solution which is based on low-cost Ethernet technology reducing all the complexity of dynamic control plane and L3 protocols. Network managed services are relatively simple and low-cost since it is a continuity to SDH-like network operation in terms of troubleshooting, maintenance and service provisioning. Solution *D* is more expensive due to the use of dynamic control plane which involves various higher layer protocols that make the cost of the equipment and its related operation cost much higher. Solutions based on L3 protocols (*R1* and *R2*) are extremely expensive. A comparison between the most expensive (*R2*) and the cheapest solution (*S2*) costs in model 1 shows that CapEx of *R2* is about 6 times more expensive than *S2* while 5-years OpEx is tens times more expensive. These results are matching perfectly with the economic study of (Gunawardana & Shastri, 2011) using multi-purpose switches instead of IP Core Routers and validate the X2 interface backhaul design discussed in Section 4-B.

SP is still having massive TDM-based UNI interfaces in the access devices. This traffic needs to be collected and carried to the aggregation equipment in the POP in parallel with the pure Ethernet traffic. Thus, Model 2 is adding E1 and STM-1 interfaces on top of Model 1 in both access and aggregation sites in order to be able to deal with legacy TDM based services. In this model, Layer 3 equipments are not very adapted to E1 and STM-1 traffic. Thus, the cost of the equipment shows again a huge increase from Model 1 to Model 2 for the routers. The CapEx of *R2* is more than doubled and is ten times more expensive than *S2*. Thus, it is reaching a level that affects the scalability of the network. *SP* cannot afford transforming a large-scale networks using such extremely expensive solutions both in terms of CapEx and OpEx. This confirms our choice to go for MPLS-TP solution for all enterprise and mobile backhaul traffic. The use of L3 routers shall be reduced to only any-to-any non-deterministic traffic in the core network. With proper designs and traffic engineering, everything else can be offloaded to lower layers (e.g., MPLS-TP, OTN, and lambda).

## 2.8 Conclusion

Several service providers already started the transformation of their networks in order to meet the new challenges. E2-IOPN is offering simplicity, flexibility and scalability they are looking for. In this paper, we review various empirical challenges faced by a Service Provider *SP* during his transport network transformation project towards an End-to-End Integrated Optical-Packet Network as well as the high-level as-built design including related implemented solutions. Thanks to its non-powered (passive) optical splitters, GPON is an Ethernet based solution that offers FTTH access networks consistency and high bandwidth per user while maintaining low costs and energy consumption. MPLS-TP presents better results in the access and metro access backhaul networks. Existing legacy TDM based services are still considered thanks to the multi-service emulation mechanism (PWE3). Integrating MPLS-TP as a backhaul solution with the IP/MPLS core network offers faster end-to-end service provisioning with enhanced Traffic Engineering capabilities and higher performance monitoring using MPLS Diff-serv aware QoS. Offloading most of existing deterministic traffic directly to OTN

switched network in the core and metro aggregation networks reduces the stress on layer 3 routers, optimizes resource utilization and reduces the need for expansions. A combination of strong resiliency and low-latency capabilities, high capacities of Grid-less DWDM channels and flexibility of CDC ROADMs (Colorless, Directionless and Contention-less) offers the core and metro core networks a very high availability and scalability. Self-healing network capability provides restoration without duplication of equipments and minimizes the bandwidth usage (Thyagaturu et al., 2016).

Finally, combining the benefits of these recent state-of-the-art Packet-Optical network technologies with multi-layer SDN platforms will address a lot of big painful challenges *SP* is still facing. This combination will provide *SP* with an end-to-end SDN and NFV controlled network. The centralized control applications will dynamically classify different types of services coming from last-mile network, adapts required bandwidth based on bandwidth-on-demand mechanism and finally automatically maps each type of service in protected LSPs and prioritized PWs based on specific CoS and service constraints. The transformation of the access, metro and core transport networks towards an End-to-End Integrated Optical Packet Network E2IOPN enables network resources optimization, CapEx and OpEx reduction and much better quality of service to end-users. Moreover, this will help *SP* sustain to new market changes and maintain good profit margins, which is crucial for the evolution of all service providers' networks regarding the advent of new 5G and cloud computing applications.



## CHAPTER 3

### **BACKHAULING-AS-A-SERVICE (BHAAS) FOR 5G OPTICAL SLICED NETWORKS: AN OPTIMIZED TCO APPROACH**

Nassim Haddaji<sup>1</sup>, Abdolkhalegh Bayati<sup>1</sup>, Kim-Khoa Nguyen<sup>2</sup>, Mohamed Cheriet<sup>1</sup>

<sup>1</sup> Department of Automated Production Engineering, École de Technologie Supérieure (ETS),  
1100 Notre-Dame Ouest, Montréal, Québec, Canada H3C 1K3

<sup>2</sup> Department of Electrical Engineering, École de Technologie Supérieure (ETS),  
1100 Notre-Dame Ouest, Montréal, Québec, Canada H3C 1K3

Article published by IEEE, "IEEE/OSA Journal of Lightwave Technology", July 2018.  
Digital Object Identifier: 10.1109/JLT.2018.2855148

#### **3.1 Abstract**

Due to their initial over-estimation of demand, many network operators are over-provisioning their infrastructure. Over-designed networks vastly increase operational costs without generating expected revenues. In particular, high density cell architecture in future 5G networks will face big technical and financial challenges due to avalanche of traffic volume and massive growth in connected devices. Planning scalable 5G Mobile Back-Haul (MBH) transport networks becomes one of the most challenging issues. However, existing planning solutions are no longer appropriate for coming 5G requirements. New 5G MBH architecture emphasizes on multi-tenancy and network slicing which requires new methods to optimize MBH Planning resource utilization. In this paper, we introduce an algorithm based on a stochastic geometry model (Voronoi Tessellation) to define backhauling zones within a geographical area and optimize their estimated traffic demands and MBH resources. Then, we propose a novel method called BackHauling-as-a-Service (BHaaS) for network planning and Total Cost of Ownership (TCO) analysis based on "You-pay-only-for-what-you-use" approach. Finally, we enhanced BHaaS performance by introducing a more service-aware method called Traffic-Profile-as-a-Service (TPaaS) to further drive down the costs based on yearly activated traffic

profiles. Results show BHaaS and TPaaS may control and enhance 22% of the project benefit compared to traditional TCO model.

**Keywords:** 5G, Optical Mobile Backhaul, Voronoi, BHaaS, TPaaS, CapEx, OpEx, TCO, ROI, Traffic Profiles.

### 3.2 Introduction

The coming 5<sup>th</sup> generation of mobile networks expected in 2020 is bringing new challenges to network architecture of Mobile Network Operators (MNO). Future 5G technology is more service aware offering applications with very strict requirements. An exponential growth in traffic demand and the number of connected devices is leading to high network costs and scalability challenges. Small cell technology is emerging with a very high density (may reach up to 1500 cells per km<sup>2</sup> in coming years including femtocells as highlighted by (Jaber, Imran, Tafazolli & Tukmanov, 2016). MNOs started re-thinking the architecture of their networks in order to connect the increasing number of small cells while keeping the costs as low as possible (Khan, Leng, Xiang & Yang, 2015).

Coming 5G technology is bringing new requirements that will drive the transformation of the entire network from last-mile and access layers, to backhaul and aggregation and up to core and control layers. Together with front-hauling, Mobile BackHaul network (MBH) represents main challenges (33% of the entire 5G challenges as per Light Reading Magazine, April 2015). Due to high cost of implementation, expansions and operations, MBH is contributing more than 50% to future small cell networks expenditures (Wang, Hossain & Bhargava, 2015). More efficient and innovative planning and design tools are required to control the costs of deploying new MBH projects as well as expanding already existing networks. Total Cost of Ownership (TCO) analysis is a critical step in the planning and validation of entire project life-cycle expenses. It allows making optimal decisions for acquiring, deploying, activating and operating of intended assets and infrastructure resources. TCO is calculated by adding initial CapEx (CAPital EXpenditure) to five years OpEx (OPERation EXpenditure) based on published prices

from the industry. Several solutions are being investigated to reduce new 5G MBH TCO. They either try to adapt and take advantages of traditional transport networks (e.g. microwave, copper and optical fiber) or to evolve into new introduced software-based technologies that may drop costs of network deployment (Gupta & Jha, 2015) and (Khodashenas et al., 2016).

Wireless technologies like massive MIMO (Multi-Input-Multi-Output) antenna, visible light communication and millimeter-Wave (mmW) are actual technologies that will be adopted in 5G MBH, although some of these solutions are preferred in rural areas. For many operators, optical fiber technology remains preferable solution for 5G MBH thanks to its unlimited capacities, long reach, high performance and low latency. Particularly, Passive Optical Network (PON) technology and its variants are emerging as a low-cost MBH solution (Ranaweera, Iannone, Oikonomou, Reichmann & Sinha, 2013). Among current optical technologies, like tree, mesh, and ring, optical rings are preferable choice for long distance MBH thanks to high reliability and scalability for big networks (Nag, Furdek, Monti, Wosinska & Ruffini, 2016). Optimal planning of optical MBH networks is a high complexity problem due to very high density and random architecture of 5G networks as well as the variety of 5G traffic profiles (Mukhopadhyay & Das, 2015). Massive expansions and replacing existing microwave links by fiber are very costly solutions. Excessive procurement of unused devices, modules and interfaces shall be avoided unless imminent activation is required. Uncontrolled deployment, expansion and operation costs of such huge MBH raises initial costs and long-term TCO. This may result in bottlenecks that affect network scalability and reliability (Jaber et al., 2016). Thus, efficient planning of scalable and profitable MBH is required. Innovative MBH solutions and more accurate estimations of CapEx and OpEx are substantial to optimize network TCO and improve its scalability.

In this paper, we propose a novel TCO analysis method that can be implemented as a decision-helping module within optical MBH network planning tools to optimize MBH resource distribution and activation time over project lifetime based on estimated traffic demand and generated revenues. Our main contributions are following:

1. A comprehensive CapEx and OpEx calculation model for optical MBH networks.
2. A novel TCO analysis BackHauling-as-a-Service (BHaaS) method based on "You-pay-only-for-what-you-use" to optimize yearly planned installation and activation of resources based on estimated traffic demands and generated revenues.
3. An advanced Traffic-Profile-as-a-Service (TPaaS) method that further optimizes TCO based on planned activation time and costs of traffic profiles.
4. A novel algorithm based on Voronoi Tessellation stochastic geometry algorithm to define backhauling zones within a geographical area and optimize their estimated traffic demands.

The remainder of the paper is organized as follows. The related work on 5G MBH cost optimization is reviewed in Section II. Problem statement and research framework are defined in Section III. Proposed solutions including TCO formulation, BHaaS and TPaaS models and a Voronoi based algorithm are presented in Section IV. Performance evaluation is presented in Section V. Finally, we conclude the paper and present future work.

### **3.3 Related work**

#### **3.3.1 5G MBH Solutions: TCO approach**

Several technologies and techniques are proposed in the literature to plan efficient 5G MBH with reduced long-term TCO (Khan, Kellerer, Kozu & Yabusaki, 2011). Fig. 3.1 summarizes wireline approaches discussed in this section where ETN is the Edge Transport Node and ATN is the Aggregation Transport Node. (La Oliva et al., 2015) and (Mur, Flegkas, Syrivelis, Wei & Gutiérrez, 2016) emphasize on the novel concept of Crosshaul (Xhaul) as a cost-effective architecture. Xhaul architecture is defined by integrating 5G backhaul and fronthaul transport networks for flexible and heterogeneous transmission links. Different network architecture (tree, ring, etc) are integrated in a unified Xhaul packet Forwarding Element (XFE) and controlled by a central processing unit to reduce CapEx and OpEx. (Kolydakis & Tomkos, 2014)



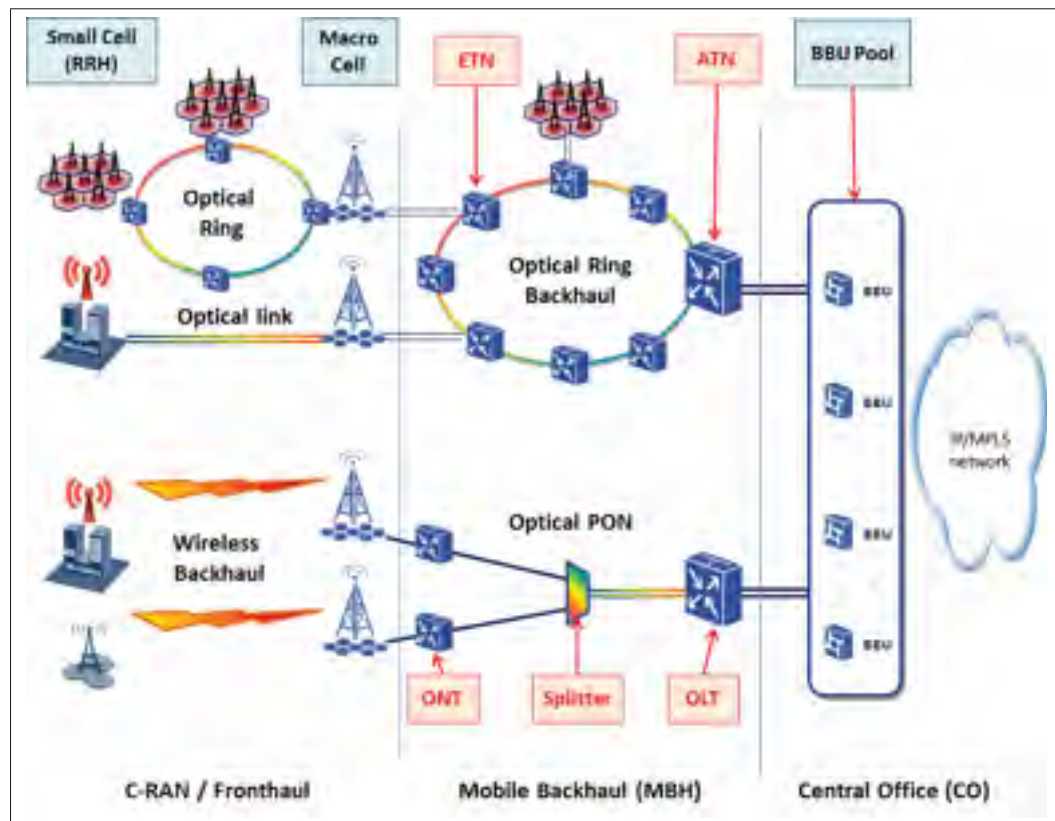

Figure 3.1 Crosshaul network architecture (Fronthaul + Backhaul) for future 5G mobile networks.

proposes a TCO comparison between wireless and fiber technologies in 5G fronthaul and backhaul solutions which shows that fiber is more cost effective than wireless in high density areas (less than 1 km spacing distance between adjacent eNodeBs).

From evolving fiber solutions perspective, (Ranaweera et al., 2013) discusses advantages of PON technology in reducing up to 60% of 5G MBH cost. Traffic is collected by Edge Transport Nodes (ETN) and forwarded to Aggregation Transport Nodes (ATN) using the optimized fiber routes, locations of splitters, and number of ports. (Sung, Chow, Yeh & Chang, 2015) adopts spectral-efficient OFDM (Orthogonal Frequency Division Multiplexing) modulation technique and proposes an Optical Distribution Network (ODN) sharing scheme based on existing PON infrastructure to avoid deploying new fiber cables. (H. Chen et al., 2016) applies K-means clustering and a multi-stage access nodes strategy with shared cable ducts and introduces a

cost-effective solution based on TWDM-PON (Time and Wavelength Division Multiplexed PON) to optimize cost of dense 5G MBH. These solutions assume all OLTs covering the whole geographical area are co-located in a single Central Office (CO). Several cost modeling and optimization methods have been presented for optical network TCO analysis. (Jarray, Jaumard & Houle, 2010) proposes CapEx and OpEx cost modeling and a MILP (Mixed Integer Linear Programming) optimization method for large scale mesh networks based on column generation techniques and a rounding off heuristic. (Mahloo, Monti, Chen & Wosinska, 2014) introduces a comprehensive TCO evaluation model for small cells MBH by identifying critical cost drivers affecting CapEx and OpEx. (Zefreh, Tizghadam, Leon-Garcia, Elbiaze & Miron, 2016) proposes a MILP model to minimize CapEx for multi-chassis routers and multi-rate line cards in IP over optical networks. Their proposed optimization is limited to initial (day one) CapEx calculation while OpEx was not considered.

Nevertheless, cost calculation models in prior work are driven by initial estimated hardware quantity and prices. Costs of basic equipment and related modules (subrack, management and power modules, switching fabric, user interfaces, etc) are all considered in the initial cost calculation even before they actually carry traffic and generate revenue. Their TCO models do not scale with the growth of service and generated ROI (Return On Investment). Continuous expansion of MBH physical networks based on current cost models will drastically increase network TCO for future very high density 5G networks. Innovative planning tools based on dynamic activation, pay-as-you-grow pricing and yearly distribution of traffic demand need to be developed to avoid over-provisioning infrastructure. This will help split project costs over several years and avoid high kick-off project budgets. Moreover, costs of various service-aware traffic profiles have to be taken into account according to different end-user Service Level Agreements (SLA) and generated revenues.

### **3.3.2 Multi-tenancy and Network slicing in 5G MBH**

Multi-tenancy and network slicing are novel approaches to offer service-aware and cost-efficient 5G networks. (Costa-Requena, Santos & Guasch, 2015) emphasizes on the importance of in-

tegrating recent SDN (Software Defined Networking) and NFV (Network Function Virtualization) concepts in optimizing 5G MBH resources and saving up to 14% of CapEx. (Kholdashenas et al., 2016) presents infrastructure multi-tenancy within 5G SESAME project by sharing the physical resources among various MNOs, service providers and Over-the-Top (OTT) users. (Mur et al., 2016) presents a network slicing solution based on dynamic partitioning and sharing physical resources among several virtual networks. (Zhou, Li, Chen & Zhang, 2016) introduces the concept of hierarchical Network Slicing as a Service (NSaaS) where customized end-to-end network slices are offered to MNOs as a service with enhanced slice management and quality assurance mechanisms. (Sama, Beker, Kiess & Thakolsri, 2016) discusses requirements of coming applications and services in 5G era and propose a new mechanism for multiple slicing based on required service type. (Bakhshi & Ghita, 2016) defines six unique traffic profiles based on NetFlow, cluster analysis and users application usage trends for future networks monitoring, policy enhancement and anomaly detection. Nevertheless, these solutions are not considered in TCO analysis. They rather rely on deterministic connectivities with static resource allocations and service-agnostic pipes. Resources are transparently allocated regardless of service SLAs and revenues. The pricing of traffic profiles is not considered in the costs of user interfaces and results in unfairness in TCO calculation. A wiser and more adaptive service-aware resource activation should be defined to reduce CapEx and OpEx and enhance 5G network scalability.

### **3.4 Problem statement and system definition**

In this paper, we consider the scenario in which a Telecom Service Provider (TSP) is planning an optical transport network to offer MBH connectivity services to a number of MNOs by leasing separate network slices. The goal is to minimize the costs of acquisition and deployment of the new MBH network, both in terms of CapEx and OpEx, and maximize revenues (ROI). This will be achieved through TCO analysis which results in an optimized plan for demand distribution over time. We defined in a previous work (Haddaji, Nguyen & Cheriet, 2017) a traditional TCO calculation model used by current TSPs to estimate CapEx and 5-years OpEx

of the optical MBH. Proposed BHaaS and TPaaS models in this paper calculate optimal costs ahead of the network installation phase. Traffic demand is specified by the customers for the total project lifetime (for instance, 5 years). This demand cannot be reduced. However, it can be estimated more precisely through an efficient partition of backhauling zones defined by the location of the ATNs. The proposed models distribute this demand over project years to optimize the total cost. No network element is installed but only planned in this TCO analysis phase. CapEx and OpEx of these elements will be added to their total cost of activation when they are really selected by BHaaS/TPaaS to be provisioned. The models result in no pre-installed device which is not yet active. User traffic demand which does not generate immediate revenue will be postponed later to a subsequent year when its ARPU (Average Revenue Per User) becomes positive.

ATNs are usually co-located within COs with mobile controllers (BSC, RNC, MME/SGW and coming 5G BBU pools) (Mukhopadhyay et al., 2015). The number and locations of COs are given by TSP. Traffic demand is collected from small cell towers by ETNs and aggregated in dual-homed ATNs. Input parameters and decision variables are respectively detailed in Tables 3.1 and 3.2. ATN and ETN CapEx includes basic hardware cost (chassis, switching, power and management modules, deployment fees, etc) while their OpEx includes basic operation costs (RTU Right-to-Use and licensing keys, spare parts and warranty, managed services and maintenance costs, etc). TSPs usually plan and build required fiber cables prior to equipment installation phase. Whenever required, newly installed hardware equipment are connected to free pairs of fiber within shared fiber cables (for instance, 144 pairs of fiber per each cable) (Ranaweera et al., 2013).

We focus first on ring-based optical MBH use case presented in Fig. 3.2 as a more reliable and scalable solution for long distance optical networks then we validate our work on low-cost PON-based networks. The proposed TCO model is applied for PON networks by substituting ATNs by OLTs and ETNs by ONTs as shown in Fig. 3.1 and in Section 3.4.1.

### 3.4.1 Proposed Backhauling-as-a-Service (BHaaS) method

(Jaber et al., 2016) introduced the concept of Backhaul-as-a-Service (BHaaS) as a consolidated vision for self-optimized 5G backhaul. Recent backhaul technologies are combined under the holistic control and coordination of centralized SDN intelligence. Real-time network data is dynamically retrieved from multiple MNO networks and adapted actions are pushed to underneath network infrastructure. Massive devices, modules and interfaces (ports) are often running in several TSP networks without carrying traffic. They are usually deployed since day one (as initial CapEx) and continue consuming space, power and maintenance fees (OpEx) without generating any revenue. We propose a Backhauling-as-a-Service (BHaaS) cost modeling method to optimize the network TCO and improve the project benefit. BHaaS is based on “You-pay-only-for-what-you-use” approach to help TSP analyze and validate, among others, his financial capability to build, operate and serve his customers within his limited budget (defined as a constraint in the optimization model). TCO and ROI are optimized for every year of the project runtime based on estimated Total Traffic Demand (TTD), hardware manufacturers yearly UPLs (User Price Lists) and yearly maximum assigned budget. The proposed model plans *a priori* the optimal time when equipment has to be purchased and activated to afford demand. No cost is registered until the moment when the equipment is actually acquired and activated. Installation cost will be added to the total cost of activation. BHaaS distributes the deployment time of devices on yearly basis based on TCO and ROI optimization. If a resource cannot improve TCO, then BHaaS will postpone its activation to future date after the first year to maximize the benefits. In any case, the total demand will be completely afforded when the project ends. As a result, BHaaS concept helps TSPs to:

- define the optimal time to kick-off the MBH project and when to purchase, commission and activate devices to fully satisfy traffic demand.
- prioritize traffic demands that actually generate revenues. Best-effort traffic with low income may be postponed to next year.
- avoid over-designed and unnecessary activated resources.

- optimize kick-off budget in the first year by fairly distributing the total project budget over all project implementation years.

### 3.4.2 Proposed Traffic-Profile-as-a-Service (TPaaS) method

In prior network TCO analysis, only hardware costs of ETN devices, modules and interfaces are taken into account. No service cost is considered whether they carry low-cost best-effort or expensive critical traffic. Their CapEx and OpEx are not proportional to carried service, SLAs and generated revenues. On the other hand, 5G multi-tenancy and network slicing architecture is more service-driven and shared by several tenants. The price of various service types with different traffic profiles should be defined accordingly. Thus, we introduce the concept of Traffic-Profile-as-a-Service (TPaaS) to improve the precision of the previous BHaaS method by separately and properly pricing each traffic profile based on its policies and Class-of-Service (CoS). In our model, only activated Priced Traffic Profiles (PTP) within ETN interfaces (point of attachment) are considered in the TCO and ROI calculation. If no PTP is activated in an ETN interface, then the entire interface is idle and thus excluded from the total TCO calculation. Similarly, if no interface is activated in ETN module, the entire module is not considered. TPaaS concept offers various benefits:

- Costs of each slice of shared infrastructure is specified for available PTPs.
- Long-term network TCO is optimized for multi-tenant 5G networks.
- Beyond simple connectivity, traffic profiles within TPaaS offer new types of services and define new revenue generation models.

We apply TPaaS on a PON-based MBH network using the same  $N_{TD}$  and TTD. Splitters cost is inclusive in the CapEx of corresponding interfaces in the OLT. As ONT has no subrack or modules, the number of its module is 1 ( $N_{mod}^E = 1$ ). Splitting ratio (e.g. 1:16, 1:32 or 1:64) is required in PON point-to-multi-point architecture and is equal to the number of ONTs per each OLT interface ( $N_{sub}^E = 32$  in our use case). The PON link between the OLT and the outdoor

splitter cabinet is also protected by a redundant OLT interface (see Fig. 3.1). Thus, both PON and ring-based networks require a pair of interfaces in the ATN (or OLT) towards the access network.

### 3.5 Cost modeling

Let:

$T = \{\text{ETN, ATN}\}$  : Transport nodes ETNs and ATNs

$C = \{\text{subrack, module, interface, fiber}\}$  : Components inside each transport node  $t \in T$

Table 3.1 Decision Variables

Name	Description
TCO	Optimal amount of TCO
ROI (YROI)	(Yearly) Return-On-Investment
$CX[y]$	CapEx in year $y$ (Vector of Integers)
$OX[y]$	OpEx in year $y$ (Vector of Integers)
$P_{TD}$	Satisfaction of Traf. Demand (Matrix of Booleans)
$P_c^t$	Activation of $c \in C$ within $t \in T$ (Binary)

#### 3.5.1 Traditional TCO cost model,

Traditional TCO analysis of MBH projects usually calculates entire hardware infrastructure required to afford traffic demand for a number of years  $Y$  (in general, 5 years) (Haddaji et al., 2017).

$$TCO[Y] = \sum_{y \in Y} (CX[y] + OX[y]) = \sum_{y \in Y} \sum_{t \in T} \sum_{c \in C} (CX_c^t[y] + OX_c^t[y]) \quad (3.1)$$

**Subject to:**

$$0 \leq TCO[y] \leq TCO_{Max}[y], \forall y \in Y \quad (3.2)$$

$$TCO[Y] \leq PB_{Max}, \quad (3.3)$$



Table 3.2 Problem parameters

Name	Description
$PB_{Max}$	Maximum project budget
Y	MBH project runtime in Years
$ARPU_x$	Average Revenue Per User x
$N_{TD}$	Traffic demand per ETN module
$N_{TP}$	Traffic profiles per ETN module
TTD	Total traffic demand in entire network
$tp, tp \in TP$	Traffic profile
$\epsilon_{CX}[y], \epsilon_{OX}[y]$	All-in-one volume discount in year y
$CX_c^A, CX_c^E$	CapEx for Component $c \in C$
$OX_c^A, OX_c^E$	OpEx for Component $c \in C$
$N_c^A$	Total number of Comp. c in all ATNs
$N_c^E$	Total number of Comp. c in all ETNs
$C_{sub}^A$ (Voi, size: $N_{sub}^A$ )	Bind subrack to ATN
$C_{mod}^A$ (Voi, size: $N_{mod}^A$ )	Bind module to subrack in ATN
$C_{inf}^A$ (Voi, size: $N_{inf}^A$ )	Bind interface to module in ATN
$C_{sub}^E$ (Voi, size: $N_{sub}^E$ )	Bind subrack to ETN
$C_{mod}^E$ (Voi, size: $N_{mod}^E$ )	Bind module to subrack in ETN
$C_{TD}^E$ (Voi, size: $N_{TD}$ )	Bind T.D. to module in ETN

Eqs. (3.1) calculates» the TCO for the project lifetime (Y) by adding deployment and operating costs of all estimated transport nodes  $t \in T$  and related components  $c \in C$ . Eq. (3.2) states that the TCO is limited in each year while Eq. (3.3) states that the total project budget is bounded.

### 3.5.2 Proposed BHaaS cost model

The objective of proposed BHaaS cost model is formulated in Eq. (4.1) to minimize the entire project cost TCO versus ROI (i.e. maximize the project benefit):

$$\text{minimize } (TCO[Y] - ROI[Y]) \quad (3.4)$$

where:

$$ROI[Y] = \sum_{y \in Y} YROI[y] = \sum_{y \in Y} \left( \sum_{d=1}^{N_{TD}} P_{TD}[d, y] * ARPU_{STD} \right) \quad (3.5)$$



**Subject to:**

$$CX[y] + OX[y] \leq TCO_{MAX}[y], \forall y \in Y \quad (3.6)$$

$$CX[y] = \varepsilon_{CX}[y] * \sum_{t \in T} CX[t, y], \forall y \in Y \quad (3.7)$$

$$OX[y] = \varepsilon_{OX}[y] * \sum_{t \in T} OX[t, y], \forall y \in Y \quad (3.8)$$

$$CX[t, y] = \sum_{c \in C} \left( [1 - \phi(t, c, y)] * \sum_{n=1}^{N_c^t} \psi(t, c, y) * [1 + \delta(t, c, y)] * CX_c^t[y] \right) + \sum_{n=1}^{N_{inf}^t} \psi(t, inf, y) * CX_{fiber}^t[y] \quad (3.9)$$

$$OX[t, y] = \sum_{c \in C} \left( [1 - \phi(t, c, y)] * \sum_{n=1}^{N_c^t} P_c^t[y, n] * [1 + \delta(t, c, y)] * OX_c^t[y] \right) \quad (3.10)$$

where:

$$\psi(t, c, y) = P_c^t[y, n] - P_c^t[y - 1, n], \forall n = 1.. N_c^t \quad (3.11)$$

Eqs. (3.1) and (4.2) respectively calculate TCO and ROI for the project lifetime ( $Y$ ). Eq. (4.11) states that TCO is limited in each year. Eq. (3.7) and (3.8) respectively calculate CapEx and OpEx for each year  $y \in Y$  for all transport nodes  $t \in T$ . The factors  $\varepsilon_{CX}[y]$  and  $\varepsilon_{OX}[y]$  represent yearly offered **all-in-one volume discounts** that TSP can benefit for each ordering year ( $y$ ) regardless of ordered quantities.

Eqs. (3.9) and (4.6) respectively calculate the costs of each transport nodes  $t \in T$  by considering CapEx and OpEx of each individual activated component  $c \in C$  inside the transport node  $t \in T$ . The function  $\phi(t, c, y)$  represents the **incremental quantity discount (IQD)** which is the discount TSPs can benefit from high quantity in equipment orders and resulting from the delay of the investment. It is a given function of the estimated quantity ( $\sum_{n=1}^{N_c^t} P_c^t[y, n]$ ) to be ordered for different types of components  $c \in C$ , within transport nodes  $t \in T$  in each year  $y$ . In reality, the function  $\phi$  can be a complex multilevel function (Yoshida, Nishi & Zhang, 2014). The

function  $\psi(t, c, y)$  defined in Eq. (4.7) ensures that TSP pays CapEx calculated in Eq. (3.9) for each component  $c \in C$  only once (when activated). Contrariwise, Eq. (4.6) shows that OpEx is paid every year after activation. The function  $\delta(t, c, y)$  in Eqs. (3.9) and (4.6) represents the yearly increased costs for various components  $c \in C$  due to the incremental approach in deploying the equipment (Khan et al., 2011). In fact, this incremental approach may cause some increased costs related to the installation and configuration of equipment (due to inflation, logistics, manpower, etc) compared to the case that all the equipment (or most of it) is installed at once. The cost of digging and deploying fiber cables is usually shared by users. The cost of a single pair of fibers within the deployed cable is inclusive in the cost of connected ATN interfaces and is modeled by  $CX_{fiber}^t[y]$  in Eq. (3.9). On the other hand, since the costs of ETN interfaces are negligible regarding ETN module and ATN interface, we neglect these costs in our calculations and assume they are inclusive in ETN module costs.

### Control parameters:

In order to control deployment and activation of subracks, modules and interfaces for ATNs and ETNs as defined in the Resource Mapping Diagram (Fig. 3.2). We define following control parameters. A subrack  $s$  is activated in year  $y$ , if and only if at least one of its module  $m$  is activated in this year. If no module is active, the subrack  $s$  is considered idle therefore the subrack cost is not considered in  $TCO$  calculation. Same calculation is applied for the modules, interfaces and traffic demands.

$$P_{sub}^A[s, y] = \begin{cases} 1, & \text{if } \sum_{m=1}^{N_{mod}^A} P_{mod}^A[m, y] \geq 1, \forall m, C_{mod}^A[m] = s \\ 0, & \text{otherwise} \end{cases} \quad (3.12)$$

$$P_{sub}^E[s, y] = \begin{cases} 1, & \text{if } \sum_{m=1}^{N_{mod}^E} P_{mod}^E[m, y] \geq 1, \forall m, C_{mod}^E[m] = s \\ 0, & \text{otherwise} \end{cases} \quad (3.13)$$

$$P_{mod}^A[m, y] = \begin{cases} 1, & \text{if } \sum_{i=1}^{N_{inf}^A} P_{inf}^A[i, y] \geq 1, \forall i, C_{inf}^A[i] = m \\ 0, & \text{otherwise} \end{cases} \quad (3.14)$$

$$P_{mod}^E[m,y] = \begin{cases} 1, & \text{if } \sum_{d=1}^{N_{TD}} P_{TD}[d,y] \geq 1, \forall i, C_{TD}[d] = m \\ 0, & \text{otherwise} \end{cases} \quad (3.15)$$

$$P_{inf}^A[i,y] = \begin{cases} 1, & \text{if } \sum_{s=1}^{N_{sub}^E} P_{sub}^E[s,y] \geq 1, \forall i, C_{sub}^E[s] = i \\ 0, & \text{otherwise} \end{cases} \quad (3.16)$$

$$P_{mod}^E[m,y] - P_{mod}^E[m,y-1] \geq 0, \forall i,y \quad (3.17)$$

$$P_{TD}[d,y] - P_{TD}[d,y-1] \geq 0, \forall d,y \quad (3.18)$$

$$\sum_{y \in Y} P_{TD}[d,y] \geq 1, \forall d \quad (3.19)$$

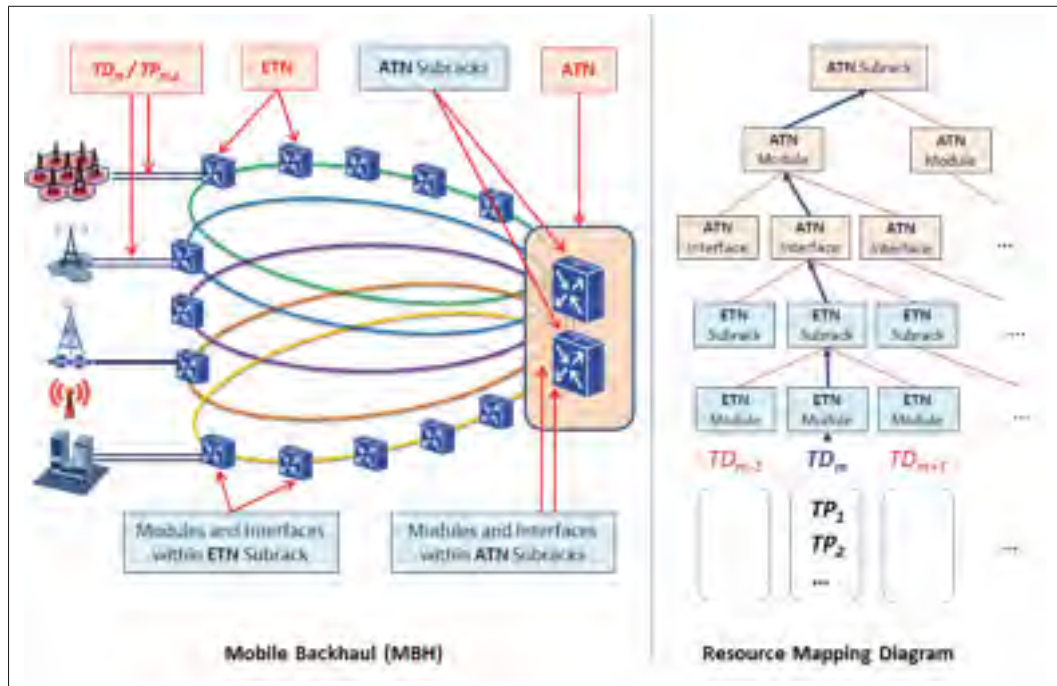

Figure 3.2 MBH resource assignment and mapping diagram

where

$TD_m$  : Traffic Demand for ETN Module  $m$ ,

$TP_{m,p}$  : Traffic Profile  $p$  activated in module  $m$

Eqs. (3.17) and (3.18) state that if an ETN module (or a traffic demand) is activated within year  $y$ , it will remain activate in the following years. This constraint allows network evolution in one direction. We do not consider the exceptional cases where an activate ETN module is deactivated in following years.

### 3.5.3 Proposed TPaaS cost model

TPaaS cost optimization model enhances the BHaaS cost model given in Eqs. (4.1) to (4.9). It adapts the ARPU generated by each STD ( $ARPU_{STD}$ ) according to different tenant service types and related PTP prices ( $ARPU_{PTP}[ptp]$ ):

$$YROI[y] = \sum_{ptp=1}^{N_{PTP}} P_{PTP}[ptp, y] * ARPU_{PTP}[ptp] \forall y \quad (3.20)$$

Subject to:

$$P_{PTP}[p, y] - P_{PTP}[p, y - 1] \geq 0, \forall p, y \quad (3.21)$$

$$\sum_{y \in Y} P_{PTP}[p, y] \geq 1, \forall p \quad (3.22)$$

### 3.5.4 MBH survey algorithm for stochastic aggregation zones

The BHaaS/TPaaS optimization algorithm accepts a matrix of traffic demand as input. Although in reality this matrix is provided by MNOs to the TSP, several demand prediction methods can be used to generate this matrix based on current demand (like time-series, gaussian, etc) (Bayati, Asghari, Nguyen & Cheriet, 2016). The total numbers of subracks ( $N_{sub}^A, N_{sub}^E$ ), modules ( $N_{mod}^A, N_{mod}^E$ ) and interfaces ( $N_{inf}^A$ ) in Table 3.2 are also required as input parameters for BHaaS and TPaaS optimization algorithm. They have to be estimated for each zone because each zone has different small cell densities. A detailed survey is usually done by TSP/MNOs (as part of the MBH network planning phase) in order to estimate the number of backhauling zones  $a \in A$  within the MBH network, the cell density ( $D_a$ ) for each backhauling zone and thus, the number of connection demands ( $CD_a$ ) to connect each mobile tower to the corresponding

ETN. The cell density ( $D_a$ ) is defined by the number and average spacing distance ( $S_a$ ) between adjacent mobile towers collecting end-users traffic. It is depending on the total number of estimated end-users and corresponding average bandwidth consumption in that zone. An example of average spacing distances ( $S_a$ ) between cells is given in Table 3.3. Given the number of ATNs geographically defined within *City*, we design a survey algorithm to define optimal distribution of backhauling zones by minimizing connecting distances between each ETN and its nearest ATN. Traffic demand of each zone is estimated based on calculated area and small cell densities. Algorithm 3.1 is based on a short-distance stochastic geometry model called Voronoi Tessellation algorithm (Baccelli & Giovanidis, 2015). It takes as input an area *City* to be fully covered by 5G small cells and a number of given ATNs. The algorithm returns a list of MBH zones ( $Z$ ) aggregated by each ATN and a list of related calculated areas ( $R$ ). The output of Algorithm 1 ( $R_a$ ) will be combined with ( $S_a$ ) to determine the connection demand ( $CD_a$ ) and also the total traffic demand ( $TTD_a$ ). Table 3.4 presents an example of  $S_a$  definition and  $D_a$  estimation. Once the areas and zones have been identified, the cell density ( $D$ ), connection demand ( $CD$ ) and TDD matrix are calculated as follows:

Table 3.3 Average distance between eNodeBs  
(Kolydakis et al., 2014)

Zone type	Ave. distance $S_a$	Typical value
Very dense urban zones (5G)	$S_a \leq 0.5 \text{ km}$	250 m
Dense urban zones	$0.5 \text{ km} \leq S_a \leq 1 \text{ km}$	750 m
Urban zones	$1 \text{ km} \leq S_a \leq 2.5 \text{ km}$	1750 m
Semi-urban or rural zones	$2.5 \text{ km} \leq S_a$	2500 m

$$D_a = \text{ROUNDUP} \left( \frac{1000}{S_a} \right)^2, \quad \forall a \in A \quad (3.23)$$

$$CD_a = D_a * R_a, \quad \forall a \in A \quad (3.24)$$

$$TTD_a = CD_a * TD_a, \quad \forall a \in A \quad (3.25)$$

Algorithm 3.1 MBH Survey Algorithm: Voronoi diagram and MBH area calculation

```

1 Input:
2  $ATN = \{ATN_a; a \in A\}$  : list of ATNs geographically distributed
3  $C = \{(x_a, y_a); a \in A\}$  : list of coordinates of ATNs
4 # Voronoi : voronoi tessellation returning the zones from the list ATN
5 # Area : Function computing the areas (in Pixels) of each zone given by Voronoi
6 Output:
7  $Z = \{Z_a; a \in A\}$  : list of zones given by Voronoi
8  $R = \{R_a; a \in A\}$  : list of Areas of the zones in Z
9 Begin
10  $Z = \text{Voronoi}(C)$ 
11  $R = \text{Area}(Z)$ 
12 End

```

TTD is estimated based on calculated zone areas and related cell densities. The number of ETN/ATN subracks, modules and interfaces used as input parameters to resolve both BHaaS and TPaaS optimization problems can be estimated accordingly.

### 3.6 Results and Discussion

#### 3.6.1 Traffic demand forecasting using MBH survey algorithm

The architecture of recent cities is often based on Manhattan model where different zones  $Z_a$  have equal area  $R_a^{eq}$  ( $a \in A$ ). We compare connection demand  $CD_a$  calculated by Algorithm 3.1 to connection demand  $CD_a^{eq}$  calculated using Manhattan model where all aggregation zones have an equal and unified area  $R_a^{eq}$  calculated by Eq. (3.26).

$$R_a^{eq} = \frac{\text{Total area of City}}{\text{Total number of aggregation zones}}, \forall a \in A \quad (3.26)$$

We consider as an example the Montreal island (Canada) with 8 geographically distributed ATNs and their coordinates as input. Algorithm 3.1 calculates the optimal zone distribution and returns the list of zones and areas as detailed in Table 3.4 and Fig. 3.3. Table 3.4 presents also cell density  $D_a$  for each ATN zone (Eq. 3.23) and the number of connection demand  $CD_a$

(Eq. 3.24). Small cell densities ( $D_a^{eq} = D_a$ ) remain the same for both calculations. As shown in Table 3.4 and Fig. 3.4, traffic demand can be estimated more precisely using Algorithm 1. For example, our estimation of traffic demand is 63% lower than Manhattan model. In other words, over-provisioning is avoided. total estimated traffic demand for all MBH zones calculated by Algorithm 3.1 is optimized. Algorithm 3.1 performance increased when small cells are denser (e.g. higher than 10 cells per km<sup>2</sup>). Recall that 10 cell/km<sup>2</sup> is the minimum density required by 5G RAN. Thus, MBH resources allocation is more efficient using Algorithm 3.1.

Table 3.4 Number of Towers per Aggregation areas

$Z_a$	$S_a$	$D_a = D_a^{eq}$	$R_a(Km^2)$	$CD_a$	$R_a^{eq}$	$CD_a^{eq}$
$Z_1$	500	4	106,405	426	55,26	221
$Z_2$	300	12	41,755	501	55,26	663
$Z_3$	250	4	165,248	660	55,26	221
$Z_4$	300	12	63,178	758	55,26	663
$Z_5$	200	25	25,39	635	55,26	1382
$Z_6$	100	100	5,155	516	55,26	5526
$Z_7$	150	50	16,908	845	55,26	2763
$Z_8$	150	50	18,018	901	55,26	2763
<b>Total</b>	N.A	N.A	442,057	<b>5242</b>	442.08	<b>14202</b>

### 3.6.2 Comparing TPaas, BHaaS and Traditional TCO model

In the second experiment, we focus on Zone 2 (Saint-Laurent district) with  $CD_{zone2} = 501$ . The target is to plan a future MBH with optimized TCO. We consider the input values defined in Table 3.2 where the number of ETNs in Zone 2 is equal to 512 (= 2\*4\*8\*8) ETNs. The number of ETNs providing 1+1 protected access connection is 1024 (= 512\*2). We assume an average traffic demand of 6 TDs per each connection CD, the TTD for Zone 2 is:  $TTD_{zone2} = CD_{zone2} * TD_{zone2} = 2 * 512 * 6 = 6144$ . So, we use randomly generated traffic demand matrices as input to BHaaS optimization algorithm with TTD increasing from 1024 up to 6144 (= n \* 1024). Three TCO calculation models are considered:

1. Traditional TCO cost model in Section 3.5.1

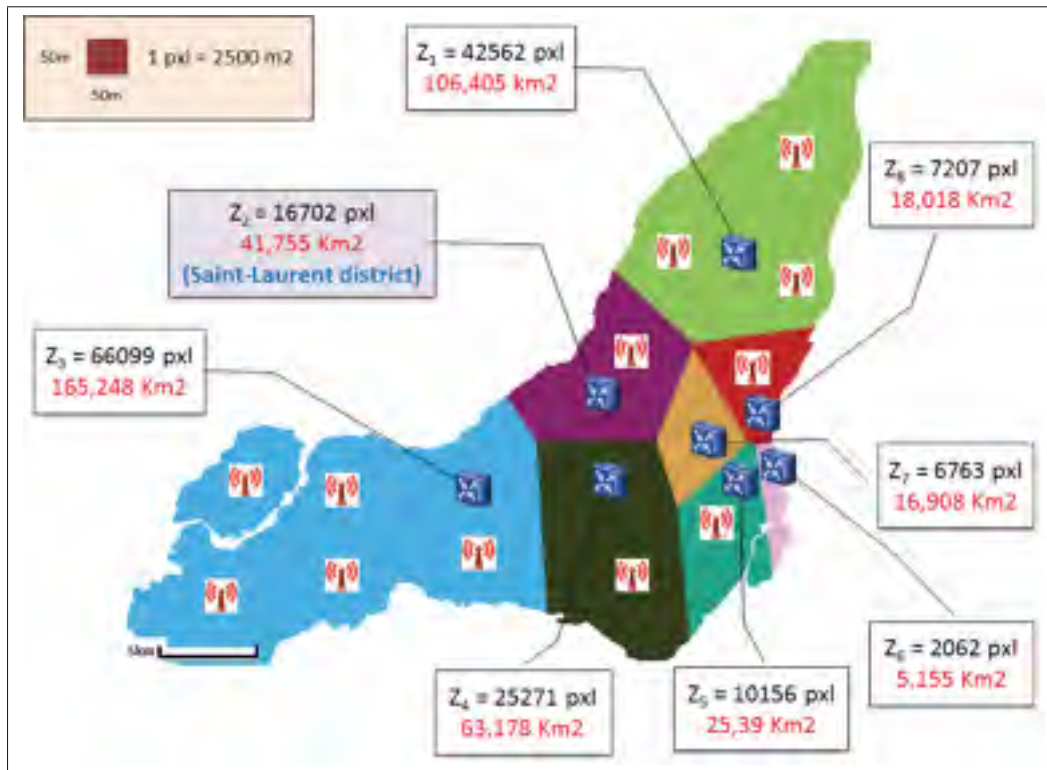

Figure 3.3 Aggregation areas defined by Voronoi Tessellation algorithm (Montreal island use case)

2. BHaaS cost model in Section 3.5.2.
3. TPaaS cost model in Section 3.5.3.

Fig. 3.5. (a) compares cumulative TCO and ROI of three models Traditional, BHaaS and TPaaS regarding the TTD. Since the Traditional TCO estimates the entire project requirements from the first year, it remains constant regardless of the evolution of TTD. On the other hand, BHaaS and TPaaS models are gradually optimizing TCO over years to satisfy TTD. Results show that TSP starts generating profits (the point where ROI exceeds TCO) when TTD reaches 7168 for BHaaS and 5120 for TPaaS. This suggests an advantage of TPaaS over BHaaS and traditional cost models. It is worth noting that Traditional TCO method does not allow to calculate ROI (Haddaji et al., 2017). Fig. 3.5. (b) compares the yearly CapEx and OpEx of the three models when TTD is is large (TTD = 6144). The colors in Fig. 3.5.(b) represent the



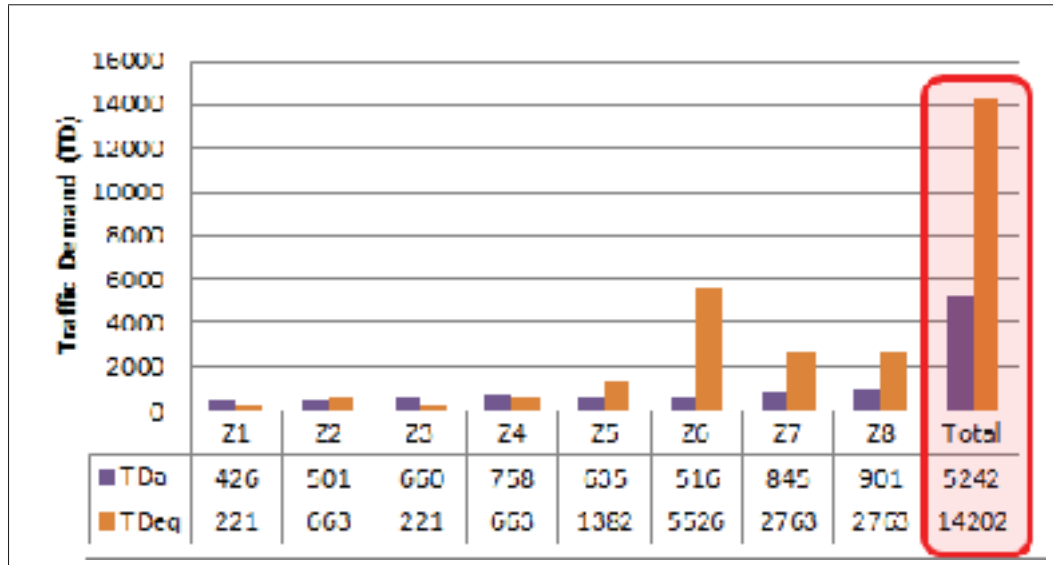

Figure 3.4 Estimated traffic demand for various small cell density zones

Table 3.5 Use case values

Parameter	Use case	Parameter	Use case
$CX_{sub}^A$	400.000 \$	$CX_{mod}^A$	40.000 \$
$CX_{inf}^A = CX_{fiber}^A$	2.000 \$	$CX_{sub}^E$	80.000 \$
$CX_{mod}^E$	20.000 \$	$CX_{inf}^E$	2.000 \$
$OX_{sub}^A$	200.000 \$	$OX_{mod}^A$	20.000 \$
$OX_{inf}^A$	2.000 \$	$OX_{sub}^E$	40.000 \$
$OX_{mod}^E$	10.000 \$	$OX_{inf}^E$	1.000 \$
$N_{sub}^A$	2	$N_{mod}^A$	4
$N_{inf}^A$	8	$N_{sub}^E$	8
$N_{mod}^E$	2	$\epsilon_{CapEx}[y], \epsilon_{OpEx}[y]$	5%
$N_{TD}$	2,4,6,8,10,12	$\phi[t, c, y], \forall(t, c, y)$	$y * 10\%$
$ROI_{TPaaS}[tp]$	$2^{tp-1} * 1.200$ \$	$ROI_{BHaaS}$	4800 \$

different years from 1 to 5 as shown in the right side of the figure. Each year is represented by a different color. Traditional TCO counts all project CapEx immediately since the first year which makes it very high and unaffordable by several TSPs. Since all commissioned resources are considered as active since first activation date, traditional OpEx starts always from the first year. Thus, TSP has to pay licenses, maintenance and warranty fees from the first year

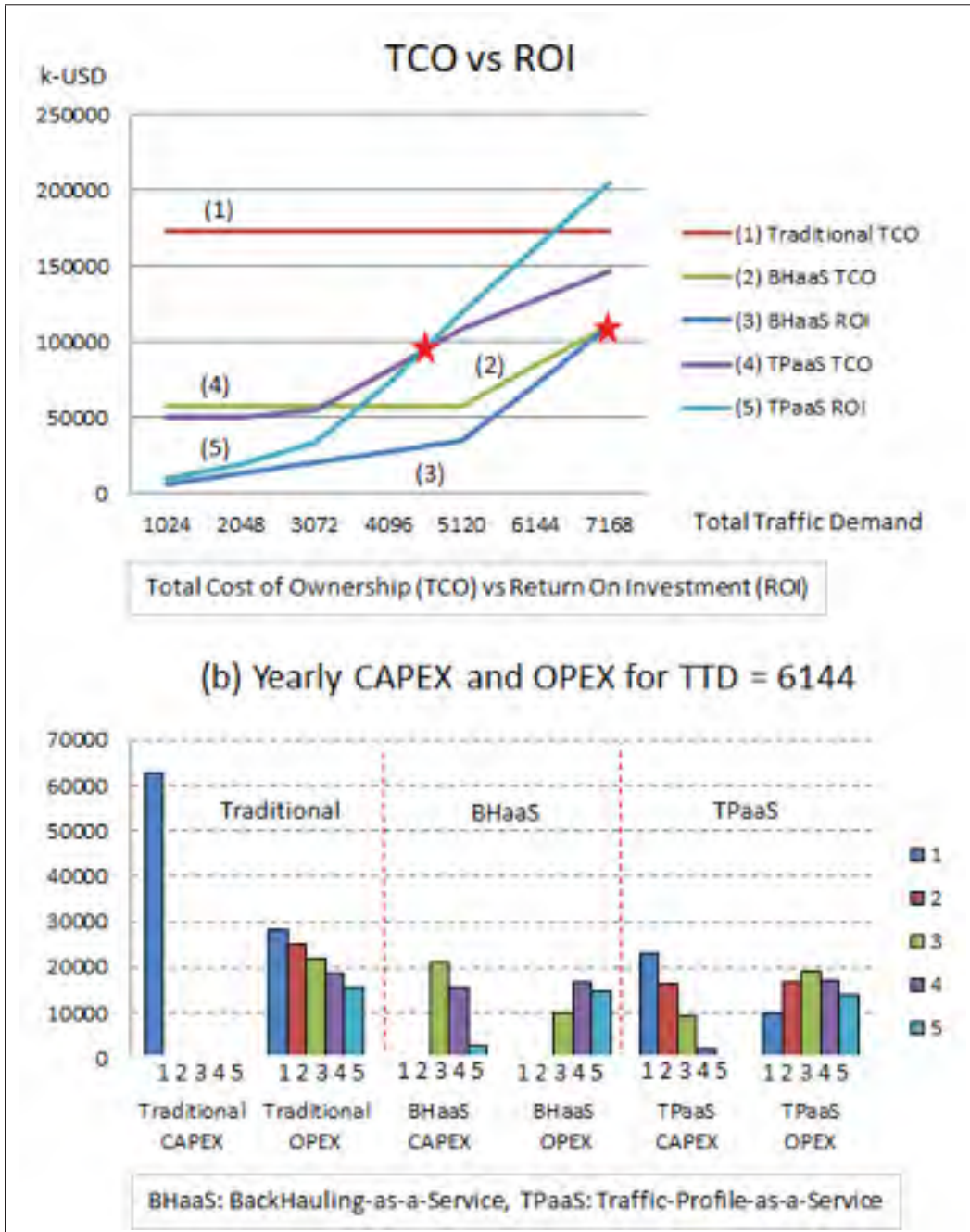

Figure 3.5 Comparing TPaaS, BHaaS and Traditional TCO

while their subracks, modules and interfaces are not yet carrying traffic and not generating any revenue. BHaaS allows TSP to postpone their acquisition of these resources to a future time. The algorithm calculates demand distribution since the first year of the project. However,

it may decide to serve no demand in the first 2 years, as shown in Fig. 3.5. (b) because of no profit. No cost is registered until the moment when the equipment is actually deployed and activated. Installation cost will be added to the total cost of activation. In this case, demand will be afforded in the subsequent years. In other words, the project is not yet launched within this time, and there is no CapEx. In any case, the total demand will be completely afforded when the project ends. On the other hand, TPaaS allows TSP to start the project immediately from the first year and then distribute the costs over the following years. TPaaS CapEx decreases over the years until all TTD is satisfied. Yearly TPaaS OpEx increases slowly to the maximum value in the third year.

### 3.6.3 CapEx and OpEx analysis using TPaaS

We apply our proposed model on two different MBH optical network architecture: PON and Ring and compare CapEx and OpEx for every year (Fig. 3.6). Results in Fig. 3.6 (a) show that for very low TTD, no resource is activated by TPaaS until the fourth year for both technologies. This is explained by the fact that traffic demand is not yet high enough to generate profit. A suboptimal solution could be launching the project since the first year with a smaller number of subracks and modules within ATNs and ETNs. Fig. 3.6 (b) shows that for TDD = 2048, Ring resources remain inactivated for the first three years. However, PON resources are activated in the second year. This is because CapEx and OpEx values are much cheaper for PON than Rings. Thus, the yearly accumulative demand will sooner be enough to afford the cost of PON than of Ring, and hence the project will start getting profits sooner. PON CapEx drops in the third year because OLTs have been allocated in the first year although their components (modules, interfaces, splitters and ONTs) have not been filled. Additional OLTs will be required only in the fourth and fifth years. This is not an over-provisioning of resources because OLT is unsplitable. However, a virtual OLT architecture may help improve resource allocation which is subject to our future work. Fig. 3.6 (c) shows that TDD = 3072 is still too low for Ring to get revenue in the first two years. Fig. 3.6 (d) shows that with TDD = 4096, TPaaS will activate resources and consume CapEx and OpEx in the second year for Ring. Sim-

ilarly to PON in Fig. 3.6 (c), major Ring CapEx is required to purchase ATNs. This cost drops in the third and fourth year because no more ATN is required until the fifth year. OpEx keeps consuming most of the network budget for following years. Fig. 3.6 (e) show that TDD = 5120 is the minimum demand required to kick-off the project since the first year for Ring. Fig. 3.6 (f) shows that for very high (TDD = 6144), CapEx and OpEx of PON and Ring have almost the same behavior. Major CapEx is spent in the first year to acquire ATNs and OLTs, which are not full of components until the fourth year. OpEx is increasing rapidly to reach its peak in the third year where the demand is highest. Then OpEx decreases thanks to yearly discount (input parameter  $\epsilon_{OpEx}[y]$  in Table 3.2, in general 10% per year on all UPL items) offered by solution manufacturers to the TSP for both CapEx and OpEx.

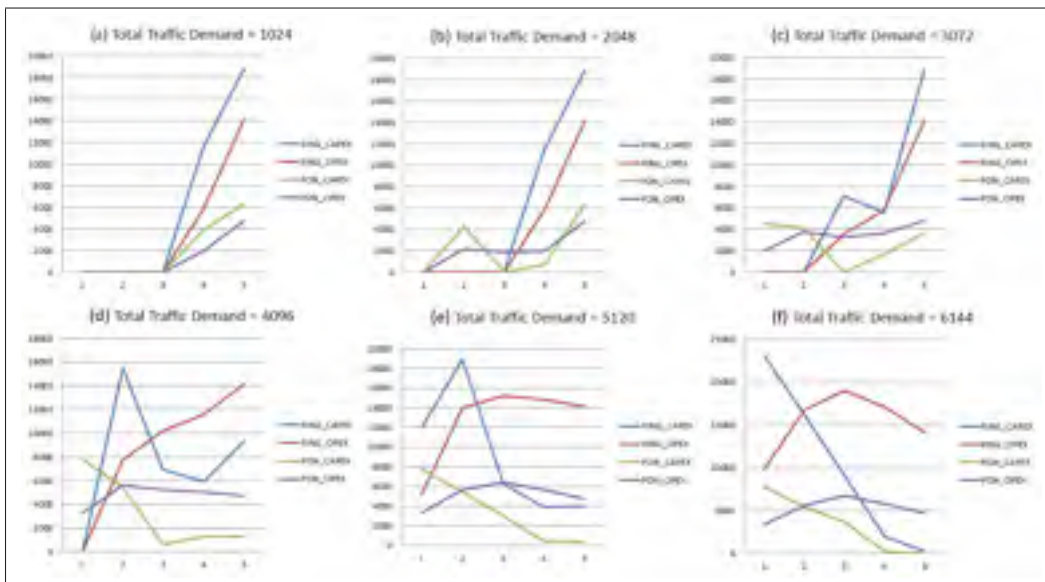

Figure 3.6 CapEx and OpEx yearly evolution for PON and Ring-based networks (using TPaaS)

### 3.6.4 TCO and ROI analysis using TPaaS

An objective of TCO analysis is to determine how soon the project is profitable. This can only be achieved by comparing project costs and revenues. Fig. 3.7 compares both values for PON and Ring.

#### 3.6.4.1 Ring-based MBH networks

Fig. 3.7 (a), (b) and (c) show that for both Ring TCO and ROI are zero in the first three years when  $TTD \leq 3072$  because this demand is still too low. Starting from  $TTD = 4096$  in Fig. 3.7 (d), TPaaS starts activating resources in the second year. ROI increases constantly but the project is not yet profitable since the revenue (ROI line) is still lower than the costs (TCO line). The project gets net profit when  $TTD = 5152$  in Fig. 3.7 (e). ROI is steady when all demand are fully afforded in the fourth year. For higher traffic demand ( $TTD=6144$ ) in Fig. 3.7 (f), the net profit is sooner obtained (in the second year).

#### 3.6.4.2 PON-based MBH networks

Fig. 3.7 (a) shows that  $TTD=1024$  is too low traffic demand to kick-off the project even for PON. TPaaS activates PON resources at earliest in the second year when  $TTD = 2048$  (Fig. 3.7 (b)). Fig. 3.7 (c) shows that for  $TTD=3072$ , PON is not profitable. PON profit starts since the second year for  $TTD=4096$  (Fig. 3.7 (d)), which is earlier than Ring. Fig. 3.7 (e) and (f) show for  $TTD = 5120$  and  $6144$ , ROI is steady when traffic demand is peaked at the third year.

#### 3.6.5 Satisfied traffic demand and activated resources

In this section, we analyze the impact of the TCO optimization using TPaaS on the evolution of the network infrastructure and related traffic engineering. Fig. 3.8. (a), (b) and (c) show respectively the yearly evolution of deployed rings, activated ETNs and Satisfied Traffic Demand (STD) when TDD increases from 1024 to 6144. Each ring is aggregated by two ATN interfaces hosted on two different ATN modules for redundancy reason. Subracks, modules, interfaces and traffic profiles are activated within each ATN and each ETN on yearly basis. Results show that the traffic demand is optimally satisfied over the years according to a non-linear model. The higher demand, the sooner Ring resources are activated (Fig. 3.8. (a)). This may result

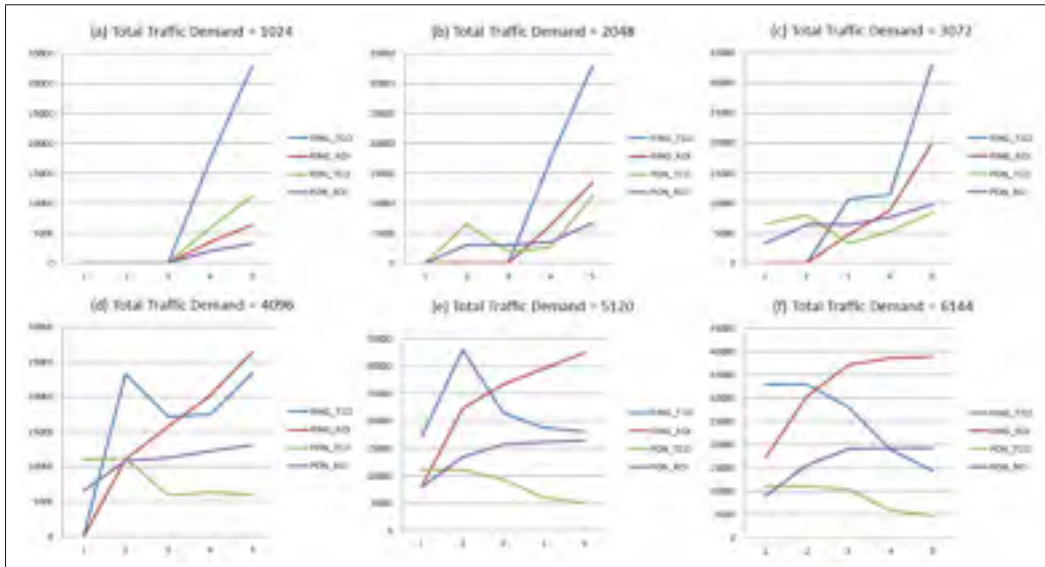

Figure 3.7 TCO and ROI yearly evolution for PON and Ring-based networks (using TPaaS)

in over-provisioning of Rings in the first year of the project. A new ring is activated as soon as a single ETN is active. Thus, Fig. 3.8. (a) shows that, for TDD = 6144, most of Rings are activated since the first year while activation of ETNs (Fig. 3.8. (b)) and STD (Fig. 3.8. (c)) still increase over years.

### 3.6.6 Calculation Runtime for various traffic demands

We used IBM ILOG CPLEX as a solver for our optimization models. Fig. 3.9 shows calculation time on Windows 7 HP machine with i7-4790 CPU @ 3.6 GHz and 8 GB RAM when TTD increases from 1024 to 6144. Execution time is very short for TTD  $\leq$  5120. Starting from TDD = 6144, calculation time increases rapidly. The graph shows also that TPaaS requires a shorter calculation time than BHaaS.

## 3.7 Conclusion

In this paper, we presented an algorithm based on Voronoi Tessellation algorithm to define 5G backhauling zones and estimate more precisely traffic demand and MBH resources. Then, we



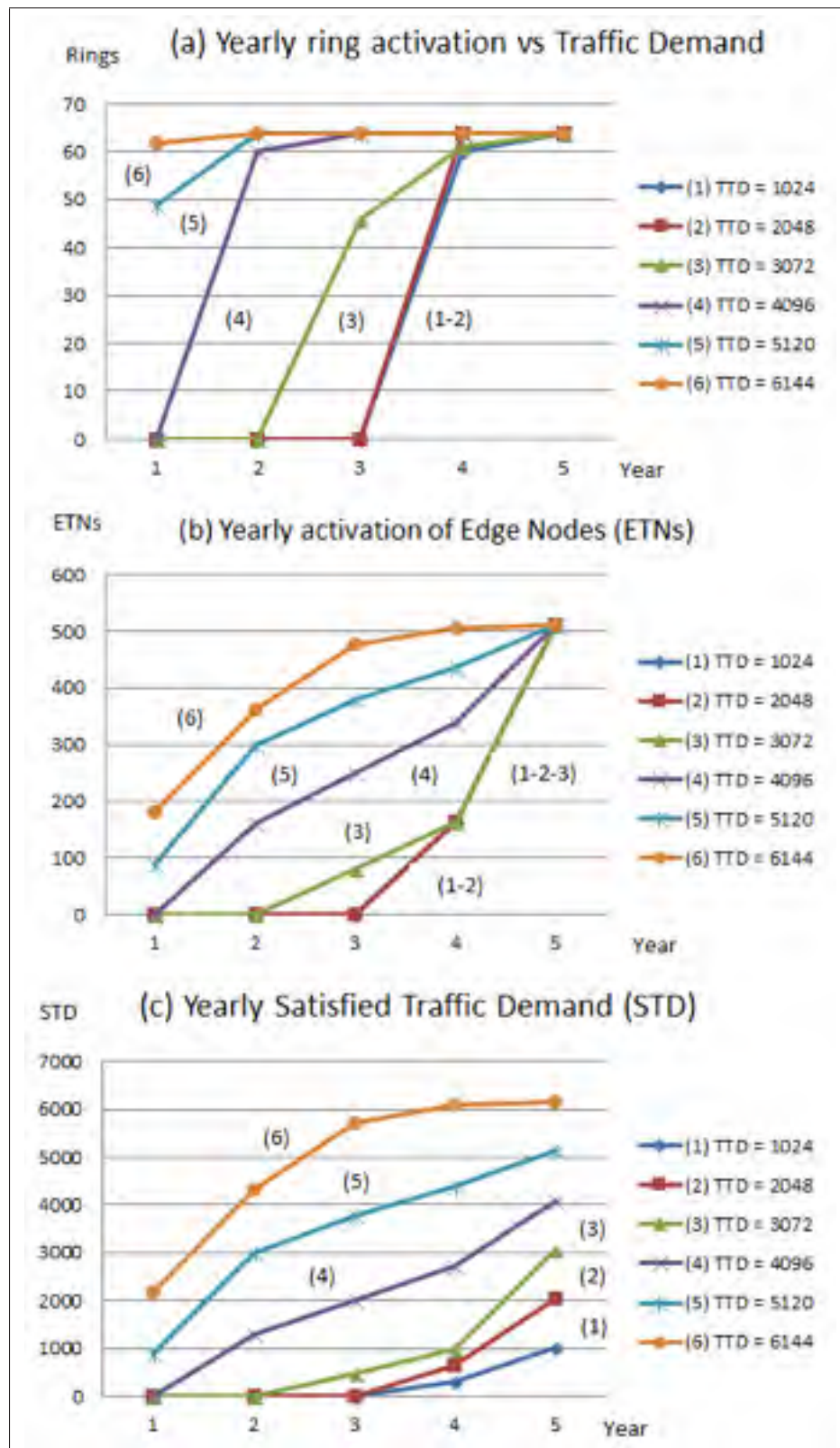

Figure 3.8 Yearly evolution of new activated rings, Edge Nodes and Satisfied Traffic Demand for Ring-based networks (using TPaaS)

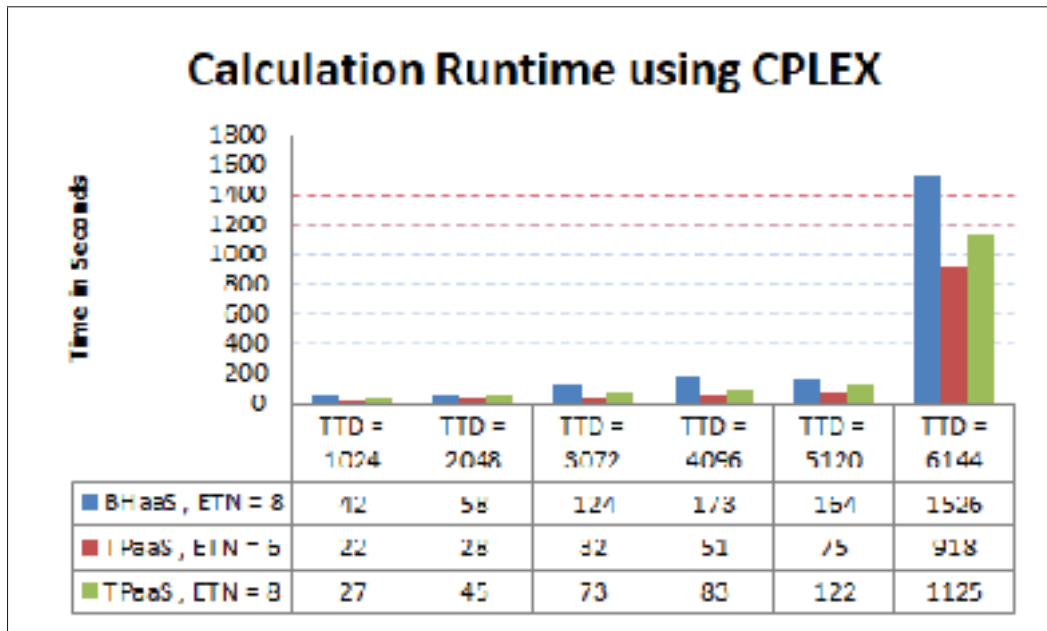

Figure 3.9 Calculation runtime using CPLEX optimization tool for various traffic demands

proposed two new pay-as-you-grow concepts, respectively called BackHauling-as-a-Service (BHaaS) and Traffic-Profile-as-a-Service (TPaaS), to improve the performance and accuracy of network planning and TCO analysis for future 5G MBH networks. The proposed cost models optimize the distribution of CapEx and OpEx of optical MBH over the project years regarding generated revenues. Results shows the efficiency of BHaaS and TPaaS compared with Traditional TCO model in estimating the entire TCO. In particular, results show benefits of using TPaaS cost model to quickly start generating net profit while satisfying traffic demands. It is worth noting that the TCO model proposed in this paper is rather appropriate for "You-pay-only-for-what-you-use" business model. From a traditional TSP perspective, this model may have some shortcomings in losing potential customers. For example, customers with urgent demand may prefer a TSP that accepts initially high investment to immediately afford their demand, thus this later TSP may gain new customers. This issue will be addressed in our future work by an efficient demand prediction which takes into account market behaviors. We intent also to validate the proposed models on SDN/NFV based optical MBH networks and design



a heuristic algorithm to reduce calculation time. A new TCO model for virtual resources will thus be taken into account.

### **3.8 Acknowledgement**

The authors thank NSERC and Ciena for funding the project CRDPJ 461084. This research also receives support from the Canada Research Chair, Tier 1, hold by Mohamed Cheriet. We thank Prof. Rachid Hedjam for his insightful help in defining Voronoi model. The view expressed in this article are those of the authors and do not reflect the official policy of Ciena.



## CHAPTER 4

### TCO PLANNING GAME FOR 5G MULTI-TENANT VIRTUALIZED MOBILE BACKHAUL (V-MBH) NETWORK

Nassim Haddaji<sup>1</sup>, Kim-Khoa Nguyen<sup>2</sup>, Mohamed Cheriet<sup>1</sup>

<sup>1</sup> Department of Automated Production Engineering, École de Technologie Supérieure (ETS), 1100 Notre-Dame Ouest, Montréal, Québec, Canada H3C 1K3

<sup>2</sup> Department of Electrical Engineering, École de Technologie Supérieure (ETS), 1100 Notre-Dame Ouest, Montréal, Québec, Canada H3C 1K3

Article submitted to IEEE OSA, Journal of Lightwave Technology, January 2019

#### 4.1 Abstract

Raising density and ever-increasing traffic demand within future 5G Heterogeneous Networks (HetNets) will result in huge deployment, expansion and operating costs for upcoming Mobile Backhaul (MBH) networks. Multi-tenancy and network slicing based on virtualized resources are promising solutions to satisfy MBH network greediness while reducing related expenditures. Nevertheless, there is no appropriate model that fairly distributes costs over multiple virtual operators, and also optimizes physical resource planning. In this paper, we introduce a new model of 5G multi-tenant MBH costs (CapEx and OpEx). Then, we drive a novel pay-as-you-grow and optimization model called Virtual-Backhaul-as-a-Service (VBaaS) as a planning tool optimizing the Project Profit Margin (PPM) while considering the Total Cost of Ownership (TCO) and the yearly generated Return-on-Investment (ROI). We also formulate an MNO pricing game (MPG) for TCO optimization to calculate the optimal Pareto-Equilibrium pricing strategy for offered Tenant Service Instances (TSI). Finally, we compare CapEx, OpEx, TCO, ROI and PPM for a specific use-case known in the industry as CORD project using Traditional MBH (T-MBH) versus Virtualized MBH (V-MBH) as well as using randomized versus Pareto-Equilibrium pricing strategies. Numerical results show more than three times in-

crease in network profitability using our proposed solutions compared with Traditional MBH (T-MBH).

**Keywords:** 5G, SDN, NFV, CapEx, OpEx, TCO, ROI, Virtualized Mobile BackHaul (V-MBH), Multi-tenancy, Network slicing, Game theory, Bertrand price competition.

## 4.2 Introduction

5G and IoT era are bringing tremendous data explosion with stringent traffic requirements. Large network modernization and expansions are unavoidable. Many Mobile Network Operators (MNO) keep expanding their optical transport network infrastructure to deal with recent challenges of coming 5<sup>th</sup> generation of mobile networks such as capacity, flexibility and costs. These transport networks will definitely cease being profit-making due to massive growth in traffic demand, limited generated revenues as well as raising deployment and operating expenses (Fiorani et al., 2014) and (Khodashenas et al., 2016). One of the emerging solutions for host MNOs is to start leasing their infrastructure as isolated network slices to a number of Mobile Virtual Network Operators (MVNOs) or Tenants who are competing to serve their own end-users using MNO's shared resources. In this context, each MNO is trying to maximize his profits by maximizing his network Return-on-Investment (ROI) while reducing his Total Cost of Ownership (TCO). Traditional Mobile Backhaul (T-MBH) transport networks (Haddaji, Nguyen and Cheriet, 2017) are deploying expensive purpose-built devices consuming tremendous amounts of CapEx and OpEx even before they start generating revenues. Initial high deployment costs make it very hard for most MNOs to kick-off their projects on-time (Sun et al., 2018).

As shown in Fig.4.1, is defined as the access network collecting traffic from several hundreds of high density eNodeB and small cells within 5G HetNets (Heterogeneous Networks) and forwarding it towards the core. An enormous connectivity demand to connect massive 5G RRHs (Remote Radio Head) and MIMO (Multiple-Input Multiple-Output) antenna arrays to centralized Base Band Unit (BBU) pools is driving to a compulsory tremendous budgets to build and

operate future MBH networks. Variants of XG-PON (X-Gigabit Passive Optical Network), MPLS-TP (Multi Protocol Label Switching-Traffic Profile) and DWDM (Dense Wavelength Division Multiplexing) are merging as cost-effective MBH transport technologies (Jaber et al., 2016).

TCO analysis is an important exercise executed by MNOs during planning and design phases in order to control their projects long-term costs and validate their design and investment decisions. The novel concepts of Software-Defined Networks (SDN) (Cho, Lai, Shih & Chao, 2014) and Network Function Virtualization (NFV) (Chen, Rong, Zhang & Kadoch, 2017) offer openness, portability, and efficient resource management in 5G high-density networks. Costly purpose-built middle-boxes in the T-MBH (Fig. 4.1) are being replaced by commodity hardware devices controlled by centralized Virtual Network Functions (VNF) running in compute instances (such as Virtual Machines (VM) or micro-service containers). These compute instances are deployed on top of large-scale commodity servers and creating the intelligence part of the Virtual MBH (V-MBH) networks (Fig. 4.2). It results in new challenges for TCO calculation, because V-MBH are shared among various mobile network RRH or base stations (Jaber et al., 2016). According to (Chen, Rong, Zhang & Kadoch, 2017), only radio functionalities of the Virtual eNodeB (VeNB) are located in the RRH. Most of processing and computing intelligence (like spatial domain management, null-space calculation for massive MIMO coordination, etc) is moved to high-performance cloud BBU pools to achieve higher scalability and flexibility. Reliable, high capacity and low latency MBH is therefore required to collect traffic from RRH and forward it to the BBU pool.

In this paper, we investigate TCO planning for V-MBH based on the so-called Central-Office-Re-architected-as-a-Datacenter (CORD) (Peterson et al., 2016) architecture. Relying on the agile SDN/NFV architecture, CORD offers flexible provisioning and end-to-end control of multi-tenant connectivity (Access-as-a-Service) and elastic cloud services (Software-as-a-Service) for residential (R-CORD), enterprise (E-CORD), and mobile (M-CORD) network applications. We focus on R-CORD use-case which is based on commodity ONTs and low-cost slide-in I/O

access blades controlled by Virtual OLT (vOLT) software. The vOLT software is running in commodity servers connected by several leaf-and-spine switching fabric (Fig.4.2).

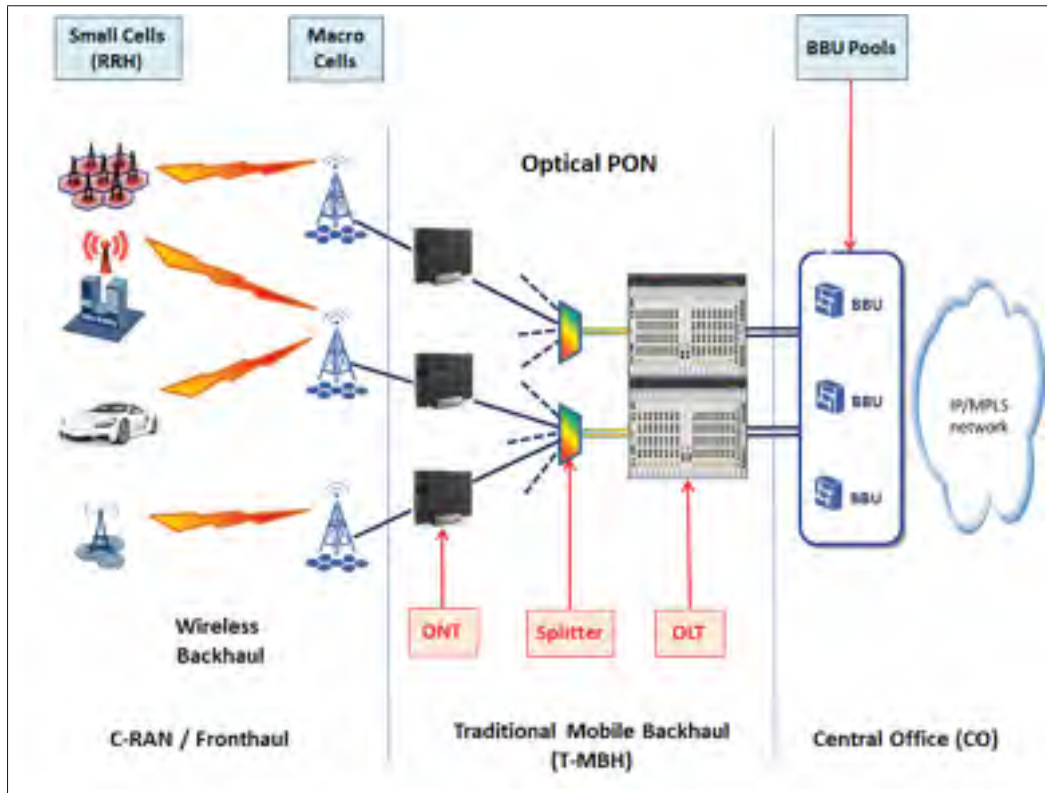

Figure 4.1 Traditional Mobile BackHaul (T-MBH) network

In this work, we extend TPaaS cost model discussed in (Haddaji, Bayati, Nguyen and Cheriet, 2018) to software-based multi-tenant V-MBH. In fact, future optical MBH networks are based on software components running on commodity devices to be able to control flat revenue margins in coming 5G high density HetNets (Peterson et al., 2016). Planning of such raising V-MBH networks shall also be optimized on yearly resource activation and related revenue generation. Network expenditures need to be scattered over the planned project runtime span in order to help MNOs expand their networks at suitable paces.

Main contributions of this paper are as follows:

1. **TCO models for V-MBH:** We propose a detailed costs formulation for SDN/NFV based 5G multi-tenant V-MBH in order for MNOs to reduce network costs and dynamically scale their infrastructure as per the pace of raising traffic demand.
2. **Virtual-Backhaul-as-a-Service (VBaaS):** We introduce a novel pay-as-you-grow and service-aware optimization model called *Virtual-Backhaul-as-a-Service (VBaaS)* as a planning tool to plan yearly activation of required Tenant Service Instances (TSIs) and execution of VNFs while optimizing the PPM (TCO versus ROI) for future V-MBH projects.
3. **MNO Pricing Game (MPG) for TCO optimization:** We model the interaction between resource activation and price strategies of multiple competing MNOs by Bertrand price competition game, and then we calculate the optimal Pareto-Equilibrium prices for TSIs to further optimize the PPM and to define to which extent MNO shall invest to improve its offered SLAs.

The remainder of this paper is as follows. Section 4.3 reviews related work. In Section 4.4.1.1, we propose a CapEx and OpEx cost model for 5G multi-tenant V-MBH optical transport networks. Then, we introduce a novel pay-as-you-grow, and a service-aware concept called *Virtual backhaul-as-a-Service (VBaaS)* to optimize PPM. We also define an MNO Pricing Game (MPG) to calculate the optimal equilibrium price. In Section 4.5, we compare results of optimized CapEx, OpEx, TCO, ROI and PPM for T-MBH versus V-MBH and using randomized prices versus Bertrand Equilibrium price. Section 4.6 concludes the paper.

### 4.3 Related Work

Offered SLAs are depending on network capacity and available QoS. The compromise between optimal investment costs and decided service pricing strategy is a challenging planning question for MNOs. In particular, several efforts were carried out in previous works to optimize infrastructure resources and drop costs of coming 5G optical backhaul networks. However, most of the focus was offered to the technical issues until some recent studies that has been

Table 4.1 Costs for Hardware and Software components in T-MBH and V-MBH networks

<b>Host MNO</b>	<b>Fully owned Traditional MBH</b>	<b>Fully owned Virtualized MBH</b>
$CapEx^{HW}$	Traditional GPON CPEs OLT racks and basic hardware Traffic modules, switching fabric Power and management modules Installation / deployment fees	Commodity GPON CPEs Access racks and I/O blades Commodity servers Spine and leaf switches Installation / deployment fees
$CapEx^{SW}$	Fully loaded equipment software	<b>VNF deployment costs</b> <b>VNFs one-time license fees</b>
$OpEx^{HW}$	Spare parts and warranty Right-to-Use and license keys	Spare parts and warranty Right-to-Use and license keys
$OpEx^{SW}$	Network managed services System maintenance costs	VNF maintenance costs Software and certificate update
<b>MVNO / Tenant</b>	Renting servers in V-MBH	Renting VNF-as-a-Service
$CapEx^{HW}$	Commodity GPON CPEs Access racks and I/O blades	Commodity GPON CPEs Access racks and I/O blades
$CapEx^{SW}$	VNF deployment costs VNFs one-time license fees	
$OpEx^{HW}$	Servers annual rental fees	
$OpEx^{SW}$	VNF maintenance costs Cloudware fees	VNFs annual rental fees

carried out on the economic aspects in optimizing MBH networks. In this section, we review various related works and their contributions.

(Zefreh, Tizghadam, Leon-Garcia, Elbiaze & Miron, 2014) introduces a Mixed Linear Integer Program (MILP) optimization algorithm to generate - while minimizing CapEx - a detailed Bill of Materials (BoM) and an optimum network design in transport networks. The model takes as input several parameters such as i) network topology, ii) traffic demand matrix and iii) prices of various network elements/cards/modules for multi-chassis routers with multi-rate line cards. German and US backbone sample networks are used as examples to evaluate the performance of proposed heuristic method and compare generated BoM with realistic ones.



(Mahloo, Monti, Chen & Wosinska, 2014) presents a comprehensive cost modeling methodology to assess TCO of MBH networks including both microwave and fiber technology options. The authors introduce a first complete assessment of the entire TCO and the impact of a given backhaul technology on a HetNet deployment using small cells. Detailed CapEx and OpEx breakdown is proposed and can be used for different backhaul technologies and architectures. The model is applied on the MBH of a dense urban area over a 20-year time period. Results show impact of MBH technology and HetNets density on MBH TCO. Fiber remains most promising technology for backhaul for dense HetNets thanks to its scalability and high capacity.

(Knoll, 2015) defines a detailed techno-economic model for LTE networks including a novel comprehensive TCO analysis for real and virtualized network components. Various project life-cycle phases are considered in TCO calculation. CapEx and OpEx cost models take into account various SDN/NFV based scenarios: i) equipment can be owned or rented, ii) real or virtual devices, iii) globally or individually, and iv) VNFs running on top of Virtual Machines (VMs) can be outsourced/rented based on a VNF-as-a-Service (VNFaaS) model. The model development and result analysis are done using the software “Strategic Telecoms Evaluation Model (STEM)” over a 5 years runtime. Resulting CapEx and OpEx cost analysis investigates the profitability of a fully virtualized versus a traditional mobile network. Yearly accumulated TCO results are summed up over the run period for fully owned or rented data-center resources. Nevertheless, cost values are based on assumptions and market forecasts with around 20% uncertainty. Table 4.1 presents these various scenarios that will be considered in our evaluation study in Section 4.5.

(Bouras, Ntarzanos & Papazois, 2016) presents a techno-economic analysis for integration of recent technologies such as SDN, NFV and Cloud Computing in 5G mobile networks. CapEx and OpEx are compared between traditional and proposed network architecture to estimate TCO based on number of deployed Base Station (BS) sites in Sweden. First, the model is applied on traditional BS deployment with 10, 20, 30, 50, 80, and 100 physical BSs. Second, it is applied on the proposed network architecture where up to 6 Virtual BSs (vBS) are deployed on

one physical Software-based BS (SBS). Results show that virtual network architecture offers a significant TCO reduction compared with traditional deployments (OpEx, CapEx, and thus TCO are reduced by 60+% in comparison with traditional network)

(Yu & Kim, 2014) presents a game theoretic compromise of quality versus price competition among MNOs and analyse price dynamics in a real world. An optimization problem is defined based on a two-stage competition model combining Cournot (quality and investment) and Bertrand (price and revenue) competition games. The outcome is an equilibrium point between quality-of-service (QoS) offered by MNO networks and competing service prices driven by end-users. The authors emphasize on the importance of defining *"how much of the network capacity should be provisioned and how high the service price should be"* (Yu & Kim, 2014). The authors recommend a simple regulation rule that guarantees an equilibrium point of price levels (Pareto-optimal price) to drive effective resource planning and optimum network investments.

(Haddaji et al., 2018) introduces a novel network planning and TCO analysis method, called BackHauling-as-a-Service (BHaaS) based on "You-pay-only-for-what-you-use" approach. BHaaS maximizes the project profit margin ( $PPM = ROI - TCO$ ) by introducing a detailed model for invested TCO and generated ROI. TCO calculation is proportional to yearly satisfied traffic demands and activated MBH resources. ROI calculation is proportional to MNO wholesale prices and yearly generated ARPUs. Unlike TCO calculation models where costs are globally calculated for entire period of time, TCO and ROI calculation in BHaaS are more precise since they are loyal to yearly network evolution. The performance of this proposed method is further enhanced by a more service-aware method named Traffic-Profile-as-a-Service (TPaaS) that considers also different types and costs of each activated traffic profiles. The resolution of the ILP (Integer Linear Programming) optimization problem shows the advantage of BHaaS and TPaaS to control and enhance the PPM by 22% compared to traditional cost calculation model. Nevertheless, BHaaS and TPaaS are focusing only on hardware based traditional MBH solutions based on purpose-built devices. Also, the competitions of MNOs resulting from the

new virtual resource renting mechanism has not been taken into account.

With a target to reduce TCO of optical MBH networks, prior work focused on optimizing the number of planned network elements and related costs of their specific technologies. Existing TCO analysis do not pay attention to Service Level Agreements (SLA) between MNOs and their customers. Cost models proposed in prior work do not consider Average-Revenue-Per-User (ARPU) values generated by satisfying each connected Tenant Service Instances (TSI) and the total ROI generated by yearly activated network services. Moreover, to the best of our knowledge, no prior work has considered the TCO planning and pricing games for SDN/NFV based virtualized MBH networks. In this paper, we extend BHaaS and TPaaS models to consider the raising software-based network virtualization technologies such as SDN and NFV. Thus, we propose the *Virtual-backhaul-as-a-Service (VBaaS)* model to optimize the PPM for multi-tenant V-MBH. We also apply game theoretic models to define the best wholesale pricing strategy for MNOs to optimize related ARPUs and also the yearly generated ROI.

## 4.4 System Model

### 4.4.1 VBaaS TCO Optimization

#### 4.4.1.1 Framework definition

Given a number of macro and small cells from various Tenants (MVNOs) or Tower  $t \in T$ , (see Fig. 4.2 and Table 4.2) within a new 5G high-density HetNet. Consider a host MNO who is planning to build and lease slices of his MBH transport network to these MVNOs. Total number of required TSIs to connect the towers in the RAN is globally forecasted by MNOs based on the number of his customers (MVNOs) and their connectivity requirements. A randomly generated matrix of Tenant Service Instances  $TSI[t, i], \forall (t, i) \in T \cap I$  is provided as input where related traffic needs to be backhauled from each Tenants/Tower  $t \in T$  to the core network. The target is to plan, maximize and validate the project profitability for deploying and operating a

new multi-tenant V-MBH optical network over the project runtime  $Y$ . Optimal quantities for resource deployment and activation are calculated prior to the network installation phase. TCO is calculated by adding deployment costs (CapEx) to operating costs (OpEx) for the number of years  $Y$ . For most MNO strategic planning exercises, TCO analysis are carried out over five (5) years in order to decide whether the project is profitable or not (Khan et al., 2011)

Unlike Traditional MBH (T-MBH) projects where TCO analysis are based on expensive hardware infrastructure (purpose-built access and aggregation devices), MNOs are trying to drop MBH costs thanks to software components running on cost-effective commodity ONTs / CPEs  $c \in C$ , universal I/O access Blades  $b \in B$  and commodity Servers  $s \in S$ . Network functions are moved to VNFs instantiated in compute instances  $v \in V$  such as VMs (Virtual Machines), Containers and Containers-in-VMs. Compute instances are hosted in commodity servers  $s \in S$  organized into a rackable unit called a POD (Point-of-Delivery). Several PODs with different configurations are required to build all-purpose, multi-tenant and scalable data centers. Various components of each POD such as commodity servers and access blades are connected via a leaf-spine switch fabric (Fig. 4.2). Each commodity server  $s \in S$  is usually connected to two separate Leaf switches  $l \in L$  for redundancy. Each leaf switch  $l \in L$  is connected to ALL available spine switches  $p \in P$  in the higher layer for maximum redundancy as shown in Fig. 4.2. Leaf switches are not connected to leaf switches. Same, spine switches are not connected to spine switches. Table 4.2 summarizes the various symbols and related meanings. Fig. 4.2 summarizes R-CORD architecture using the spine-leaf switching fabric and presents the physical and virtual resource mapping tree to satisfy requested TSIs. It shows the virtualized OLTs in V-MBH which are split into GPON I/O access blades (installed inside access racks) and vOLT software package running on top of a number  $v \in V$  of compute instances (inside commodity servers).

On top of this virtual infrastructure, the use of recent concepts such as multi-tenancy and network slicing is added to the complexity of the TCO problem. Payments for constructing and operating new networks are avoided / delayed by maximizing infrastructure sharing and resource utilization among multiple tenants. In particular, an isolated set of 5G physical and

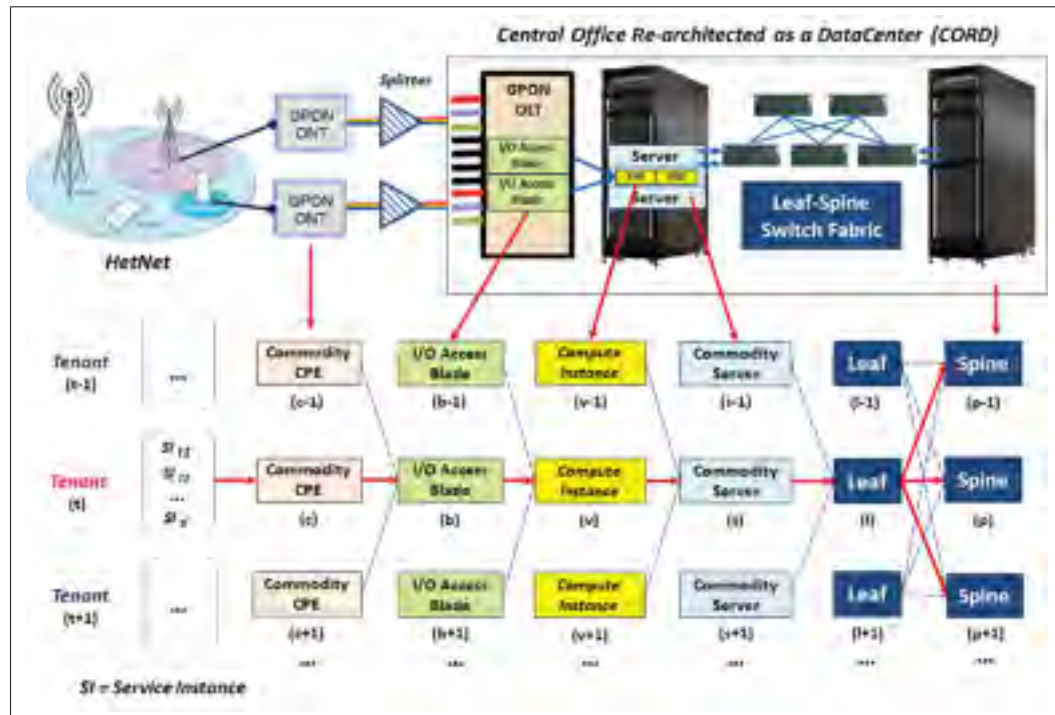

Figure 4.2 Resource Mapping Tree in virtualized optical backhaul networks

virtual transport resources is dynamically assigned upon demand as a dedicated network slice to each tenant. Therefore, a smart planning and efficient cost analysis for data center resources is required to optimize new project TCO and enhance V-MBH profitability and scalability. Infrastructure resources should not be switched-on in V-MBH network unless corresponding service is active, carrying traffic and generating revenue. Forthcoming 5G V-MBH networks should move from "always-on" dummy pipes to "always-available" and "service-aware" resource commissioning. We define a 3-stage planning and optimization model to optimize the MNO project PPM:

- **Stage I:** Host MNO estimates the total demand of required TSIs to satisfy all MVNOs within a certain period of time. This demand is usually forecasted by MNO using a survey exercise and is provided as a randomised input matrix in our model calculation.

- **Stage II:** TSI wholesale prices  $P_w$  offered by host MNO to its tenants is calculated using game theory based on competition best response pricing strategy as discussed in Section 4.4.2.
- **Stage III:** PPM is calculated by optimizing costs versus revenues for deploying and operating V-MBH during the project runtime. Revenue calculation in this stage uses the TSI prices calculated in Stage II. Detailed optimization problem is defined in Section 4.4.1.1.

#### 4.4.1.2 Assumptions

We assume all hosting servers contain a fix number of compute instances (VMs, containers, etc) with comparable memory resources and CPU (Central Processing Unit) requirements. Each commodity server  $s \in S$  is connected to only one Leaf switches  $l \in L$  with no redundancy. A server is shutdown when there is no compute instances running. Network bandwidth is always affordable since we use multiple 100G connectivity cables to connect application servers to leaf switches and leaf-to-spine switches. A new leaf switch is added to the networking fabric when no more leaf ports are available to connect application servers. The number of spine switches depends on the number of leaf switches and is defined by a given leaf-to-spine ratio. ONTs / CPEs are connected to I/O access blades using 10G-PON technology. A new access blade is added to OLT racks when no more PON ports are available to connect remote ONTs. The objective is to activate the minimal number of devices and software components (ONTs, access blades, compute instances, servers, leaf and spine switches) to afford traffic demand. In other words, we try to delay as long as possible the activation of each of above hardware and software components until the moment when revenue is highest.

#### 4.4.1.3 Problem Formulation

The proposed VBaaS model distributes the deployment and activation of software and hardware components over the number of years  $Y$  to maximize the project PPM. Deployment and

Table 4.2 Symbol Notation

Symbol	Meaning
Y	Number of years in project runtime (usually $Y = 5$ )
T	Set of Tenants served by the multi-tenant network
I	Set of Tenant Service Instances (TSI) to be connected
C, B	Respectively sets of CPEs and access blades
V	Set of compute instances, $V = \{vm^{owned}, vm^{rented}\}$
S, L, P	Respectively sets of servers, leaves and spines
H	Set of all hardware types within V-MBH, $H = \{CPE, Blade, Server^{owned}, Server^{rented}, Leaf, Spine\}$

Table 4.3 Problem parameters

Name	Description
$D^{TSI}[y, t, i]$	Yearly satisfied Demand of TSIs for all tenants
$ARPU^{TSI}[y, t, i]$	Generated revenue by yearly satisfied TSIs
$\delta_{CX}[y], \delta_{OX}[y]$	Yearly discount for CapEx and OpEx
$D[h, n, y], D[v, n, y]$	Served Demand for element $h \in H$ or $v \in V$
$CX[h], OX[h]$	CapEx and OpEx of Hardware $h \in H$
$CX[v], OX[v]$	CapEx and OpEx of Compute Instance $v \in V$
$\alpha$	Leaf to spine ratio
$Y = 5$	Project runtime
$p_{max}$	Max. number of spine switches
$l_{max}$	Max. leaf switches per spine switch
$s_{max}$	Max. servers per leaf switch
$v_{max}$	Max. compute instances per server
$b_{max}$	Max. blades per compute instance
$c_{max}$	Max. CPEs per access blade
$i_{max}$	Number of TSIs per CPE
$k[y, t, i]$	Normalized network capacity for TSI $i \in I$
$Pw[y, t, i]$	Normalized wholesale price for TSI $i \in I$

operating costs related to each component are considered in TCO calculation only when they are selected by VBaaS for activation. Only revenue generating devices and related compute instances are planned by VBaaS for immediate activation while the deployment of remaining components will be delayed for a later year. VBaaS model is defined as a MILP optimization problem (named TCO\_OPT problem) whose objective function defined in Eq. (4.1) is to optimize PPM of the V-MBH project which is the difference between consumed TCO ver-



sus generated ROI. Fig. 4.2 details the resource mapping tree in virtualized optical backhaul networks. Table 4.3 presents the problem parameters and decision variables.

$$\text{maximize } PPM[Y] = ROI^{TSI}[Y] - TCO^{VB}[Y] \quad (4.1)$$

**s.t.**

$$ROI^{TSI}[Y] = \sum_{y \in Y} \sum_{t \in T} \sum_{i \in I} ARPUS^{TSI}[y, t, i] \quad (4.2)$$

$$ARPUS^{TSI}[y, t, i] = \frac{Pw[y, t, i] * D^{TSI}[y, t, i]}{|I_{y, t, i}|} \quad (4.3)$$

$$TCO^{VB}[Y] = \sum_{y \in Y} (\delta_{CX}[y] * CX[y] + \delta_{OX}[y] * OX[y]) \quad (4.4)$$

$$CX[y] = \sum_{m \in H \cup V} \left( [1 - \phi(m, y)] \sum_{n=1}^{N[m]} \psi[m, n, y] * CX[m, y] \right) \quad (4.5)$$

$$OX[y] = \sum_{m \in H \cup V} \left( [1 - \phi(m, y)] \sum_{n=1}^{N[m]} D[m, n, y] * OX[m, y] \right) \quad (4.6)$$

$$\psi(m, n, y) = D[m, n, y] - D[m, n, y - 1], \forall n = 1..N[m] \quad (4.7)$$

$$D_j[n, y] - D_j[n, y - 1] \geq 0, \forall j \geq 1, \forall n \in G_j \quad (4.8)$$

$$\sum_{y \in Y} D_{tsi}[i, y] \geq 1, \forall i \in I \quad (4.9)$$

$$\frac{\sum_{n=1}^{N[l]} D[l, n, y]}{\sum_{n=1}^{N[s]} D[s, n, y]} = \alpha, \forall y \in Y \quad (4.10)$$

$$CX[y] + OX[y] \leq TCO_{MAX}[y], \forall y \in Y \quad (4.11)$$

Eq. (4.2) calculates the total ROI generated by adding ARPUs of satisfied TSIs  $i \in I$  of all tenants  $t \in T$  during the project runtime  $Y$ . Eq. (4.3) calculates the ARPU as defined in (Sun et al., 2018) for each tenant on yearly basis where  $Pw[y, t, i]$  is the Wholesale price of the offered TSI service,  $D^{TSI}[y, t, i]$  represents the yearly demand of activated TSIs and  $|I_{y, t, i}|$  represents the cardinality (total number of TSIs) of a group of TSIs  $i \in I$  for a tenant  $t \in T$  in year  $y \in Y$ . Eq.



(4.4) calculates the TCO for V-MBH network by considering the yearly evolution of CapEx and OpEx during the project runtime  $Y$ . A yearly discount  $\delta$  is usually offered and considered in our model. Eq. (4.5) and (4.6) respectively calculate CapEx and OpEx for Hardware and Software network components in V-MBH by considering the different scenarios defined in Table 4.1. The function  $\phi(m, y)$  represents the incremental quantity discount (IQD) offered to MNOs for high ordered quantities (Haddaji et al., 2018). Eq. (4.7) shows that CapEx costs for any network component are calculated only once i.e. only during the year when activated. On the other hand, OpEx costs are counted every year since activation date as shown in Eq. (4.6). Eq. (4.8) imposes that the network evolve in one-direction by maintaining deployed CPEs and related TSIs active for coming years during the project runtime. We assume that an activated service instance in year  $y$  will not be disconnected in coming years within the project runtime  $Y$ . Eq. (4.9) assures that there is always initial service instances  $i \in I$  requested from at least one tenant  $t \in T$ . The coefficient  $\alpha$  in Eq. (4.10) is a given leaf-to-spine ratio that defines the required number of spine switches. Eq. (4.11) shows that yearly project TCO is limited by a maximum allowed budget for each year  $y \in Y$ .

#### 4.4.1.4 Control parameters

The main contribution of proposed VBaaS method is to control yearly deployment and activation of hardware and software elements within V-MBH following the so-called "You-pay-only-for-what-you-use" approach. We define two "order" sets, the group  $G$  for network component and the group  $D$  for related activation demand.

$$G = (G_1, G_2, G_3, G_4, G_5, G_6, G_7) = (I, C, B, V, S, L, P)$$

$$D = (D_1, D_2, D_3, D_4, D_5, D_6, D_7) =$$

$$(D_{tsi}, D_{cpe}, D_{bld}, D_{vm}, D_{srv}, D_{leaf}, D_{spine})$$

$\forall y \in Y; \forall j \geq 2; \forall n \in G_j :$

$$D_j(n,y) = \chi \left\{ \sum_{m \in G_{j-1}; B(m)=n} D_{j-1}(m,y) \geq 1 \right\} \quad (4.12)$$

Eq. (4.12) assures that costs of any idle (not activated) network component  $n \in G_j$  where  $j = 1..7$  are excluded from the cost calculation until related offered service is provisioned and started generating revenue. The functions in Eq. (4.12) are defined as follows:

- $\chi \{ A \}$  is the Indicator Function (also called Characteristic Function) that takes the value 1 if the condition A is satisfied and the value 0 otherwise.
- $D_j(n,y)$  is the Demand Function of deployed and activated network component n within  $G_j$  in year y.
- $B(m) = n$  is a Binding Function that attaches the network component  $m \in G_{j-1}$  to the next level component  $n \in G_j$  as per the resource mapping tree presented in Fig. 4.2 (e.g. the function binds a number of compute instance  $v \in V$  to a certain commodity server  $s \in S$ , etc)

In VBaas, a leaf switch  $l \in L$  is counted, if and only if, at least one server is connected to it. The number of spine switches is defines by the number of leaf switches and the leaf-to-spine ratio  $\alpha$ . Moreover, if no compute instances are executed in a server  $s \in S$ , then the server is considered as idle and therefore it is not considered in VBaaS cost model. Same applies for access blades and commodity CPEs. Costs of a compute instance are excluded from the total cost if it is not serving any access blades in year  $Y$ . An access blade  $b \in B$  is idle if no CPE is connected to it and it is forwarding no traffic. Finally, a CPE  $c \in C$  is included, if and only if, it is serving / satisfying a TSI  $i \in I$  for a tenant  $t \in T$ .

In Section 4.4.2, we use Game Theory to further enhance VBaaS model and V-MBH network profitability by optimizing the wholesale price  $Pw[y,t,i]$  in Eq. (4.3). This price is used to

calculate ARPUs and then ROI as depicted in Eq. (4.2). It can be optimized by defining the MNO best pricing strategy in a competing oligopoly market and calculating the Pareto-equilibrium price to be used to lease the TSIs.

#### **4.4.2 MNO Pricing Game (MPG)**

##### **4.4.2.1 Problem statement**

The problem of MNOs leasing isolated slices of their networks to several tenants (MVNOs) can be viewed as a non-cooperative transportation game (Stein et al., 2018). MNOs have different price strategies and try always to minimize their investment costs and maximize their profits (payoffs) as rational players in the price competition game. Each MNO will always have incentives to undercut his TSI prices given the price strategies of his competitors. This continuous changing in payoffs will drive prices down to low marginal costs which may affect the industry profits and limit offered services in the market. This complex competitive interaction among different MNO price strategies is often driving to fall in a prisoner's dilemma issue where competing MNOs are facing big challenges in defining the most appropriate and efficient pricing strategy. MNOs service prices can be randomized and thus no Nash equilibrium can be achieved (pure MNO strategies). On the other hand, each MNO can change its pricing strategy in a sequential game based on the best response of its competitor (mixed strategies). A Nash equilibrium (Yu & Kim, 2014) can be found by correlating both MNO best responses. The resolution of this linear generalized Nash equilibrium problem (LGNEP) helps to find the optimal wholesale price equilibrium and stabilize the oligopoly market by modeling and correlating the best response strategies of all competing players in their price competition game. The target is to define the Nash-equilibrium when no more improvement becomes possible from all competing MNOs (Phelps et al., 2013), (Stein & Sudermann-Merx, 2018), (Sun et al., 2018).

In Section 4.4.1, we defined an optimization algorithm as a planning tool for a single host MNO to optimize TCO for its coming V-MBH project. In reality, several MNOs are competing at the same time within the same oligopoly market to connect maximum traffic demand and win

biggest market share. All competing MNOs are always looking to minimize their expenditures and increase their revenues in order to maintain positive PPMs (Eq. (4.1)). Standard VBaaS proposed in Section 4.4.1 focuses in optimizing the TCO defined in Eq. (4.4) while the values of TSI wholesale prices  $P_w[y, t, i]$  are given (fixed) in Eq. (4.3). We optimize in Section 4.4.2 the ROI (Eq. (4.2)) as well by correlating the best pricing strategies for all competing MNOs and calculating the yearly pareto-Equilibrium prices for  $P_w[y, t, i]$ . These prices are then used to calculate the optimal ARPUs for each tenant and each TSI in Eq. (4.3) and used in Eq. (4.2) for the ROI calculation.

#### 4.4.2.2 Game definition

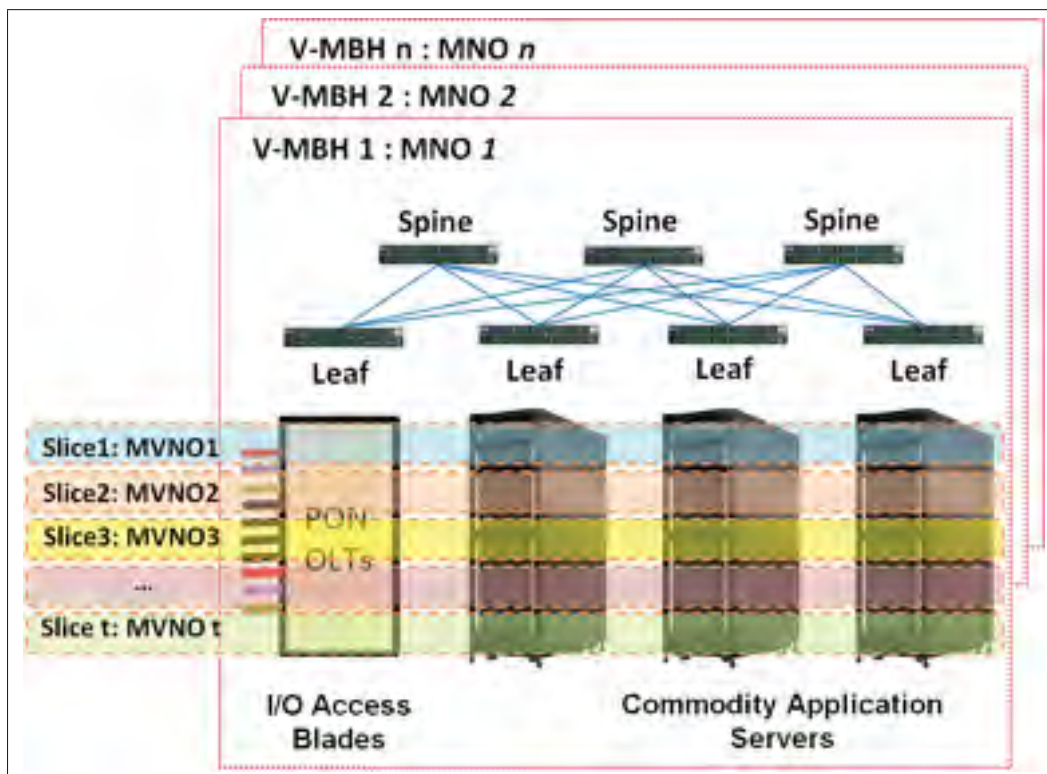

Figure 4.3 Slicing MNO V-MBH networks to MVNOs

Given the MBH network which is virtualized, sliced and is exploited by a set  $N$  of MNOs as shown in Fig. 4.3. We assume all MNOs have the same budget for CapEx and OpEx, using the same types of network equipment, and same network architecture. There is a set of MVNOs /

Tenants  $t \in T$  who are renting V-MBH slices (represented as TSIs  $i \in I$  in VBaaS model) at a wholesale price  $P_w[y, t, i]$  from a host MNO  $n \in N$  to connect a set of towers. Thus, each TSI  $i \in I$  rented by tenant  $t \in T$  may bring a certain revenue per each year. Each MNO  $n \in N$  has to choose a strategy to activate its hardware equipment in order to maximize its revenue according to Eq. (4.1), but taken into account the competition of other MNOs. So, a MNO may have to activate its equipment earlier (or later) than the optimal time in Eq. (4.1). The problem is to find the best schedule for all MNOs to activate their equipment and to meet Nash-equilibrium (if any MNO activates an equipment earlier or later of this time, some others will have to suffer). Indeed, if an MNO activates his network equipment sooner (e.g. in the first years of the project), higher traffic demand will be afforded, and more customers can be served earlier. However, his price will also be higher as a result of high CapEx investment and low revenue as seen in the TCO\_OPT problem. Such higher price may eventually result in customer lost in subsequent years. On the other hand, if the MNO delays the deployment of his network equipment to later years, he may offer a lower price but risks losing customers in the first years. The optimal time (activation year) is relying on the network capacity  $k_m[y, t, i]$  yearly dedicated by MNO  $n \in N$  to each of his tenants as well as the yearly revenue  $ARPU^{TSI}[y, t, i]$  generated by each TSI. Each competing player (host MNO  $n \in N$ ) sets his own quantity and pricing strategy in a non-cooperative transportation problem (NTP) (Stein et al., 2018) to plan his network deployment and increase his market share. In real world, network capacities may be planned but prices increase and decrease all the time. This makes the market instable without a pure Nash Equilibrium as highlighted by *Proposition 1* in (Yu et al, 2014).

#### 4.4.2.3 Mathematical model

We use of *Proposition 2* in (Yu & Kim, 2014) that limits the number of price changes within a certain period of time in order to push prices to merge into a Pareto-optimal equilibrium point. MNOs' best responses are driven by different service ARPUs for each tenant which is proportional to the wholesale prices as defined in Eq. (4.3). We define the optimal activation time for the V-MBH resources by calculating the equilibrium point  $(P_n^{eq}[y, t, i], \forall n \in N)$  for

a certain TSI  $i \in I$  offered by several competing MNOs  $n \in N$  to a tenant (customer)  $t \in T$ . We use the model defined by *Lemma 4* in (Yu & Kim, 2014) which is the outcome of the introduced two-stage Cournot and Bertrand competition model to study the price dynamics among several competing MNOs. We generalize in our work the definition of the normalized network capacities respectively calculated for MNOs  $m, n \in N$  in the Cournot stage (quantity competition) to consider the capacities  $k_m[y, t, i]$  and  $k_n[y, t, i]$  dedicated for the TSI  $i \in I$  offered to the tenant  $t \in T$  on yearly basis. Then the prices  $P_m^{eq}[y, t, i]$  and  $P_n^{eq}[y, t, i]$  are calculated in the Bertrand stage (price competition) for these given network capacities. The pareto-equilibrium prices are calculated in the model defined in Eq. (4.13). These prices are used to optimize ARPUs in Eq. (4.3) and ROI in Eq. (4.2).

$$(P_m^{eq}[y, t, i], P_n^{eq}[y, t, i]) = \left\{ \begin{array}{l} \left( \frac{1}{k_m[y, t, i] + 2}, \frac{k_m[y, t, i] + 1}{k_m[y, t, i] + 2} \right) \text{ if } k_m[y, t, i] < 2k_n[y, t, i] \\ \left( \frac{1}{k_m[y, t, i] + 2}, \frac{k_m[y, t, i] + 1}{k_m[y, t, i] + 2} \right) \text{ or} \\ \left( \frac{2k_n[y, t, i] + 1}{2(k_n[y, t, i] + 2)}, \frac{1}{2} \right) \text{ if } k_m[y, t, i] = 2k_n[y, t, i] \\ \left( \frac{2k_n[y, t, i] + 1}{2(k_n[y, t, i] + 2)}, \frac{1}{2} \right) \text{ if } k_m[y, t, i] > 2k_n[y, t, i] \end{array} \right. \quad (4.13)$$

#### 4.5 Validation and results

The TCO analysis is executed as part of the network planning phase to plan the resources distribution over the coming number of years (e.g. five years). Thus, no real-time solution of the problem is required and we can use mathematical solver to compute optimal solutions. In this paper, IBM ILOG CPLEX has been used as a solver for our VBaaS ILP problem on simulation

scenarios. The solver is running on a Windows 7 HP machine with i7-4790 CPU @ 3.6 GHz and 8 GB RAM specs.

Table 4.4 Input parameters.

V-MBH network element	Cost in USD
Project runtime	$Y = 5$
Number of competing host MNOs	$N = 3$
Leaf-to-spine ratio	$\alpha = 4$
Max. number of leaf switches	$l_{max} = 8$
Max. servers per leaf switch	$s_{max} = 8$
Max. compute instances per server	$v_{max} = 4$
Max. blades per compute instance	$b_{max} = 8$
Max. CPEs per access blade	$c_{max} = 32$
Number of TSIs per CPE	$i_{max} = 1..6$
CapEx Spine/Leaf Switches	$CX_{spine} = CX_{leaf} = 12000$
CapEx for <b>owned</b> commodity server	$CX_{srv}^{owned} = 15000$
CapEx for compute instances	$CX_{vm} + CX_{vlf} = 5000$
CapEx for I/O access blade	$CX_{bld} = 2000$
CapEx for PON port + Fiber connect.	$CX_{bld} = 10000$
CapEx for commodity CPE	$CX_{cpe} = 2000$
OpEx for spine / leaf switch	$OX_{spine} = OX_{leaf} = 6000$
OpEx for <b>owned</b> commodity server	$OX_{srv}^{owned} = 7500$
OpEx for <b>rented</b> commodity server	$OX_{srv}^{rented} = 3000$
OpEx for <b>owned</b> compute instances	$OX_{vm}^{owned} = 2500$
OpEx for <b>rented</b> compute instances	$OX_{vm}^{rented} = 2000$
OpEx for access blade	$OX_{bld} = 1000$
OpEx for PON port + Fiber connect.	$OX_{bld} = 5000$
OpEx for commodity CPE	$OX_{cpe} = 1000$
First time discount (only CapEx)	$\delta_{CX}[1] = 10 \text{ percent}$
Yearly bulk discount (CapEx and OpEx)	$\delta[y] = 2 \text{ percent}$
Yearly ARPU per TSI $i \in I$ (Random)	$ARPU = 2^{i-1} * 600$
Normalized network capacities	$k_m^{eq}[y, t, i] = k_n^{eq}[y, t, i] = 1$
Normalized Pareto-Equilibrium prices	$P_m^{eq}[y, t, i], P_n^{eq}[y, t, i] = (\frac{1}{3}, \frac{2}{3})$



#### 4.5.1 Use case definition

We use GPON-based V-MBH as defined in R-CORD project to validate the performance of our proposed VBaaS cost model detailed in Section 4.4.1. A GPON splitting ratio of 1:32 is applied which corresponds to the number of GPON ONTs (CPEs) per each OLT I/O access blade port ( $C_{max} = 32$ ). Input parameters are defined in Table 4.4. Cost of PON ports implicitly includes costs of fiber connectivities required to connect remote CPEs. Costs related to deploy fiber cable infrastructure are excluded from our models and are subject to separate TCO analysis project. We apply VBaaS to various scenarios of software based optical V-MBH networks (Table 4.1) and compare with traditional hardware based MBH (T-MBH) scenario. Cost values used in our study are based on published costs and industry-based estimates.

#### 4.5.2 T-MBH vs V-MBH

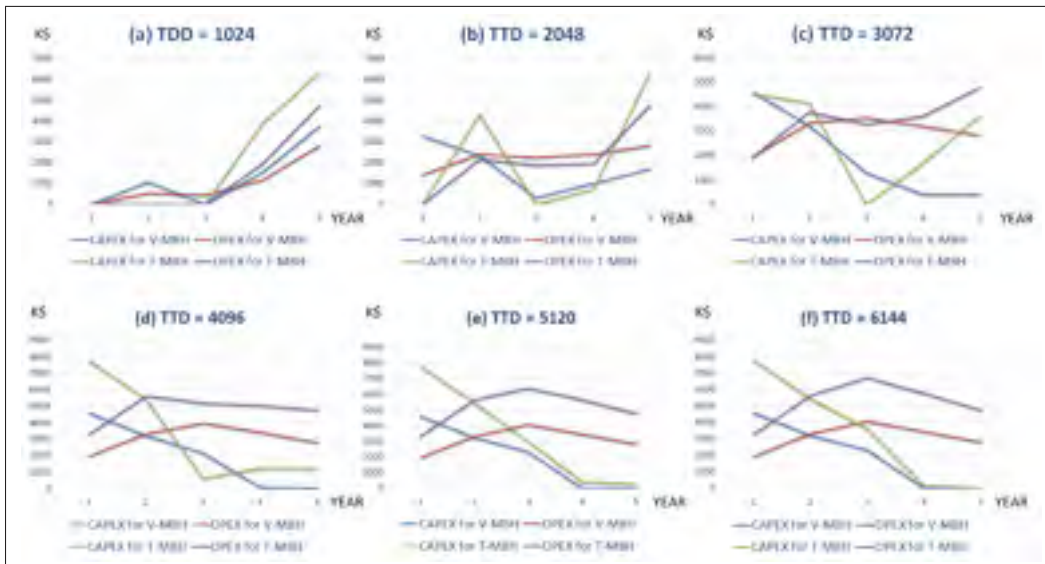

Figure 4.4 CapEx and OpEx yearly evolution for T-MBH vs V-MBH

We compare the yearly evolution of CapEx, OpEx, TCO and ROI for PON based T-MBH versus V-MBH. We compare as well the PPM for standard V-MBH scenario (where MNO owns his own infrastructure) versus the Renting servers and VNFaaS scenarios (MVNOs). Fig. 4.4 compares the yearly cost evolution for T-MBH versus V-MBH scenarios applied on



PON based CORD use-case. We vary the Total Traffic Demand (TTD) and track the variation of CapEx and OpEx on yearly basis. Results show the advantage of virtualizing MBH network since the very low traffic demand. For TTD = 1024, the planning and optimization algorithm delays deployment and activation of resources until the fourth year in order to optimize PPM. On the other hand, V-MBH deploys a first patch of resources on the second year and starts earlier satisfying TSI requests and generate revenues to MNO. Further expansions are required starting from the fourth year. CapEx and OpEx follow the same pace but V-MBH shows much lower costs than T-MBH. For TTD = 2048, a big T-MBH resource deployment and activation are scheduled on the second year with planned expansions starting in the fourth year while V-MBH project starts earlier with biggest investment in the first year and lower pace in coming years. The fifth year shows a huge CapEx and OpEx advantages for V-MBH versus T-MBH. For TTD = 3072, both T-MBH and V-MBH start deployment on the first year with almost same amount of investment but a big expansion is very soon required (starting from the fourth year) for T-MBH. No more expansion is required for V-MBH but a small investment is required to buy extra CPEs. Starting from TTD = 4096, both CapEx and OpEx for T-MBH and V-MBH start having almost same behaviour with a very big difference in cost values. Results confirm the big cost reduction for V-MBH compared to T-MBH in both CapEx and OpEx. For high traffic demand (TTD = 5120 and 6144), costs for V-MBH become almost stable since most of traffic demand is satisfied in the fourth year and no more resource activation is required. For T-MBH, CapEx and OpEx are slightly higher on the third year for TTD = 6144 compared with 5120 which shows that more CPEs are still being deployed to satisfy the extra traffic demand. All traffic demand is satisfied in the fifth year.

Fig. 4.5 compares the yearly evolution of invested costs (TCO) and generated revenues (ROI) for T-MBH versus V-MBH. The project become profitable when ROI curve exceeds TCO curve. For TTD = 1024, T-MBH starts generating revenue in the fourth year but with very low values compared with invested TCO. So, the project is not yet making any profit margins with this low traffic demand. On the other hand, V-MBH generates small revenues with same traffic demand starting from the second year with much lower invested TCO than T-MBH.

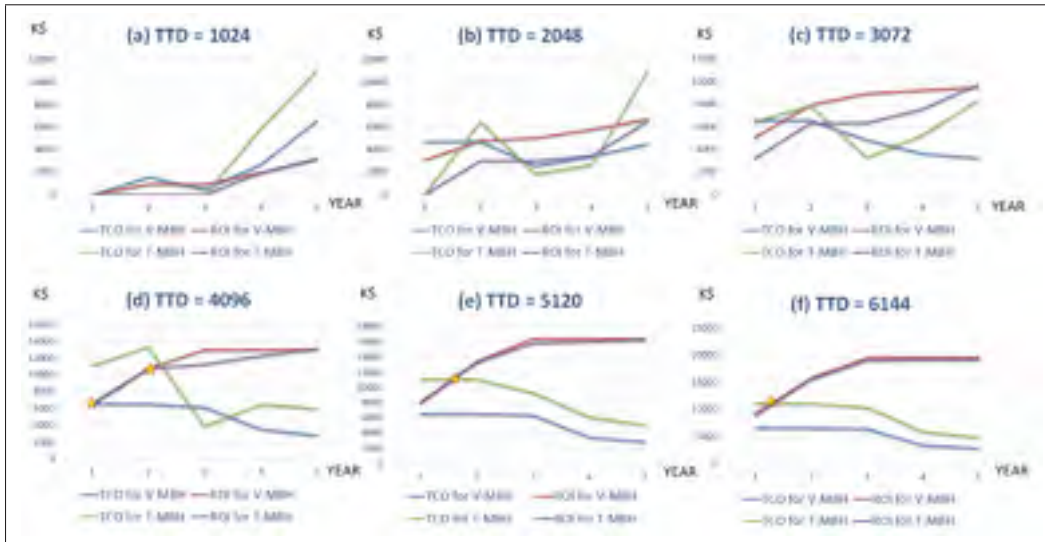

Figure 4.5 TCO and ROI yearly evolution for T-MBH vs V-MBH

Nevertheless, TCO remains much higher than ROI till the fifth year and the project is thus not yet profitable. For  $TTD = 2048$ , revenue generation starts earlier than previous case but ROI is still low compared with invested TCO for both T-MBH and V-MBH. While T-MBH project is not yet profitable, the project starts generating small profit margin since the second year using V-MBH. This result already shows the advantage of choosing a virtualized approach to build future MBH network that generates revenue sooner than traditional networks. However, T-MBH starts also being profitable at slow pace when traffic demand increases. For  $TTD = 3072$ , ROI curve exceeds TCO one for T-MBH around the third year. V-MBH ROI keeps increasing in a fast pace while TCO continue to drop. Most of investment costs are spent in the first two years of the project. Only costs related to procure extra CPEs and to operate the network remain inevitable. Starting from  $TTD = 4096$ , V-MBH network is generating more revenue than costs since the first year. The gap between ROI and TCO keep increasing with high traffic demand until reaching the maximum revenue generation possible. ROI becomes constant starting from the third year while TCO continue to drop slowly. For very high traffic demand ( $TTD = 5120$  and  $6144$ ), most of traffic requests are satisfied and both T-MBH and V-MBH are generating their maximum revenues. ROI curves start to merge for both scenarios and becomes constant in the third year. MNO is generating his maximum revenue for both MBH

projects but his TCO remains higher for T-MBH compared with V-MBH. This concludes again the advantage of virtualization in reducing costs for MBH projects.

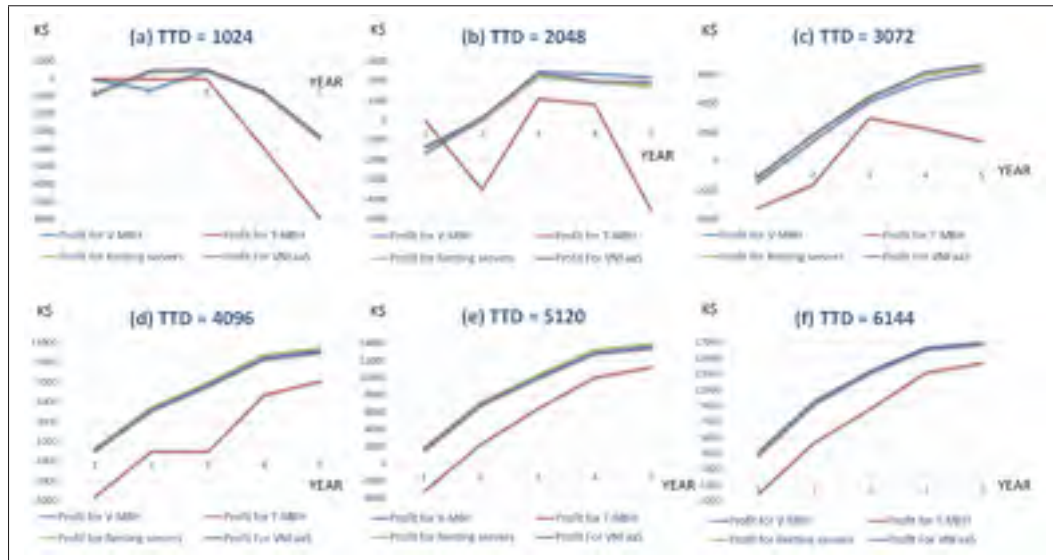

Figure 4.6 PPM yearly evolution for T-MBH vs V-MBH, Renting servers and VNFaaS scenarios

Fig. 4.6 summarizes the yearly evolution of PPM for T-MBH versus V-MBH (with the different scenarios summarized in Table 4.1). Results show that for very low traffic demand (TDD = 1024), both T-MBH and V-MBH profit margins are negative. Thus the project is not yet profitable. Although V-MBH presents a positive PPM for the second and third year, the increasing TCO in the fourth year without enough revenue generation is driving to a negative profit for coming years. Furthermore, results show that renting VMs (VNFaaS) and/or servers offers a slight advantage in the second and third year compared with the standard V-MBH scenario where MNO deploys his own network. For TTD = 2048, software-based MBH scenarios offer a clear advantage over T-MBH. The project starts to be profitable in the second year while T-MBH is still presenting negative PPM. Deploying its own network resources presents a slight advantage to MNO compared with the scenario where renting VMs and/or servers from a third-part provider. At TTD = 3072, T-MBH starts to have a positive PPM on the third year while software networks are generating a positive profit before the second year. Results also show that VNFaaS (and renting servers) offers a higher PPM compared to the standard V-MBH sce-

nario. For high traffic demand (starting from TTD = 4096), PPM graphs of software-based scenarios (standard V-MBH, VNFaaS and renting servers) start merging with a much higher values compared to T-MBH. For TTD = 6144, the three curves of previous software-based scenarios are merging showing that - for very high traffic demand - it does not matter anymore if the MNO buys/deploys or rents his VMs and/or servers. In fact, most of TCO is consumed on the access components such CPEs, access blades and not on the computing side of the network.

### 4.5.3 Pareto-equilibrium price

We consider the Canadian market as an example with three (3) major competing MNOs (Bell, Rogers and Telus). We use the MNO Pricing Game (MPG) defined in Section 4.4.2 to calculate the Equilibrium prices. We consider the case where all MNOs are sharing the yearly traffic demand in an equitable way with no monopolism. Thus, we assume the simplest case where the normalized network capacities for all competing MNOs are equal to 1, meaning that,  $k_n[y, t, i] = 1, \forall n \in N, y \in Y, t \in T$  and  $i \in I$ . We use the first case (i.e.  $k_m[y, t, i] < 2 k_n[y, t, i]$ ) in the Equilibrium model defined by Eq. (4.13) to calculate the pareto-equilibrium prices for MNO 2 and 3 based on the randomized prices of MNO 1. The normalized pareto-equilibrium prices are calculated as follows ( $P_m^{eq}[y, t, i], P_n^{eq}[y, t, i] = (1/3, 2/3)$ ). Thus, knowing the wholesale pricing strategy of MNO 1, his competitor MNO 2 will define his best strategy by leasing his TSIs with higher price and enhance his revenues in a pareto-equilibrium market situation. Same, MNO 3 will define his prices based on the calculated prices of MNO 2. We exclude the case where all MNOs define their pricing strategies at exactly the same time with no knowledge about competitors behavior.

Fig. 4.7 presents the yearly evolution for V-MBH Project Profit Margin (PPM) for Randomized pricing (MNO 1) versus Pareto-Equilibrium pricing (MNO 2 and 3). Results show the big advantage of using the Pareto-Equilibrium pricing strategy to define MNO service prices and enhances the profitability of V-MBH for all traffic demand volumes. For instance, V-MBH is not profitable for very low traffic demand (TTD =1024) when using randomized pricing strategy (MNO 1) while it becomes profitable with Pareto-Equilibrium pricing strategy (MNO

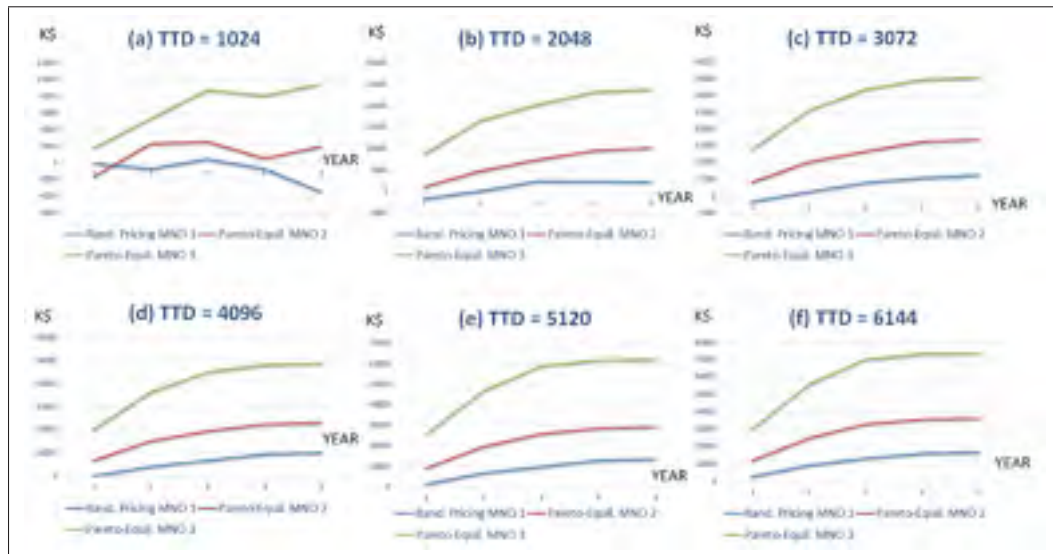

Figure 4.7 PPM yearly evolution for V-MBH using Randomized pricing versus Equilibrium pricing

2 and 3). Furthermore, MNO 3 generate more profit than MNO 2 concluding that the MNO making later decision based on previous ones will have more chances for higher profit margins. We conclude also that the profitability of V-MBH project increases with high traffic demand.

Fig. 4.8 summarizes and validates previous conclusions for the Total PPM for the entire project runtime ( $Y$ ). Unlike the evolution of PPM on yearly basis discussed in Fig. 4.7, results in this paragraph focus on the final PPM of the whole project without considering detailed yearly behavior. At the end of the project lifetime, the project is either profitable enough or not. The outcome of this result helps the MNO decide which strategy to use for building his future MBH network. Thus, he may decide to build his own infrastructure as a host MNO (e.g. T-MBH or standard V-MBH) or to go for renting resources (servers, VNFaaS) as an MVNO. he can also decide on which pricing strategy to adopt based on his competition best strategy. By comparing the Total PPM for all previously discussed scenarios, Fig. 4.8 shows that for  $TTD = 1024$ , only V-MBH with Pareto-Equilibrium pricing is profitable while all remaining PPMs are negative. For  $TTD = 2048$ , only T-MBH is still not profitable. Starting from  $TTD = 3072$ , all project scenarios become profitable with a very big advantage to V-MBH with Pareto-Equilibrium pricing.

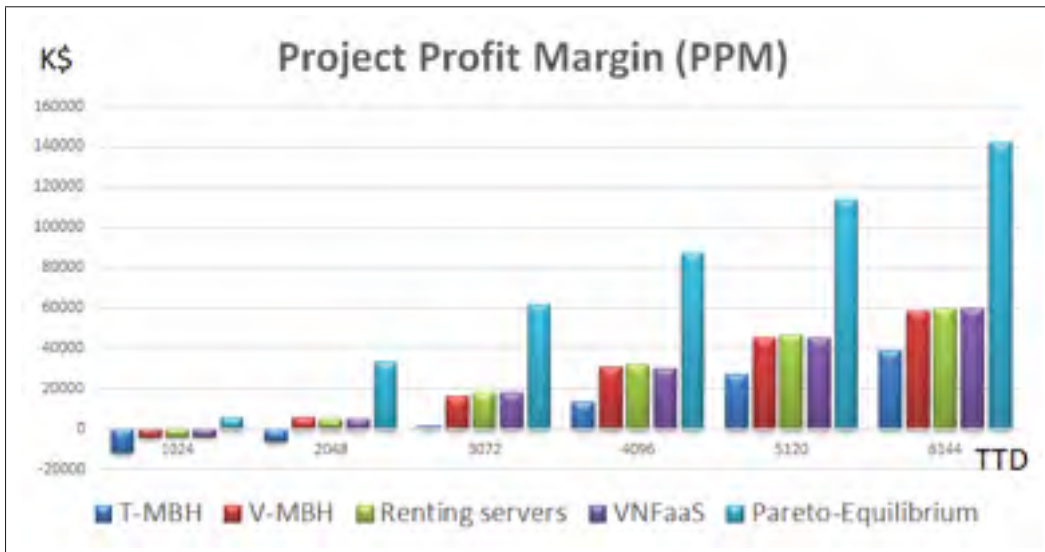

Figure 4.8 Total PPM for T-MBH vs V-MBH using Randomized pricing and Equilibrium pricing

#### 4.6 Conclusion

Future 5G multi-tenant Mobile BackHaul networks (MBH) are facing a continuous increase in traffic demand, particularly with coming greedy applications like IoT, smart cities and connected cars. Building and operating such networks require huge investments while generated revenues remain flat. Thus, a combination of efficient choice of technology, optimized resource planning and smart service pricing strategy is urging to guaranty the MBH network profitability and enhance the Project Profit Margins (PPM). In this paper, we proposed an optimization model to optimize the network PPM for a typical SDN- and NFV-based Virtualized MBH (V-MBH) use-case (called CORD project) while considering the yearly consumed Total Cost of Ownership (TCO) and generated Return-on-investment (ROI). Simulation results provide useful understanding on various factors affecting the MBH network profitability. We applied the model on various scenarios where the Mobile Network Operator (MNO) may deploy its own network or rent computing resources such as servers and/or VMs. Then, we used game theory to find the Pareto-Equilibrium pricing strategy that optimizes the MNO's TCO planning based on competition strategies. Techno-economic analysis show the ability of recent SDN and NFV technologies such as centralized cloud computing to reduce deployment costs (CapEx) and op-



eration costs (OpEx). Furthermore, network slicing and multi-tenancy business models help to enhance network resources sharing and generate more revenues for MNOs. We conclude that the combination of deploying an MBH with software-based virtualized resources and using game theory to define the best pricing strategy significantly enhance the MNO generated revenues and increase the project profitability.

In the future, we will study the game theoretic problem of pricing for application providers that use MVNO networks.

#### **4.7 Acknowledgement**

The authors thank NSERC and Ciena for funding the project CRDPJ 461084. This research also receives support from the Canada Research Chair, Tier 1, hold by Mohamed Cheriet. The view expressed in this article are those of the authors and do not reflect the official policy of Ciena.





## CONCLUSION AND RECOMMENDATIONS

### 5.1 General conclusion

5G technology is bringing several new challenges that are driving big network transformation and infrastructure modernization. The expected explosion in bandwidth requirements and number of connected devices, specially with coming greedy applications like IoT, smart cities and connected cars, is leading to tremendous expansions and new deployments. In particular, future 5G multi-tenant Mobile BackHaul networks (MBH) are facing an ever-increasing traffic demand to connect the millions of mobile towers to the core network. Building and operating such networks require huge budgets that may not be following the slow pace of generated revenues. A combination of efficient choice of reliable and cost-effective technology, optimized resource planning and smart service pricing strategy is required to enhance the MBH network scalability and maintain positive Project Profit Margins (PPM).

In this work, we reviewed the various empirical challenges faced by most of service providers in their network transformation process and we defined a detailed migration plan towards a flexible, reliable and cost-effective End-to-End Integrated Optical-Packet Network (E2IOPN). The E2IOPN is integrating GPON technology in the access and last-mile layer of the network to offer high bandwidth per user at low costs and reduced energy consumption. MPLS-TP replaces legacy transport technologies in the access and metro backhaul networks. Most of layer 3 traffic needs to be offloaded from expensive IP/MPLS routers in the core and metro aggregation layers to much lower cost OTN switches. High capacity DWDM transport network with gridless channels and flexible CDC ROADMs enhance the availability and scalability of the core network at very low cost per bit. We discussed also the benefits of recent SDN and NFV concepts in the transformation of the access, metro and core transport networks towards the E2IOPN.

We presented also an algorithm based on a stochastic geometry model (called Voronoi Tessellation) to more precisely define the 5G backhauling zones and estimate the required traffic demand. We first proposed a new pay-as-you-grow concepts called BackHauling-as-a-Service (BHaaS) to improve the performance and accuracy of network planning and TCO analysis for future 5G MBH networks. The proposed cost model optimize the distribution of CapEx and OpEx of Traditional MBH (T-MBH) over the project years based on total traffic demand, the yearly consumed Total Cost of Owneship (TCO) and generated Return-on-investement (ROI). We further enhanced the performance of BHaaS in a more service-aware model called Traffic-Profile-as-a-Service (TPaaS) by considering also the various prices of different offered traffic profiles. In a next step, we extended our work to address SDN- and NFV-based Virtualized MBH (V-MBH) networks. Unlike the T-MBH which is based on purpose-built hardware devices only, the software based V-MBH is using the recent network virtualization and multi-tenancy concepts to maximize resource sharing among various tenants. We proposed an optimization cost model called Virtual Backhaul as a Service (VBaaS) to optimize the network PPM for a typical V-MBH use-case in the industry called CORD project. We applied the cost models on various scenarios where the Mobile Network Operator (MNO) may build its own infrastructure or rent computing resources such as servers and/or Virtual Machines. Simulation results offer useful information on the different factors that affect the MBH network scalability and profitability. Finally, we used game theory to find the pareto-equilibrium pricing strategy based on competition strategies for MNOs leasing part of their resources (network slicing concept) to various Mobile Virtual Network Operators (MVNO). We compare the impact of using the calculated pareto-equilibrium prices against randomized pricing strategy on the overall network PPM.

## **5.2 Major contributions**

The highlight of the major contributions of this thesis are:

1. **End-to-End Integrated Optical Packet Network (E2IOPN):** A comprehensive as-built high-level design (HLD) as implemented by *SP* including practical integration (handshake) and inter-operability solutions between the various E2IOPN layers.
2. **Empirical analysis:** An empirical analysis of various challenges and issues faced by real service providers (SP) and mobile network operators (MNO) to migrate their brown-field legacy transport networks into more advanced E2IOPN.
3. **ONT remote activation algorithm:** We proposed an algorithm for automated remote activation of GPON ONTs (Optical Network Termination) .
4. **Throughput driven Real-Time Traffic Engineering (TRT-TE):** An SDN/NFV based longer-term strategy, and a Throughput driven Real-Time Traffic Engineering (TRT-TE) architecture as a novel centralized control plane to efficiently carry out real-time Traffic Engineering and minimize TCO for E2IOPN.
5. **CapEx and OpEx cost modeling:** A comprehensive CapEx and OpEx calculation model for optical MBH networks. A cost comparative study is proposed.
6. **BackHauling-as-a-Service (BHaaS):** A novel TCO analysis BackHauling-as-a-Service (BHaaS) method based on "You-pay-only-for-what-you-use" to optimize yearly planned installation and activation of resources based on estimated traffic demands and generated revenues.
7. **Traffic-Profile-as-a-Service (TPaaS):** An advanced Traffic-Profile-as-a-Service (TPaaS) method that further improves the BHaaS model by considering the various costs of different traffic profiles.
8. **Backhauling zones algorithm:** A novel algorithm based on Voronoi Tessellation stochastic geometry to more precisely define the backhauling zones within a geographical area and optimize their estimated traffic demands.

9. **TCO models for Virtualized MBH (V-MBH):** We propose a detailed costs formulation for SDN/NFV based 5G multi-tenant Virtualized MBH (V-MBH) by considering the software components.
10. **Virtual-Backhaul-as-a-Service (VBaaS):** We introduce a novel pay-as-you-grow and service-aware optimization model called *Virtual-Backhaul-as-a-Service (VBaaS)* as a planning tool to plan yearly activation of required Tenant Service Instances (TSIs) and execution of VNFs while optimizing the PPM (TCO versus ROI) for future V-MBH projects.
11. **MNO Pricing Game (MPG):** We model the interaction between resource activation and price strategies of multiple competing MNOs by Bertrand price competition game, and then we calculate the optimal Pareto-Equilibrium prices for TSIs to further optimize the PPM and to define to which extent MNO shall invest to improve its offered SLAs.

### 5.3 Discussion and future work

Techno-economic analysis show the efficiency of proposed BHaaS, TPaaS and VBaaS methods compared with traditional TCO models in optimizing and calculating the entire TCO. The proposed cost models drive MNOs to quickly start generating positive PPM while satisfying the required traffic demands. Simulation results show the advantage of emerging SDN and NFV technologies such as network virtualization and centralized cloud computing to reduce CapEx and OpEx. Moreover, recent network slicing and multi-tenancy business models help to maximize the resource sharing of the MNO networks and generate higher ROI. We conclude that the combination of deploying a backhauling network with software-based virtualized resources and using game theory to define the best pricing strategy significantly enhance the generated revenues and increase the profitability of the MNO project. Service providers and network operators will be able to sustain to new market changes and maintain good profit margins. This

is crucial for the evolution of all transport networks regarding the advent of new 5G and cloud computing applications.

On the other hand, it is worth noting that the proposed TCO models are rather appropriate for business model based on the "You-pay-only-for-what-you-use" approach. These models may have some shortcomings for traditional service providers that may lose potential customers due to postponing the deployment and activation of network resources, and thus, delaying satisfied traffic demand. Customers with urgent demand may, for instance, go for different service provider that initially invest huge budgets to immediately afford required traffic demand. In this case, this later service provider may gain new customers. This issue will be addressed in our future work by an efficient demand prediction which takes into account market behaviors. We intent also to design a heuristic algorithm to reduce the relatively high calculation time that increases with the given Total Traffic Demand (TTD).

#### **5.4 Articles in peer-reviewed journals and conferences**

1. N. Haddaji, K. Nguyen and M. Cheriet, "Transformative Design Model towards an End-to-end Integrated-Optical-Packet-Network in Metro and Core Networks", IEEE Communications Society, Networks 2016 Conference, September 2016.
2. N. Haddaji, K. Nguyen and M. Cheriet, "Towards End-to-End Integrated Optical Packet Network: Empirical Analysis," Elsevier, Optical Switching and Networking, June 2017.  
DOI: 10.1016/j.osn.2017.06.003.
3. N. Haddaji, A. Bayati, K. Nguyen, and M. Cheriet, "Backhauling-as-a-Service (BHaaS) for 5G Optical Sliced Networks: An Optimized TCO Approach", IEEE OSA, Journal of Lightwave Technology, July 2018.  
DOI: 10.1109/JLT.2018.2855148

4. N. Haddaji, K. Nguyen and M. Cheriet, "TCO Planning Game for 5G Multi-Tenant Virtualized Mobile BackHaul (V-MBH) Network", submitted to IEEE OSA, Journal of Light-wave Technology, January 2019.
5. N. Haddaji, K. Nguyen and M. Cheriet, "Optimizing Profit Margins for 5G Multi-Tenant Virtualized Mobile BackHaul (V-MBH) Network", submitted to 15th International Wireless Communications & Mobile Computing Conference, June 2019.

## BIBLIOGRAPHY

- A. Agata and Y. Horiuchi, "PON network designing algorithm for suboptimal deployment of optical fiber cables," 2009 Asia Communications and Photonics conference and Exhibition (ACP), Shanghai, 2009, pp. 1-6.
- A. Bayati, V. Asghari, K. Nguyen and M. Cheriet, "Gaussian Process Regression Based Traffic Modeling and Prediction in High-Speed Networks," 2016 IEEE Global Communications Conference (GLOBECOM), Washington, DC, 2016, pp. 1-7.
- A. Castro et al., "Experimental Assessment of Bulk Path Restoration in Multilayer Networks Using PCE-based Global Concurrent Optimization," in *Journal of Lightwave Technology*, vol. 32, no. 1, pp. 81-90, Jan.1, 2014.
- A. D. La Oliva et al., "Xhaul: toward an integrated fronthaul/backhaul architecture in 5G networks," in *IEEE Wireless Communications*, vol. 22, no. 5, pp. 32-40, October 2015.
- A. E. Baert and D. Seme, "Voronoi mobile cellular networks: topological properties," *Third International Symposium on Parallel and Distributed Computing/Third International Workshop on Algorithms, Models and Tools for Parallel Computing on Heterogeneous Networks*, 2004, pp. 29-35.
- A. Ehrhardt, L. Schuerer, F. Escher, B. Nagel and H. M. Foisel, "ONT reflection for additional maintenance by OTDR-measurements in FTTH networks," 2013 Optical Fiber Communication Conference and Exposition and the National Fiber Optic Engineers Conference (OFC/NFOEC), Anaheim, CA, 2013, pp. 1-3.
- A. G. Malis, "MPLS-TP: Where are we?," OFC/NFOEC, Los Angeles, CA, 2012, pp. 1-3.
- A. Giorgetti, F. Paolucci, F. Cugini, and P. Castoldi, "Proactive Hierarchical PCE based on BGP-LS for Elastic Optical Networks," in *Optical Fiber Communication Conference, OSA Technical Digest (online) (Optical Society of America, 2015)*, paper Th1A.3.
- A. Golnari, M. Shabany, A. Nezamalhosseini and G. Gulak, "Design and Implementation of Time and Frequency Synchronization in LTE," in *IEEE Transactions on Very Large-Scale Integration (VLSI) Systems*, vol. 23, no. 12, pp. 2970-2982, Dec. 2015.
- A. Gumaste and S. Akhtar, "Evolution of packet-optical integration in backbone and metropolitan high-speed networks: a standards perspective," in *IEEE Communications Magazine*, vol. 51, no. 11, pp. 105-111, November 2013.
- A. Gupta and R. K. Jha, "A Survey of 5G Network: Architecture and Emerging Technologies," in *IEEE Access*, vol. 3, no. , pp. 1206-1232, 2015.

- A. Jarray, B. Jaumard and A. C. Houle, "Reducing the CapEx and OpEx Costs of Optical Backbone Networks," 2010 IEEE International Conference on Communications, 2010, pp. 1-5.
- A. K. Agarwal and L. D. Hutcheson, "Performance and reliability of optical fiber connectors in the outside plant environment," in IEEE Transactions on Components, Packaging, and Manufacturing Technology: Part B, vol. 18, no. 2, pp. 221-226, May 1995.
- A. Khan, W. Kellerer, K. Kozu and M. Yabusaki, "Network sharing in the next mobile network: TCO reduction, management flexibility, and operational independence," in IEEE Communications Magazine, vol. 49, no. 10, pp. 134-142, Oct. 2011.
- A. Ledjjar, E. Sampin, C. Talhi and M. Cheriet, "Network Function Virtualization as a Service for multi-tenant software defined networks," 2017 Fourth International Conference on Software Defined Systems (SDS), 2017, pp. 168-173.
- A. Mathew, T. Das, P. Gokhale and A. Gumaste, "Multi-layer high-speed network design in mobile backhaul using robust optimization," in IEEE/OSA Journal of Optical Communications and Networking, vol. 7, no. 4, pp. 352-367, April 2015.
- A. Mukhopadhyay and G. Das, A Ring-Based Wireless Optical Network to Reduce the Handover Latency. JOURNAL OF LIGHTWAVE TECHNOLOGY, VOL. 33, NO. 17, SEPTEMBER 1, 2015.
- A. Nag, M. Furdek, P. Monti, L. Wosinska, and M. Ruffini, Exploiting Dual Homing in Access Networks to Improve Resiliency in Core Networks. J. OPT. COMMUN. NETW./VOL. 8, NO. 11/NOVEMBER 2016.
- A. Ouali and K. F. Poon, "Optimal design of GPON/FTTH networks using mixed integer linear programming," 2011 16th European Conference on Networks and Optical Communications, Newcastle-Upon-Tyne, 2011, pp. 137-140.
- A. Ouali, K. F. Poon, B. S. Lee and K. A. Romaihi, "Towards achieving practical GPON FTTH designs," 2015 IEEE 20th International Workshop on Computer Aided Modelling and Design of Communication Links and Networks (CAMAD), Guildford, 2015, pp. 108-113.
- A. S. Thyagaturu, A. Mercian, M. P. McGarry, M. Reisslein and W. Kellerer, "Software Defined Optical Networks (SDONs): A Comprehensive Survey," in IEEE Communications Surveys and Tutorials, vol. 18, no. 4, pp. 2738-2786, Fourth quarter 2016.
- A. Vallat and D. Schneuwly, "Clock Synchronization in Telecommunications via PTP (IEEE 1588)," 2007 IEEE International Frequency Control Symposium Joint with the 21st European Frequency and Time Forum, Geneva, 2007, pp. 334-341.
- B. A. G. Hillen, I. Passchier, E. F. Matthijssen, F. T. H. den Hartog and F. Selgert, "Remote management of mobile devices with broadband forum's TR-069," Networks 2008 - The 13th



- International Telecommunications Network Strategy and Planning Symposium, Budapest, 2008, pp. 1-7.
- B. Kim, W. Lee and J. Han, "Outside plant architecture of fiber-based access network," Digest of the 9th International Conference on Optical Internet (COIN 2010), Jeju, 2010, pp. 1-3.
- Beller, Dieter, and Rolf Sperber. "MPLS-TP-The New Technology for Packet Transport Networks." DFN-Forum Kommunikationstechnologien. Vol. 149. 2009.
- Bogineni, Kalyani, et al. "LTE part II: Radio access." IEEE Communications Magazine 47.4 (2009): 40-42.
- C. Addeo, G. Cazzaniga, R. Crescentini and F. Valente, "On QoS mechanism profiling in MPLS-TP transport networks," in Bell Labs Technical Journal, vol. 14, no. 4, pp. 227-241, Winter 2010.
- C. Bouras, P. Ntarzanos and A. Papazois, "Cost Modeling for SDN/NFV Based Mobile 5G Networks", 8th International Congress on Ultra Modern Telecommunications and Control Systems and Workshops (ICUMT), 2016.
- C. Cao, Y. Zhang, J. Zhang, X. Cheng and W. Gu, "Packet-Level Optimization for Transmission Performance Improvement of Internet-Bound Traffic in a MPLS-TP Network," in IEEE/OSA Journal of Optical Communications and Networking, vol. 2, no. 11, pp. 991-999, November 2010.
- C. Cao, Y. Zhang, J. Zhang, X. Cheng and W. Gu, "Packet-Level Optimization for Transmission Performance Improvement of Internet-Bound Traffic in a MPLS-TP Network," in IEEE/OSA Journal of Optical Communications and Networking, vol. 2, no. 11, pp. 991-999, November 2010.
- C. E. Tsirakis, P. Matzoros and G. Agapiou, "State-of-the-art on Virtualization and SDN for efficient resource allocation on Multi-tenant 5G networks", 21st International Conference on Circuits, Systems, Communications and Computers, July 2017.
- C. Kachris and I. Tomkos, "A Survey on Optical Interconnects for Data Centers," in IEEE Communications Surveys and Tutorials, vol. 14, no. 4, pp. 1021-1036, Fourth Quarter 2012.
- C. S. Ranaweera, P. P. Iannone, K. N. Oikonomou, K. C. Reichmann, and R. K. Sinha, Design of Cost-Optimal Passive Optical Networks for Small Cell Backhaul Using Installed Fibers. J. OPT. COMMUN. NETW./VOL. 5, NO. 10/OCTOBER 2013.
- C. Zhang et al., "Field trial of bandwidth on demand services based on hierarchical control over multi-domain OTN networks," in IEEE/OSA Journal of Optical Communications and Networking, vol. 7, no. 11, pp. 1057-1063, November 1 2015.

- C. Zukowski, D. B. Payne and M. Ruffini, "Modelling accurate planning of PON networks to reduce initial investment in rural areas," 2014 International Conference on Optical Network Design and Modeling, Stockholm, 2014, pp. 138-143.
- Chun, K. G., Kwon, Y., Kim, H., and Song, J. (2014). Architecture of an Enhanced Packet-Optical Transport System. *International Journal of Multimedia and Ubiquitous Engineering*, 9(4), 63-72.
- Cyan, Inc, Redefining Packet-Optical Transport Accelerating Network Transformation with Multi-layer SDN and 100GbE. WHITE PAPER, 2014.
- D. Astely, E. Dahlman, A. Furuskär, Y. Jading, M. Lindström and S. Parkvall, "LTE: the evolution of mobile broadband," in *IEEE Communications Magazine*, vol. 47, no. 4, pp. 44-51, April 2009.
- D. C. Mur, P. Flegkas, D. Syrivelis, Q. Wei and J. Gutiérrez, "5G-XHaul: Enabling Scalable Virtualization for Future 5G Transport Networks," 2016 15th International Conference on Ubiquitous Computing and Communications and 2016 International Symposium on Cyberspace and Security (IUCC-CSS), 2016, pp. 173-180.
- D. Ford, R. Quintal and A. McCuthy, "A new approach to outside plant planning of the fiber feeder network in Bell Canada's Metropolitan core areas," *Proceedings. The X International Symposium on Subscriber Loops and Services*, 1993, pp. 71-77.
- D. U. Kim, Y. C. Ryoo, B. Kim and J. Lee, "OAM and protection mechanisms for MPLS-TP packet transport networks," 2014 12th International Conference on Optical Internet 2014 (COIN), Jeju, 2014, pp. 1-4.
- F. Baccelli and A. Giovanidis, "A Stochastic Geometry Framework for Analyzing Pairwise-Cooperative Cellular Networks," in *IEEE Transactions on Wireless Communications*, vol. 14, no. 2, pp. 794-808, Feb. 2015.
- F. Effenberger et al., "An introduction to PON technologies [Topics in Optical Communications]," in *IEEE Communications Magazine*, vol. 45, no. 3, pp. S17-S25, March 2007.
- F. Huang, X. Yi, H. Zhang and P. Gong, "Key requirements of packet transport network based on MPLS-TP," 2009 Asia Communications and Photonics conference and Exhibition (ACP), Shanghai, 2009, pp. 1-7.
- F. Rambach et al., "A multilayer cost model for metro/core networks," in *IEEE/OSA Journal of Optical Communications and Networking*, vol. 5, no. 3, pp. 210-225, March 1 2013.
- F. Sun, F. Hou, H. Zhou, B. Liu, J. Chen, and L. Gui, "Equilibriums in the Mobile-Virtual-Network-Operator-Oriented Data Offloading", *IEEE TRANSACTIONS ON VEHICULAR TECHNOLOGY*, VOL. 67, NO. 2, FEBRUARY 2018.

- F. Zhu, Z. Chang, L. Wang and G. Fang, "100G OTN technology and deployment for carrier networks," OFC/NFOEC, Los Angeles, CA, 2012, pp. 1-3.
- G. N. Liu, "Transport-SDN: Enabling next-generation transport networks," 2014 OptoElectronics and Communication Conference and Australian Conference on Optical Fibre Technology, Melbourne, VIC, 2014, pp. 21-22.
- H. Chen et al., "Cost-minimized design for TWDM-PON based 5G mobile backhaul networks," in IEEE/OSA Journal of Optical Communications and Networking, vol. 8, no. 11, pp. B1-B11, Nov. 2016.
- H. Lee, K. k. Lee, S. Na and Y. Lee, "Challenges in the design and deployment for packet optical converged core network," 2014 16th International Telecommunications Network Strategy and Planning Symposium (Networks), Funchal, 2014, pp. 1-4.
- H. Rachidi and A. Karmouch, "A framework for self-configuring devices using TR-069," 2011 International Conference on Multimedia Computing and Systems, Ouarzazate, 2011, pp. 1-6.
- H. Schmuck, M. Straub, R. Bonk, J. Hehmann and T. Pfeiffer, "Embedded OTDR measurement range extension for future metro-access networks employing in-line SOAs," 2014 The European Conference on Optical Communication (ECOC), Cannes, 2014, pp. 1-3.
- Huang, F., Yi, X., Zhang, H., and Gong, P. (2008, November). Packet transport network in metro. In Asia Pacific Optical Communications (pp. 71371E-71371E). International Society for Optics and Photonics.
- <http://opencord.org/>, 2016.
- J. Costa-Requena, J. L. Santos and V. F. Guasch, "Mobile backhaul transport streamlined through SDN," 2015 17th International Conference on Transparent Optical Networks (ICTON), Budapest, 2015, pp. 1-4.
- J. Jasperneite, K. Shehab and K. Weber, "Enhancements to the time synchronization standard IEEE-1588 for a system of cascaded bridges," IEEE International Workshop on Factory Communication Systems, 2004. Proceedings., 2004, pp. 239-244.
- J. Kaippallimalil and H. A. Chan, "Network virtualization and direct Ethernet transport for packet data network connections in 5G wireless," 2014 IEEE Global Communications Conference, 2014, pp. 1836-1841.

- J. Maes, M. Guenach, K. Hooghe and M. Timmers, "Pushing the limits of copper: Paving the road to FTTH," 2012 IEEE International Conference on Communications (ICC), Ottawa, ON, 2012, pp. 3149-3153.
- J. N. Wu, C. C. Chan, P. Y. Chen and C. L. Chu, "Design and Implementation of an Auto-Configuration and Cooperation Generation of Web Service User Interface Based on TR-069 Protocol," 2012 9th International Conference on Ubiquitous Intelligence and Computing and 9th International Conference on Autonomic and Trusted Computing, Fukuoka, 2012, pp. 816-821.
- J. S. Choi, "Design and Implementation of a Stateful PCE-Based Unified Control and Management Framework for Carrier-Grade MPLS-TP Networks," in *Journal of Lightwave Technology*, vol. 34, no. 3, pp. 836-844, Feb.1, 1 2016.
- J. Santos, J. Pedro, P. Monteiro and J. Pires, "Optimized Routing and Buffer Design for Optical Transport Networks Based on Virtual Concatenation," in *IEEE/OSA Journal of Optical Communications and Networking*, vol. 3, no. 9, pp. 725-738, September 2011.
- J. Sommer et al., "Ethernet – A Survey on its Fields of Application," in *IEEE Communications Surveys and Tutorials*, vol. 12, no. 2, pp. 263-284, Second Quarter 2010.
- J. Verschoore De La Houssaye, M. Angel Alvarez Bernardo, Integrated QoS Management. NGMN Alliance, 2012.
- J. Wu, M. Savoie, S. Campbell and H. Zhang, "Service-Oriented Management Architecture of Optical Virtual Private Networks," 2007 IEEE Globecom Workshops, Washington, DC, 2007, pp. 1-3.
- J. Y. Sung, C. W. Chow, C. H. Yeh, Y. Liu and G. K. Chang, "Cost-Effective Mobile Backhaul Network Using Existing ODN of PONs for the 5G Wireless Systems," in *IEEE Photonics Journal*, vol. 7, no. 6, pp. 1-6, Dec. 2015.
- Jin Seek Choi, Hyun Pil Kim, Min Soo Kim, Min Seop Shin, Jung Mo Park and Eunhong Park, "An experimental implementation of MPLS-TP controlled Ethernet transport network for mobile backhaul," *Digest of the 9th International Conference on Optical Internet (COIN 2010)*, Jeju, 2010, pp. 1-3.
- K. K. Nguyen and M. Cheriet, "Enabling infrastructure as a service (IaaS) on IP networks: from distributed to virtualized control plane," in *IEEE Communications Magazine*, vol. 51, no. 1, pp. 136-144, January 2013.
- Kuri, Josué, et al. "Routing and wavelength assignment of scheduled lightpath demands." *IEEE Journal on Selected Areas in Communications* 21.8 (2003): 1231-1240.

- L. Liu, W. Peng, R. Casellas, T. Tsuritani, I. Morita, R. Martínez, R. Muñoz, and S. Yoo, "Design and performance evaluation of an OpenFlow-based control plane for software-defined elastic optical networks with direct-detection optical OFDM (DDO-OFDM) transmission," *Opt. Express* 22, 30-40 (2014).
- L. Peterson et al., "Central office re-architected as a data center", in *IEEE Communications Magazine*, vol. 54, no. 10, pp. 96-101, October 2016.
- Light Reading Magazine, April 2015
- M. A. Khan, S. Leng, Wang Xiang and Kun Yang, "Architecture of heterogeneous wireless access networks: A short survey," *TENCON 2015 - 2015 IEEE Region 10 Conference*, Macao, 2015, pp. 1-6.
- M. Agiwal, A. Roy and N. Saxena, "Next Generation 5G Wireless Networks: A Comprehensive Survey," in *IEEE Communications Surveys and Tutorials*, vol. 18, no.3, pp. 1617-1655, third quarter 2016.
- M. Bertolini, O. Rocher, A. Bisson, P. Pecci and G. Bellotti, "Benefits of OTN switching introduction in 100Gb/s optical transport networks," *OFC/NFOEC*, Los Angeles, CA, 2012, pp. 1-3.
- M. Bertolini, O. Rocher, A. Bisson, P. Pecci and G. Bellotti, "Multi-rate vs. OTN: Comparing approaches to build scalable, cost-effective 100Gb/s networks," *2012 38<sup>th</sup> European Conference and Exhibition on Optical Communications*, Amsterdam, 2012, pp. 1-3.
- M. Chamania and A. Jukan, "A survey of inter-domain peering and provisioning solutions for the next generation optical networks," in *IEEE Communications Surveys and Tutorials*, vol. 11, no. 1, pp. 33-51, First Quarter 2009.
- M. Donovan and K. Conroy, "Enabling the cost-effective implementation of Metro-Ethernet for Optical-Based Metro and Long-Haul Transport Networks," *OFC/NFOEC 2008 - 2008 Conference on Optical Fiber Communication/National Fiber Optic Engineers Conference*, San Diego, CA, 2008, pp. 1-5.
- M. Fiorani et al., "Challenges for 5G transport networks," *2014 IEEE International Conference on Advanced Networks and Telecommunications Systems (ANTS)*, New Delhi, 2014, pp. 1-6.
- M. Fiorani et al., "Challenges for 5G transport networks," *2014 IEEE International Conference on Advanced Networks and Telecommunications Systems (ANTS)*, New Delhi, 2014, pp. 1-6.
- M. Jaber, M. A. Imran, R. Tafazolli and A. Tukmanov, "5G Backhaul Challenges and Emerging Research Directions: A Survey," in *IEEE Access*, vol. 4, no., pp. 1743-1766, 2016.

- M. Jaber, M. A. Imran, R. Tafazolli and A. Tukmanov, "5G Backhaul Challenges and Emerging Research Directions: A Survey," in *IEEE Access*, vol. 4, pp. 1743-1766, 2016.
- M. Mahloo, P. Monti, J. Chen and L. Wosinska, "Cost modeling of backhaul for mobile networks," 2014 *IEEE International Conference on Communications Workshops (ICC)*, Sydney, NSW, 2014, pp. 397-402.
- M. Mahloo, P. Monti, J. Chen and L. Wosinska, "Cost modeling of backhaul for mobile networks," 2014 *IEEE International Conference on Communications Workshops (ICC)*, Sydney, NSW, 2014, pp. 397-402.
- M. Murakami and Y. Koike, "Highly Reliable and Large-Capacity Packet Transport Networks: Technologies, Perspectives, and Standardization," in *Journal of Lightwave Technology*, vol. 32, no. 4, pp. 805-816, Feb.15, 2014.
- M. Nowell, "Interworking of IP and OTN networks - making IP over OTN a reality," 2009 *Conference on Optical Fiber Communication - includes post deadline papers*, San Diego, CA, 2009, pp. 1-3.
- M. R. Sama, S. Beker, W. Kiess and S. Thakolsri, "Service-Based Slice Selection Function for 5G," 2016 *IEEE Global Communications Conference (GLOBECOM)*, 2016, pp. 1-6.
- M. S. Zefreh, A. Tizghadam, A. Leon-Garcia, H.Elbiaze, W. Miron, "CapEx Optimization in Multi-Chassis Multi-Rate IP/Optical Networks", *International Conference on Computing, Networking and Communications (ICNC)*, 2016.
- M. S. Zefreh, A. Tizghadam, A. Leon-Garcia, H.Elbiaze, W. Miron, "CapEx Optimization in Multi-Chassis Multi-Rate IP/Optical Networks", *IEEE TRANSACTIONS ON WIRELESS COMMUNICATIONS*, VOL. 13, NO. 9, SEPTEMBER 2014.
- M. Savić, I. Papp, I. Rešetar, D. Majstorović and D. Spasojević, "Implementation of server push mechanism based on TR-069 and TR-111 protocols for network device management," 2013 *21st Telecommunications Forum Telfor (TELFOR)*, Belgrade, 2013, pp. 361-364.
- M. Stusek et al., "Remote management of intelligent devices: Using TR-069 protocol in IoT," 2016 *39th International Conference on Telecommunications and Signal Processing (TSP)*, Vienna, 2016, pp. 74-78.
- MEF Forum 2012, Implementation Agreement MEF 22.1. Mobile protection Phase 2, 2012.
- MEF Forum 2012, Implementation Agreement MEF 23.1. Carrier Ethernet Class of Service Phase 2, 2012.

- N. Bitar, "Transport network evolution: From TDM to packet," 2011 Optical Fiber Communication Conference and Exposition and the National Fiber Optic Engineers Conference, Los Angeles, CA, 2011, pp. 1-3.
- N. Chen, B. Rong, X. Zhang and M. Kadoch, "Scalable and Flexible Massive MIMO Precoding for 5G H-CRAN", IEEE Wireless Communications, vol. 24, no. 1, pp. 46-52, February 2017.
- N. Haddaji, A. Bayati, K. Nguyen, and M. Cheriet, "Backhauling-as-a-Service (BHaaS) for 5G Optical Sliced Networks: An Optimized TCO Approach", IEEE OSA Journal of Lightwave Technology, July 2018.
- N. Haddaji, K. Nguyen and M. Cheriet, "Towards End-to-End Integrated Optical Packet Network: Empirical Analysis," Elsevier, Optical Switching and Networking, June 2017.
- N. Honda, D. Iida, H. Izumita and Y. Azuma, "In-Service Line Monitoring System in PONs Using 1650-nm Brillouin OTDR and Fibers with Individually Assigned BFSs," in Journal of Lightwave Technology, vol. 27, no. 20, pp. 4575-4582, Oct.15, 2009.
- N. Kitsuwon, S. McGettrick, F. Slyne, D. B. Payne and M. Ruffini, "Independent transient plane design for protection in OpenFlow-based networks," in IEEE/OSA Journal of Optical Communications and Networking, vol. 7, no. 4, pp. 264-275, April 2015.
- N. Kolydakis and I. Tomkos, "A techno-economic evaluation of different strategies for front-/back-hauling of mobile traffic: Wireless versus fiber-based solutions," 2014 16th International Conference on Transparent Optical Networks (ICTON), 2014, pp. 1-4.
- N. Wang, E. Hossain and V. K. Bhargava, "Backhauling 5G small cells: A radio resource management perspective," in IEEE Wireless Communications, vol. 22, no. 5, pp. 41-49, October 2015.
- Nishtha and M. Sood, "A survey on issues of concern in Software Defined Networks," 2015 Third International Conference on Image Information Processing (ICIIP), Wagnaghat, 2015, pp. 295-300.
- O. Stein and N. Sudermann-Merx, "The noncooperative transportation problem and linear generalized Nash games", Elsevier, European Journal of Operational Research, 2018.
- O. Yoshida, T. Nishi and G. Zhang, "Analysis of quantity discounts for multi-period production planning for single supplier and retailer under uncertain demands," 2014 IEEE International Conference on Industrial Engineering and Engineering Management, Bandar Sunway, 2014, pp. 882-886.
- Ould-Brahim, Hamid, et al. "Service Requirements for Optical VPNs." IETF, draft-ouldbrahim-ovpn-requirements-00.txt, 2003.



- P. Gunawardana and M. V. Shastri, "Optimized IP-MPLS transport for optical networks with next gen switching," 2011 Optical Fiber Communication Conference and Exposition and the National Fiber Optic Engineers Conference, Los Angeles, CA, 2011, pp. 1-3.
- P. Iovanna, F. Ubaldi, F. Di Michele, J. P. Fernandez-Palacios Gimenez and V. Lopez, "E2E traffic engineering routing for transport SDN," OFC 2014, San Francisco, CA, 2014, pp. 1-3.
- P. K. Agyapong, M. Iwamura, D. Staehle, W. Kiess and A. Benjebbour, "Design considerations for a 5G network architecture," in IEEE Communications Magazine, vol. 52, no. 11, pp. 65-75, Nov. 2014.
- P. K. Dalela, A. Yadav, A. Yadav, N. K. Kushwaha, P. Bansal and V. Tyagi, "Geo-Intelligence based fiber fault localization system for rural India," 2015 International Conference on Industrial Instrumentation and Control (ICIC), Pune, 2015, pp. 697-702.
- P. S. Khodashenas et al., "5G network challenges and realization insights," 18th International Conference on Transparent Optical Networks (ICTON), 2016, pp. 1-4.
- Q. Zhang, X. Wang, P. Palacharla, M. Sekiya and D. Bihon, "Shared mesh restoration for OTN/WDM networks using CDC-ROADMs," 2012 38th European Conference and Exhibition on Optical Communications, Amsterdam, 2012, pp. 1-3.
- R. Casellas, R. Martínez, R. Muñoz, L. Liu, T. Tsuritani and I. Morita, "Interlayer Traffic Engineering with hierarchical-PCE in MPLS-TP over wavelength switched optical networks," 2012 38th European Conference and Exhibition on Optical Communications, Amsterdam, 2012, pp. 1-3.
- R. Martinez, R. Casellas and R. Muñoz, "Experimental assessment of dynamic integrated restoration in GMPLS multi-layer (MPLS-TP/WSON) networks," 2012 38<sup>th</sup> European Conference and Exhibition on Optical Communications, Amsterdam, 2012, pp. 1-3.
- R. Martínez, R. Casellas and R. Muñoz, "Lab trial of a GMPLS controlled MPLS-TP packet transport network with source/PCE path computations," 2011 37th European Conference and Exhibition on Optical Communication, Geneva, 2011, pp. 1-3.
- R. Martínez, R. Casellas, R. Muñoz and R. Vilalta, "Requirements and enhancements for the evolution of the GMPLS control plane of the ADRENALINE testbed to support multi-layer (MPLS-TP/WSON) capabilities," 2011 13th International Conference on Transparent Optical Networks, Stockholm, 2011, pp. 1-4.
- R. Muñoz, R. Casellas, R. Martínez and R. Vilalta, "Experimental demonstration of a hybrid operated MPLS-TP transport network for dynamic Ethernet service provisioning and restoration," OFC/NFOEC, Los Angeles, CA, 2012, pp. 1-3.



- R. Muñoz, R. Casellas, R. Martínez and R. Vilalta, "PCE: What is It, How Does It Work and What are Its Limitations?", in *Journal of Lightwave Technology*, vol. 32, no. 4, pp. 528-543, Feb.15, 2014.
- R. Veisllari, S. Bjornstad, J. P. Braute, K. Bozorgebrahimi and C. Raffaelli, "Field-trial demonstration of cost efficient sub-wavelength service through integrated packet/circuit hybrid network [invited]," in *IEEE/OSA Journal of Optical Communications and Networking*, vol. 7, no. 3, pp. A379-A387, March 2015.
- S. G. Polito, S. Zaghoul, M. Chamania and A. Jukan, "Inter-Domain Path Provisioning with Security Features: Architecture and Signaling Performance," in *IEEE Transactions on Network and Service Management*, vol. 8, no. 3, pp. 219-233, September 2011.
- S. J. Trowbridge, "Ethernet and OTN - 400G and beyond," 2015 Optical Fiber Communications Conference and Exhibition (OFC), Los Angeles, CA, 2015, pp. 1-18.
- S. K. Das, S. K. Naik and S. K. Patra, "Fiber material dependent QoS analysis and OVPN connection setup over WDM/DWDM network," *TENCON 2011, IEEE Region 10 Conference, Bali, 2011*, pp. 521-525.
- S. M. Yu and S.-L. Kim, "Game-Theoretic Understanding of Price Dynamics in Mobile Communication Services", *IEEE TRANSACTIONS ON WIRELESS COMMUNICATIONS*, VOL. 13, NO. 9, SEPTEMBER 2014.
- S. Meier and H. Weibel, "IEEE 1588 applied in the environment of high availability LANs," 2007 IEEE International Symposium on Precision Clock Synchronization for Measurement, Control and Communication, Vienna, 2007, pp. 100-104.
- S. Phelps and M. Wooldridge, "Game Theory and Evolution", *IEEE Intelligent Systems*, December 2013.
- S. Roy, O. Turkcu, S. Hand and S. Melle, "Variation of OTN switching benefits in real-world networks based on network and traffic connectivity," *OFC 2014, San Francisco, CA, 2014*, pp. 1-3.
- S. Scott-Hayward, S. Natarajan and S. Sezer, "A Survey of Security in Software Defined Networks," in *IEEE Communications Surveys and Tutorials*, vol. 18, no. 1, pp. 623-654, Firstquarter 2016.
- S. Sun, M. Kadoch, L. Gong and B. Rong, "Integrating network function virtualization with SDR and SDN for 4G/5G networks," in *IEEE Network*, vol. 29, no. 3, pp. 54-59, May-June 2015.
- S. Verbrugge et al., "FTTH deployment and its impact on network maintenance and repair costs," 2008 10th Anniversary International Conference on Transparent Optical Networks, Athens, 2008, pp. 2-5.

- S. Verbrugge et al., "FTTH deployment and its impact on network maintenance and repair costs," 2008 10th Anniversary International Conference on Transparent Optical Networks, Athens, 2008, pp. 2-5.
- S. Yin, S. Huang, X. Li, J. Zhang, M. Zhang and W. Gu, "Integrated-layer routing and resources assignment optimization in mixed-line-rate IP over OTN networks," 2012 Asia Communications and Photonics Conference (ACP), Guangzhou, 2012, pp. 1-3.
- S. Zhang, C. Martel and B. Mukherjee, "Dynamic Traffic Grooming in Elastic Optical Networks," in IEEE Journal on Selected Areas in Communications, vol. 31, no. 1, pp. 4-12, January 2013.
- T. Bakhshi and B. Ghita, "Traffic Profiling: Evaluating Stability in Multi-device User Environments," 2016 30th International Conference on Advanced Information Networking and Applications Workshops (WAINA), 2016, pp. 731-736.
- T. H. Wang, Y. C. Chen, C. M. Hsu, K. S. Hsu and H. C. Young, "Auto scaling of containerized ACSs for CPE management," 2016 18th Asia-Pacific Network Operations and Management Symposium (APNOMS), Kanazawa, 2016, pp. 1-4.
- T. M. Knoll, "Life-cycle cost modelling for NFV/SDN based mobile networks," 2015 Conference of Telecommunication, Media and Internet Techno-Economics (CTTE), 2015, pp. 1-8.
- T. O. Olwal, K. Djouani and A. M. Kurien, "A Survey of Resource Management Toward 5G Radio Access Networks," in IEEE Communications Surveys and Tutorials, vol. 18, no. 3, pp. 1656-1686, third quarter 2016.
- V. Eramo, M. Listanti, R. Sabella and F. Testa, "Definition and performance evaluation of a low-cost/high-capacity scalable integrated OTN/WDM switch," in IEEE/OSA Journal of Optical Communications and Networking, vol. 4, no. 12, pp. 1033-1045, Dec. 2012.
- V. Eramo, M. Listanti, R. Sabella and F. Testa, "Integrated OTN/WDM switching architecture equipped with the minimum number of OTN switches," in IEEE/OSA Journal of Optical Communications and Networking, vol. 6, no. 2, pp. 138-151, Feb. 2014.
- V. Hutcheon, "OTN to enable flexible networks," 2011 Optical Fiber Communication Conference and Exposition and the National Fiber Optic Engineers Conference, Los Angeles, CA, 2011, pp. 1-3.
- W. I. Way, P. N. Ji and A. N. Patel, "Contention resolution within colorless and directionless ROADMs," 2013 Optical Fiber Communication Conference and Exposition and the National Fiber Optic Engineers Conference (OFC/NFOEC), Anaheim, CA, 2013, pp. 1-3.

- W. I. Way, P. N. Ji and A. N. Patel, "Wavelength contention-free via optical bypass within a colorless and directionless ROADM [invited]," in *IEEE/OSA Journal of Optical Communications and Networking*, vol. 5, no. 10, pp. A220-A229, Oct. 2013.
- W. L. Chin and S. G. Chen, "IEEE 1588 clock synchronization using dual slave clocks in a slave," in *IEEE Communications Letters*, vol. 13, no. 6, pp. 456-458, June 2009.
- W. Lu, Z. Zhu and B. Mukherjee, "On Hybrid IR and AR Service Provisioning in Elastic Optical Networks," in *Journal of Lightwave Technology*, vol. 33, no. 22, pp. 4659-4670, Nov.15, 15 2015.
- W. Wang, Q. Qi, X. Gong, Y. Hu and X. Que, "Autonomic QoS management mechanism in Software Defined Network," in *China Communications*, vol. 11, no. 7, pp. 13-23, July 2014.
- White paper, "Central Office Re-architected as a Datacenter (CORD)", <https://opencord.org/>, March 14, 2016.
- X. Chen, B. Zhao; S. Ma, C. Chen, D. Hu, W. Zhou, Z. Zhu, "Leveraging master-slave OpenFlow controller arrangement to improve control plane resiliency in SD-EONs," *OpEx 2015*.
- X. Chen, M. Tornatore, S. Zhu, F. Ji, W. Zhou, C. Chen, D. Hu, L. Jiang, and Z. Zhu, "Flexible Availability-Aware Differentiated Protection in Software-Defined Elastic Optical Networks," in *Journal of Lightwave Technology*, vol. 33, no. 18, pp. 3872-3882, Sept.15, 15 2015.
- X. Chen, Z. Zhu, L. Sun, J. Yin, S. Zhu, A. Castro, and S. J. B. Yoo, "Incentive-Driven Bidding Strategy for Brokers to Compete for Service Provisioning Tasks in Multi-Domain SD-EONs," in *Journal of Lightwave Technology*, vol. 34, no. 16, pp. 3867-3876, Aug.15, 15 2016.
- X. Zhou, R. Li, T. Chen and H. Zhang, "Network slicing as a service: enabling enterprises' own software-defined cellular networks," *IEEE Communications Magazine*, vol. 54, no. 7, pp. 146-153, July 2016.
- Y. Li and M. Chen, "Software-Defined Network Function Virtualization: A Survey," in *IEEE Access*, vol. 3, no. , pp. 2542-2553, 2015.
- Y. Miyamoto, A. Sano and T. Kobayashi, "The challenge for the next generation OTN based on 400Gbps and beyond," *OFC/NFOEC*, Los Angeles, CA, 2012, pp. 1-3.
- Z. Zhu, C. Chen, X. Chen, S. Ma, L. Liu, X. Feng, and S. Yoo, "Demonstration of Cooperative Resource Allocation in an OpenFlow-Controlled Multidomain and Multinational SD-EON Testbed," *J. Lightwave Technol.* 33, 1508-1514 (2015).

Z. Zhu, W. Lu, L. Zhang and N. Ansari, "Dynamic Service Provisioning in Elastic Optical Networks With Hybrid Single-/Multi-Path Routing," in *Journal of Lightwave Technology*, vol. 31, no. 1, pp. 15-22, Jan.1, 2013.